



TDFN



SO8

## KMT32B

### Magnetic Angle Sensor

#### SPECIFICATIONS

- AMR Sensor with 180° period
- high accuracy
- high resolution
- for the use at moderate field strengths
- tiny TDFN package
- ROHS & REACH compliant

The KMT32B is a magnetic field sensor based on the anisotropic magneto resistance effect, i.e. it is sensing the **magnetic field direction** independently on the magnetic field strength for applied field strengths  $H > 25$  kA/m. The sensor contains two parallel supplied Wheatstone bridges, which enclose a sensitive angle of 45 degrees.

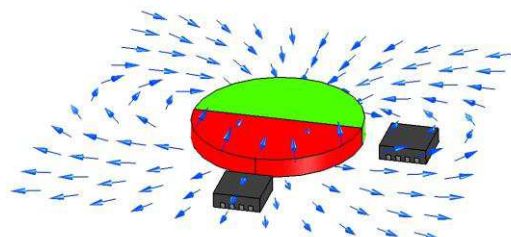
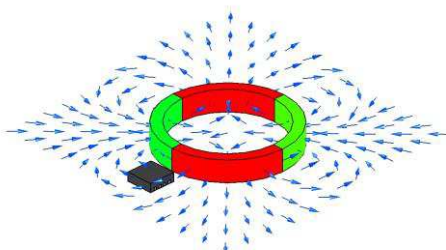
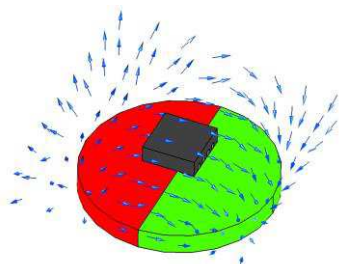

#### FEATURES

- Contactless angular position, ideal for harsh environments
- Design optimized for linearity
- High accuracy
- Low cost, low power
- Self diagnosis feature
- Attractive SMD packages
- User has complete control over signal evaluation
- Extended operating temperature range (-40 °C to +150 °C, +160°C on request)
- REACH & RoHS compliant (lead free)

A rotating magnetic field in the surface parallel to the chip (x-y plane) will therefore deliver two independent sinusoidal output signals, one following a  $\cos(2\alpha)$  and the second following a  $\sin(2\alpha)$  function,  $\alpha$  being the angle between sensor and field direction (see Figure 2).

The KMT32B magnetic field sensor is suited for high precision angle measurement applications at a regular field strength of  $H_0 \geq 25$  kA/m (generated for example with magnet 67.044 from Magnetfabrik Bonn at a distance of 5.2 mm at room temperature). With reduced accuracy, the sensor KMT32B may be used with a field strength of  $H_0 \geq 14$  kA/m (at room temperature; be aware of the influence of the earth magnetic field!). Most magnets show a decreasing field strength with temperature while the magnetic field direction is unchanged.



## APPLICATIONS

- Absolute and incremental angle measurement
- Automotive (steering angle, torque)
- Robotics
- Camera positioning
- Potentiometer replacement
- Position measurement in medical applications
- Motor motion control

## CHARACTERISTIC VALUES

Parameter	Symbol	Condition	Min	Typ	Max	Unit
<b>A. Operating Limits</b>						
Max. supply voltage	$V_{CC,max}$				<b>10</b>	V
Max. current (single bridge)	$I_{CC,max}$				<b>4</b>	mA
Operating temperature	$T_{op}$		<b>-40</b>		<b>+150</b>	°C
Storage temperature	$T_{st}$		<b>-40</b>		<b>+150</b>	°C
<b>B. Sensor Specifications (T=25 °C)</b>						
Supply voltage	$V_{CC}$			<b>5</b>		V
Resistance (single bridge)	$R_b$		<b>2400</b>	<b>3000</b>	<b>3600</b>	$\Omega$
Output signal amplitude	$V_{PEAK}$	Condition A, B	<b>9</b>	<b>11</b>	<b>13</b>	mV/V
Offset voltage	$V_{OFF}$	Condition A, B	<b>-1</b>	<b>0</b>	<b>+1</b>	mV/V
Angular inaccuracy	$\Delta\alpha$	Condition A, B		<b>0.05</b>	<b>0.2</b>	deg
Angular hysteresis	$\Delta\alpha_H$	Condition A, B			<b>0.1</b>	deg
<b>C. Sensor Specifications</b>						
TC of amplitude	TCSV	Condition A, C		<b>-0.35</b>		%/K
TC of resistance	TCBR	Condition A, C		<b>+0.35</b>		%/K
TC of offset	TCVoff	Condition A, C	<b>-4</b>	<b>0</b>	<b>+4</b>	$\mu V/V/K$

Stress above one or more of the limiting values may cause permanent damage to the device. Exposure to limiting values for extended periods may affect device reliability.

## MEASUREMENT CONDITIONS

Parameter	Symbol	Unit	Condition
<b>Condition A: Set Up Conditions</b>			
Ambient temperature	T	°C	T = 25 °C (unless otherwise noted)
Supply voltage	$V_{CC}$	V	$V_{CC} = 5 V$
Applied magnetic field	H	kA/m	H = 25 kA/m

Condition B: Sensor Specifications (360° turn , Vo <sub>max</sub> >0, Vo <sub>min</sub> <0)			
Output signal amplitude	V <sub>PEAK</sub>	mV/V	$V_{PEAK} = (V_{Omax} - V_{Omin})/2/V_{CC}$
Offset voltage	V <sub>OFF</sub>	mV/V	$V_{OFF} = (V_{Omax} + V_{Omin})/2/V_{CC}$
Angular inaccuracy	Δα	deg	Δα = MAX α <sub>0</sub> -α ; max. angular difference between actual field angle α <sub>0</sub> and measured angle α due to deviations from ideal sinusoidal characteristics, calculated from the third and fifth harmonics of the Fourier spectrum; offset voltage error contributions not included
Angular hysteresis	ΔαH	deg	ΔαH =  α <sub>left turn</sub> - α <sub>right turn</sub>   angular difference between left and right turn

## MEASUREMENT CONDITIONS

Parameter	Symbol	Unit	Condition
Condition C: Sensor Specifications (-25°C, +125°C)			
Ambient temperatures	T	°C	T <sub>1</sub> = -25 °C, T <sub>0</sub> = +25 °C, T <sub>2</sub> = +125 °C
TC of amplitude	TCSV	%/K	$TCV = \frac{1}{(T_2 - T_1)} \cdot \frac{\frac{\Delta Vn}{V_{CC}}(T_2) - \frac{\Delta Vn}{V_{CC}}(T_1)}{\frac{\Delta Vn}{V_{CC}}(T_1)} \cdot 100\%$
TC of resistance	TCBR	%/K	$TCR = \frac{1}{(T_2 - T_1)} \cdot \frac{R(T_2) - R(T_1)}{R(T_1)} \cdot 100\%$
TC of offset	TCVoff	(μV/V)/K	$TCV_{off} = \frac{V_{off}(T_2) - V_{off}(T_1)}{(T_2 - T_1)}$

## BLOCK DIAGRAM

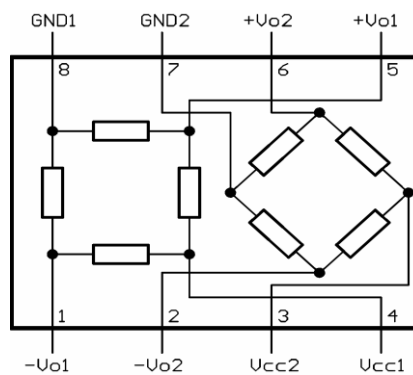
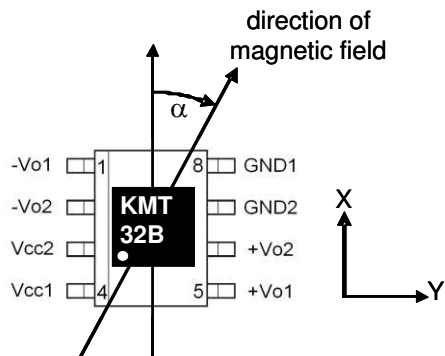
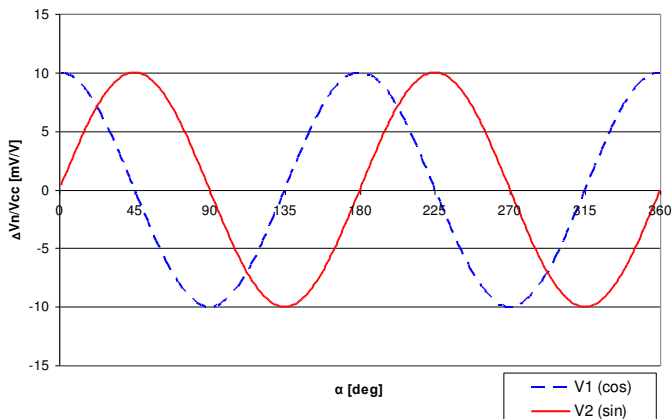

Figure 1: Circuit Diagram

## TYPICAL PERFORMANCE CURVES



**Figure 2:** Characteristic curves for KMT32B (SO8, TDFN)

## PACKAGES

### SO8

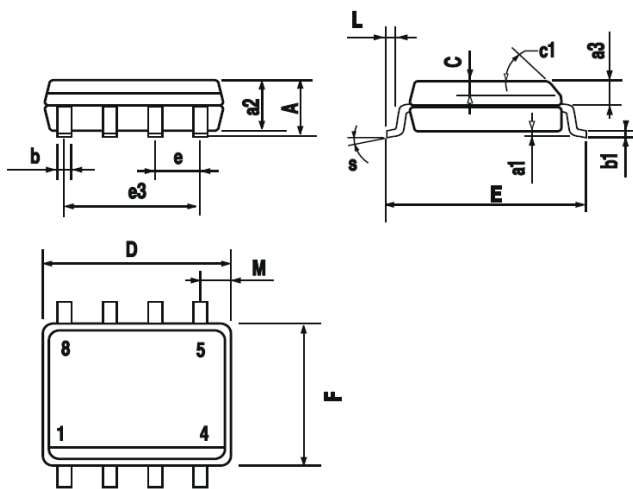

DIM.	mm			inch		
	MIN.	TYP.	MAX.	MIN.	TYP.	MAX.
A			1.75			0.069
a1	0.1		0.25	0.004		0.010
a2			1.65			0.065
a3	0.65		0.85	0.026		0.033
b	0.35		0.48	0.014		0.019
b1	0.19		0.25	0.007		0.010
C	0.25		0.5	0.010		0.020
c1	45° (typ.)					
D (1)	4.8		5.0	0.189		0.197
E	5.8		6.2	0.228		0.244
e		1.27			0.050	
e3		3.81			0.150	
F (1)	3.8		4.0	0.15		0.157
L	0.4		1.27	0.016		0.050
M			0.6			0.024
S	8° (max.)					

**TDFN 2.5\*2.5**

unit: mm

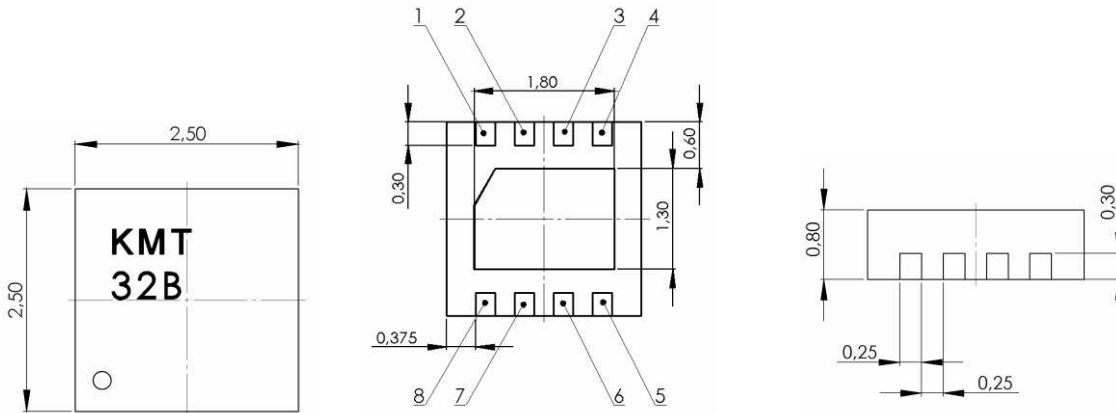
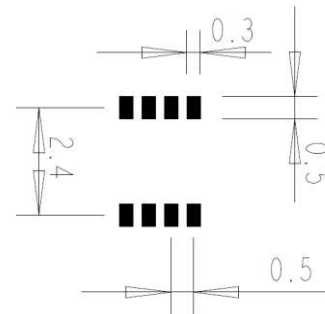
**RECOMMENDED SOLDER PAD LAYOUT FOR TDFN**

**PIN ASSIGNMENT (SO8, TDFN)**

Pin (SO8)	Pin (TDFN)	Symbol	Function
1	7	$-V_{o1}$	negative output bridge 1
2	8	$-V_{o2}$	negative output bridge 2
3	1	$V_{cc2}$	positive supply voltage bridge 2
4	2	$V_{cc1}$	positive supply voltage bridge 1
5	3	$+V_{o1}$	positive output bridge 1
6	4	$+V_{o2}$	positive output bridge 2
7	5	$GND_2$	negative supply voltage bridge 2
8	6	$GND_1$	negative supply voltage bridge 1

**SOLDER PROFILE**

Recommended solder reflow process according to IPC/JEDEC J-STD-020D (Pb-Free Process)

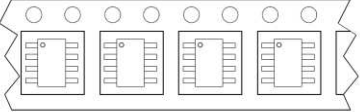

### TAPE AND REEL PACKAGING INFORMATION

Description	Reel size	Units/reel	Pin 1 orientation	Note
KMT32B/TD	7"	3,000	Top-right of sprocket hole side	
KMT32B/SO	13"	2,500	Top-left of sprocket hole side	

### ORDERING CODE

Device	Package	MOQ	Part Number
KMT 32B/SO	SO-8	1 reel	G-MRCO-015
KMT 32B/TD	TDFN 2.5 x 2.5	1 reel	G-MRCO-016

### ORDERING INFORMATION