

KMXP SERIES

Anisotropic Magneto-Resistive (AMR) Linear Position Sensors

Position sensors play an increasingly important role in many industrial, robotic and medical applications. Advanced applications in harsh environments need sensors that perform well, even when exposed to oil, dirt and dust.

The TE Connectivity KMXP position sensor is the right choice to meet those needs thanks to its Magneto Resistive technology and available form factors. The KMXP sensor provides greater precision than commonly used Hall sensors and is designed to provide reliable and accurate measurements in harsh environments including high temperatures.

The sensor measuring principle is based on the anisotropic magneto resistance effect (AMR effect).

The sensors are offered in two different DFN packages for multiple orientation options. These packages can be easily integrated to almost any automated assembly process.

FEATURES

- High Resolution and high precision – Magneto Resistive (MR) sensor with contactless measurement which provides accuracy of 10-50 μm in ranges between 1 – 5 mm.
- Easy Assembly – DFN package ideal for any PCB assembly processes.
- Tape & Reel packaging for easy integration
- Design Freedom – Perpendicular or flat soldering versions and a small sensor wall thickness for large application air gaps.
- Superior Performance – Up to 150°C, EMC proof in any dirty environment and insensitive to dirt, oil or dust.

APPLICATIONS

Contactless linear or angular position measurement in applications like:

- Industrial machinery like sawing or drilling equipment
- Medical high precision mechanical controls like bed control, advanced prosthesis steering, precision catheters, X-ray equipment, or syringe pumps
- Robotics in industrial automation

MEASUREMENT PRINCIPLE

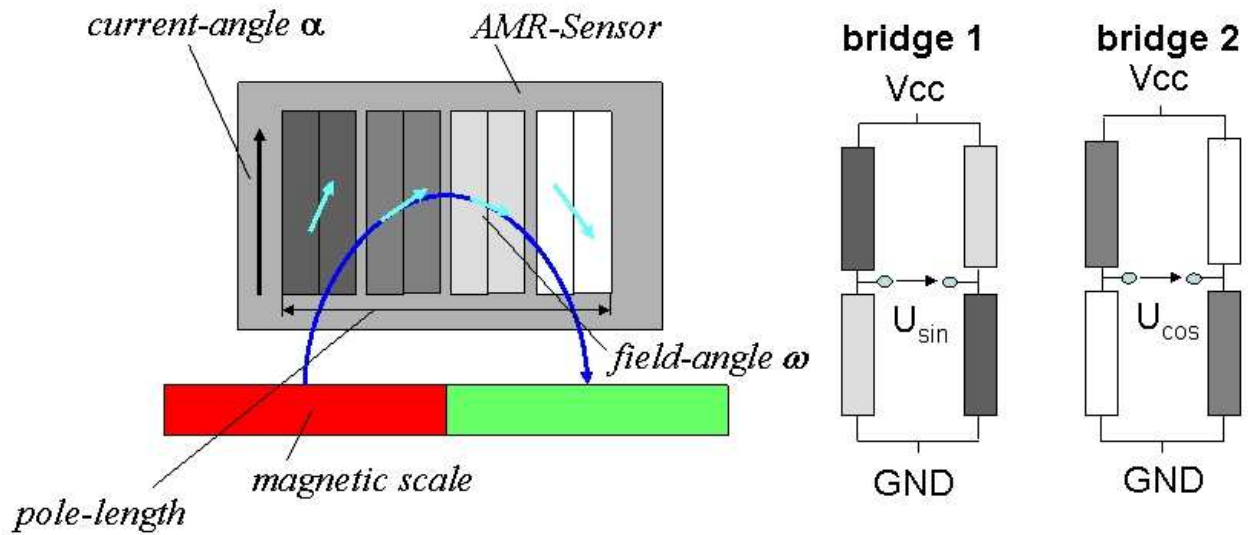


Figure 1: principle function of the sensor

The KMP sensors consist of two magneto resistive Wheatstone bridges, whose resistors are placed in a such way that the characteristic magnetic field distribution of a magnetic scale with matching pole pitch produces a sine and a cosine signal output when the sensor is moved along the scale.

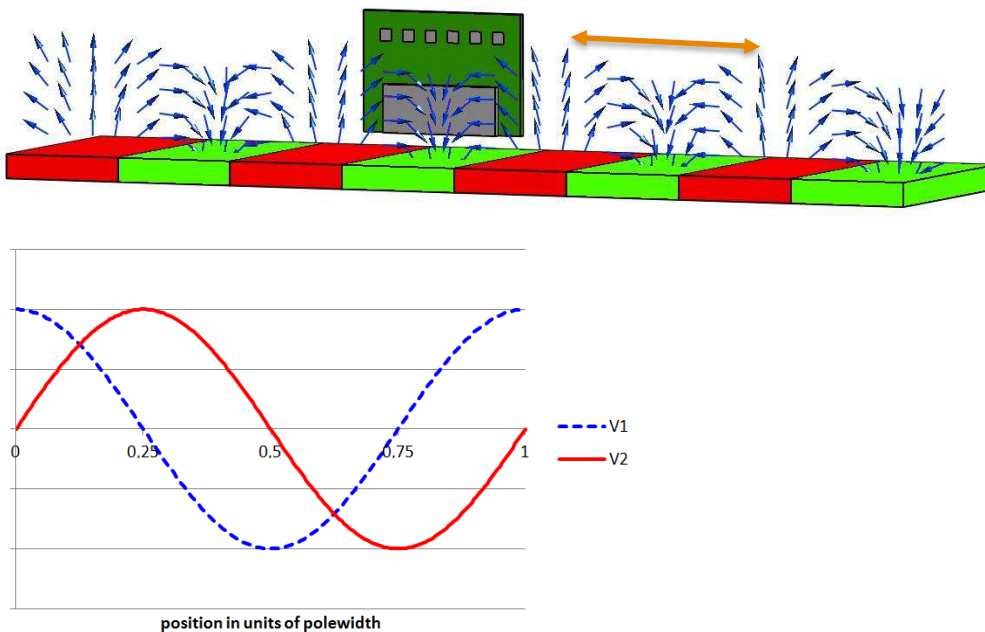


Figure 2: typical application of a PCB mounted KMP sensor moving relative to a magnetic pole and the corresponding output signal voltage depending on sensor position

PERFORMANCE SPECIFICATIONS

PARAMETER	SYMBOL	COND.	TYPE	MIN	TYP	MAX	UNIT
1. Operating Limits							
Max. supply voltage	$V_{cc,max}$		all			10	V
Max. current (both bridges)	$I_{cc,max}$		KMXP 1000 KMXP 2000/5000			5 10	mA
Operating temperature	T_{op}		all	-40		+150	°C
Storage temperature	T_{st}		all	-40		+150	°C
2. Sensor Specifications (T=25 °C)							
Supply voltage	V_{cc}		all		5		V
Pole pitch 1)	p		KMXP 1000 KMXP 2000 KMXP 5000		1000 2000 5000		μm
Air gap package front – magnetic scale 2)	D		KMXP 1000 KMXP 2000 KMXP 5000	0.1 0.2 0.5	0.4 0.8 2	0.8 1.8 4	mm
Resistance (both bridges)	R_b		KMXP 1000 KMXP 2000/5000	2000 1000	3000 1500	4000 2000	Ω
Output signal range	$\Delta V_n/V_{cc}$	A, B	all	18	22	26	mV/V
Offset voltage	$V_{n\ off}$	A, B	all	-1	0	+1	mV/V
3. Sensor Specifications							
TC of amplitude	TCSV	A, C	All		-0.35		%/K
TC of resistance	TGBR	A, C	All		+0.35		%/K
TC of offset	TCVoff	A, C	all	-4	0	+4	μV/V/K

$n = 1; 2$ (bridge number); Stress above one or more of the limiting values may cause permanent damage to the device. Exposure to limiting values for extended periods may affect device reliability.

1) Other pole pitches on request

2) Typical values for conventional magnetic scales. Air gap for maximum accuracy depends on the used scale.

MEASUREMENT SET UP CONDITIONS

PARAMETER	SYMBOL	UNIT	CONDITION
A. Set Up Conditions			
Ambient temperature	T	°C	T = 25 °C (unless otherwise noted)
Supply voltage	V _{cc}	V	V _{cc} = 5 V
Applied magnetic field	H	kA/m	H > 10 kA/m
B. Sensor Specifications (T=25 °C, 360° turn , H=25 kA/m , Vo_{max}>0, Vo_{min}<0)			
Output signal range	$\Delta V_n / V_{cc}$	mV/V	$\Delta V_n / V_{cc} = (V_{n \max} - V_{n \min}) / V_{cc}$
Signal offset	V _{off n}	mV/V	$V_{off n} = (V_{n \max} + V_{n \min}) / V_{cc}$

C. Sensor Specifications (T=-25°C, +125°C)			
Ambient temperatures	T	°C	T ₁ = -25 °C, T ₀ = +25 °C, T ₂ = +125 °C
TC of amplitude	TCSV	%/K	$TCV = \frac{1}{(T_2 - T_1)} \cdot \frac{\frac{\Delta V_n(T_2)}{V_{cc}} - \frac{\Delta V_n(T_1)}{V_{cc}}}{\frac{\Delta V_n(T_1)}{V_{cc}}} \cdot 100\%$
TC of resistance	TCBR	%/K	$TCR = \frac{1}{(T_2 - T_1)} \cdot \frac{R_n(T_2) - R_n(T_1)}{R_n(T_1)} \cdot 100\%$
TC of offset	TCV _{off}	μV/(VK)	$TCV_{off_n} = \frac{V_{off_n}(T_2) - V_{off_n}(T_1)}{(T_2 - T_1)}$

n = 1;2 (bridge number)

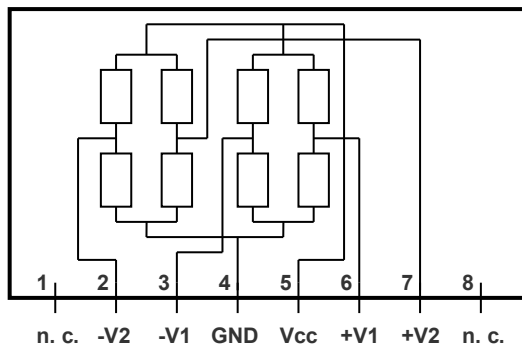
BLOCK DIAGRAM


Figure 3a: KMXP 1000/2000

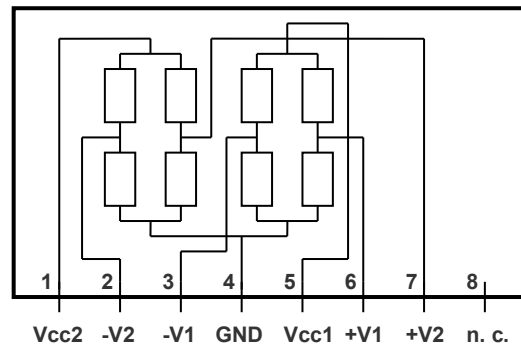


Figure 3b: KMXP 5000

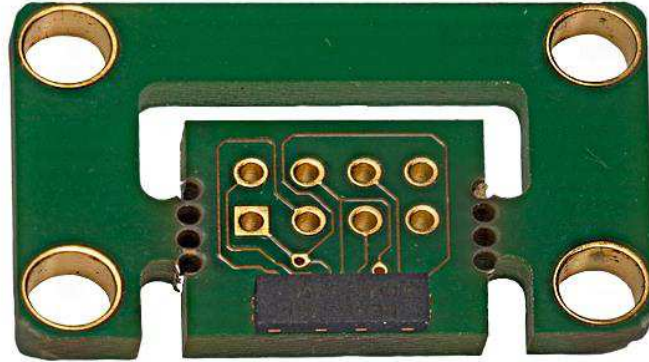
EXAMPLE OF PRINTED CIRCUIT BOARD ASSEMBLY


Figure 4: Flat mounted KMXP on a PCB

PIN ASSIGNMENT

The pin assignment is pin compatible for all KMXP types and allows a common PCB layout for all types:

Pin	1	2	3	4	5	6	7	8	9	10	11	12
KMXP5000	Vcc2	-V2	-V1	GND	Vcc1	+V1	+V2	N/C	N/C	N/C	N/C	N/C
KMXP2000	N/C	-V2	-V1	GND	Vcc	+V1	+V2	N/C	N/C	N/C	N/C	N/C
KMXP1000	N/C	-V2	-V1	GND	Vcc	+V1	+V2	N/C	N/C	N/C	N/C	N/C



PHYSICAL DIMENSIONS

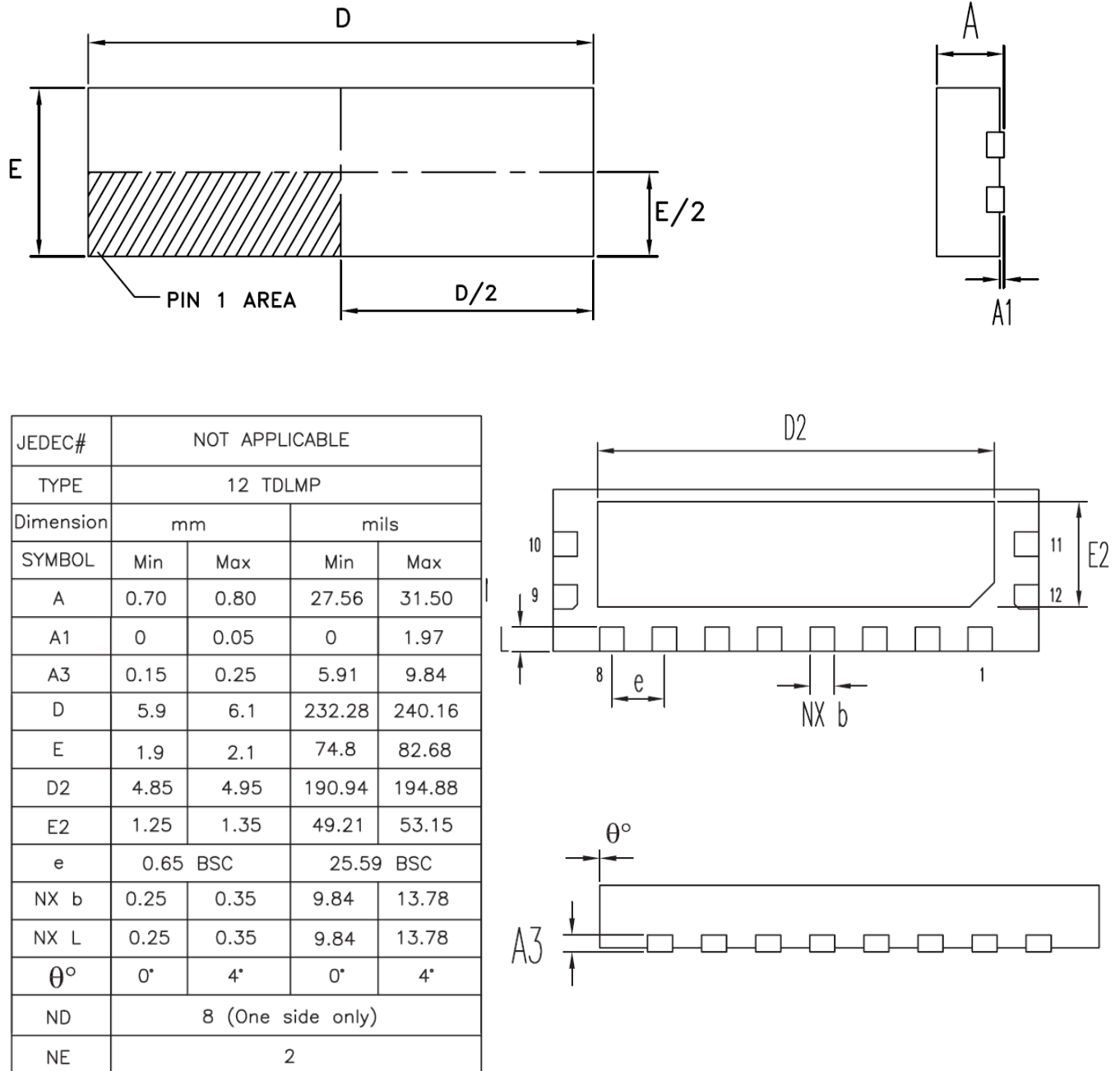


Fig. 5: Physical dimensions of sensor package

Reflow profile for this package according to IPC/JEDEC J-STD-020 Revision D.1 (March 2008).

APPLICATION EXAMPLE

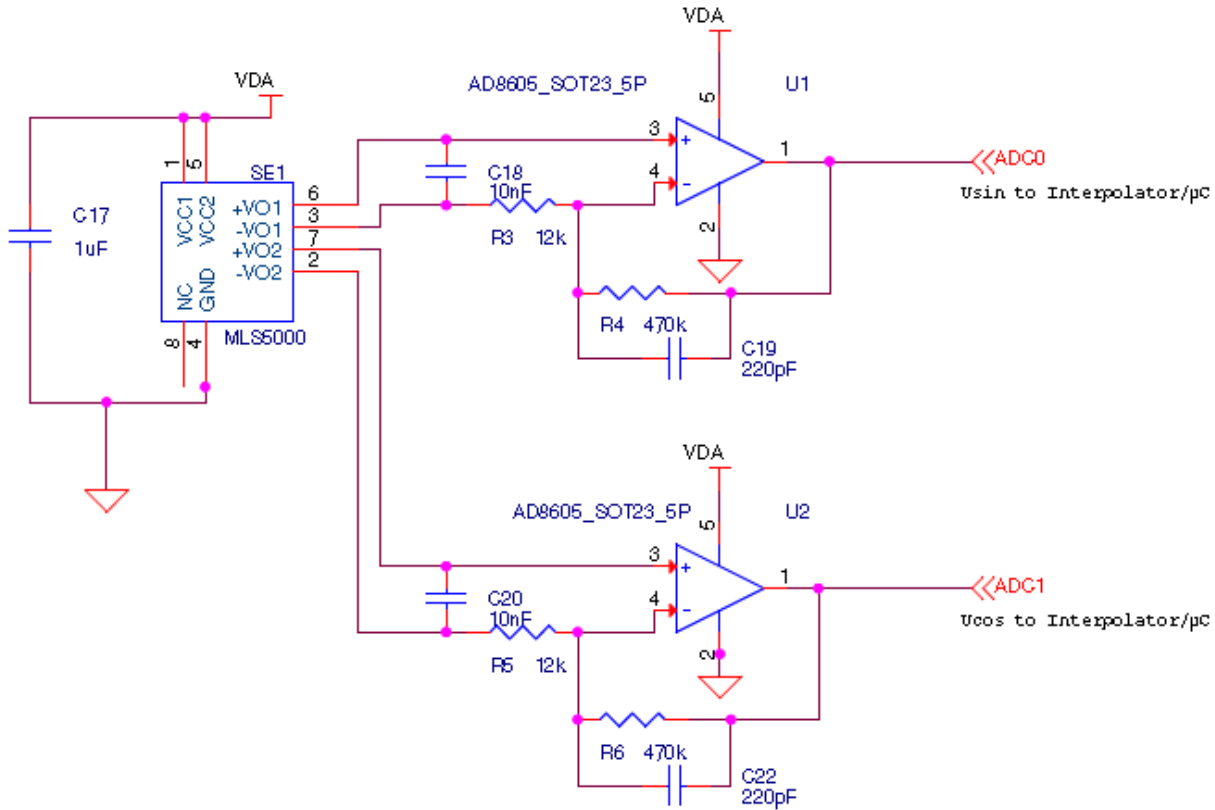


Fig. 6: Exemplary hardware configuration for the usage with a conventional microcontroller using an Analog Devices AD8605 amplifier for the preprocessing of the sensor signals.

ORDERING CODES

Part Number	Part Description	Pole Pitch
G-MRCO-051	KMXP1000 MLS 1MM PITCH DFN	1 mm
G-MRCO-050	KMXP2000 MLS 2MM PITCH DFN	2 mm
G-MRCO-052	KMXP5000 MLS 5MM PITCH DFN	5 mm
G-MRCO-055	KMXP1002 1MM PITCH VERTICAL	1 mm
G-MRCO-056	KMXP2002 2MM PITCH VERTICAL	2 mm
G-MRCO-057	KMXP5002 5MM PITCH VERTICAL	5 mm