

KMA36

Contactless Rotational and Linear Encoder

SPECIFICATIONS

- ◆ Contactless Absolute 360° (180°) angle measurement
- ◆ Incremental mode
- ◆ Linear mode
- ◆ Standard I2C Interface (100 kHz)
- ◆ Programmable resolution up to 13 bit (0.04 degree)
- ◆ Very low hysteresis
- ◆ High accuracy mode
- ◆ User programmable parameters
- ◆ Low power mode
- ◆ Sleep and automatic wake-up over I2C
- ◆ Programmable zero position
- ◆ Device address hardware configurable
- ◆ Small Pb-Free package (TSSOP20)
- ◆ RoHS compliant

The KMA36 is a highly reliable universal magnetic position sensor for precise rotational or linear measurement with a resolution up to 0.04 degree. These digital position sensors feature a system-on-chip technology that combines a magnetoresistive element along with analog to digital converter and signal processing in a standard small package. By using Anisotropic Magneto Resistive (AMR) technology, the KMA36 is able to determine accurately and non-contacting the magnetic angle of an external magnet over 360°, as well as the incremental position on a magnetic pole strip with 5 mm pole length. Its sleep and low power mode as well as automatic wake-up over I2C – make the KMA36 ideal for many battery applications. Position data can be transmitted using a PWM or digital two-wire (SDA, SCL) communication bus. Using the programmable parameters of this digital position sensor, the user can have access to a wide range of configuration to ensure the maximum of freedom and functionalities.

Used as both a linear position sensor or a rotary position sensor, these KMA36 magnetoresistive sensors designed by MEAS (Measurement Specialties) are insensitive to magnetic drift due to mechanical tolerances, changes in temperature or thermal stress. The maintenance-free operation and high bandwidth of this universal magnetic encoder makes it a good choice for dynamic applications in harsh environments.

KEY-FEATURES

Resolution	13 Bit / 0.04 degree
Operating power supply range of 3V to 5.5V	3.0 – 5.5V
Operating temperature	- 25 - +85 °C
Average current	10 – 30 mA
Sleep current	1.5 mA
Data Update rate	24 – 720 Hz
I²C Clockrate	Up to 100 kBit/s

APPLICATIONS

Industrial environment
 Harsh environment
 Handling machine
 Machine tools

Robotics
 Potentiometer
 Motor motion control

PIN ASSIGNMENT

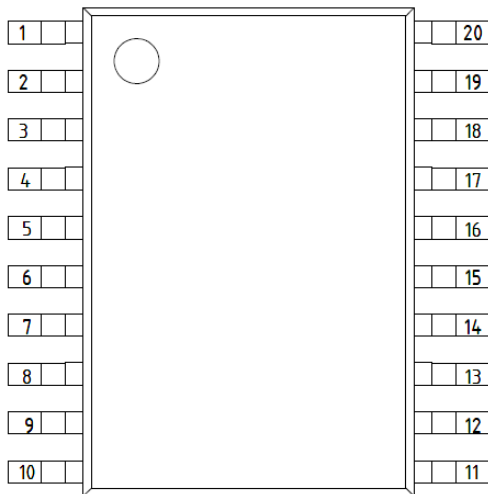

Pin No. KMA36 TSSOP	Symbol	Type	Description
1	A1	NC	Not connected
2	A0	I	Slave address config. pin
3	DVCC_SE	O	Drive pin to power sensor
4	SDA	I/O	Two-wire interface data pin
5	PWM	O	PWM output
6	SCL	I	Two-wire interface clock pin
7	GND_SE	S	Sensor supply ground pin
8	VCC_SE	S	Sensor power supply pin
9	NC	NC	Not connected
10	NC	NC	Not connected
11	NC	NC	Not connected
12	COILP	I	Coil power supply pin
13	COILN	I	Coil power supply pin
14	AREF	I	Asic analog reference
15	NC	NC	Not connected
16	GND_AS	S	Asic supply ground
17	NC	NC	Not connected
18	VCC_AS	S	Asic power supply
19	DCOILN	O	Drive pin to coil power supply
20	DCOILP	O	Drive pin to coil power supply

Figure 1: Pin assignment

ELECTRICAL CHARACTERISTICS

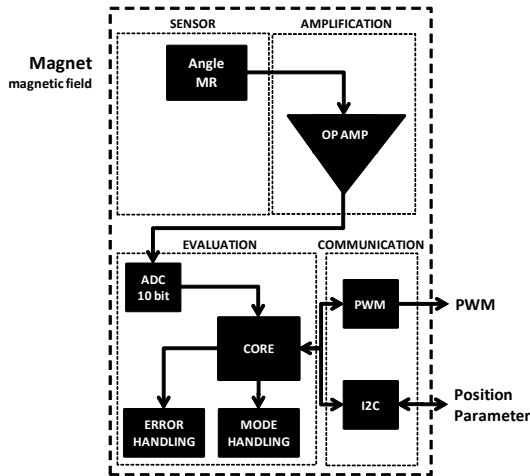

Unless otherwise specified, all voltages are referenced to the power ground supply VSS. Typical values are based on $T_{op} = 25^\circ\text{C}$, $V_{CC} = 5\text{V}$. They are given only as design guidelines and are not tested in production. Data based on characterization results, design simulation and/or technology characteristics are indicated in the table footnotes and are not tested in production.

Absolute maximum ratings are limiting values of permitted operation and should never be exceeded under the worst possible conditions either initially or consequently. If exceeded by even the smallest amount, instantaneous catastrophic failure can occur. And even if the device continues to operate satisfactorily, its life may be considerably shortened.

Figure 2: Functional block description

Absolute maximum ratings

CAUTION: Exceeding these values may destroy the product.

Symbol	Parameter	Condition	Min.	Typ.	Max.	Unit
T_{op}	Operating temperature		- 25		+ 85	$^\circ\text{C}$
T_{sto}	Storage temperature		- 40		+ 85	$^\circ\text{C}$
V_{cc}	Operating voltage		2.9		6.0	V
V_{in}	Input voltage on any Pin		-0.5		$V_{cc}+0.5$	V
I_{in}	DC Current through any I/O Pin				40	mA
I_{in}	DC Current through S Pin				200	mA
I_{in}	DC Current through any C Pin				60	mA

Table 1: Absolute maximum ratings

Operating conditions

Symbol	Parameter	Condition	Min.	Typ.	Max.	Unit
T_{op}	Operating temperature		- 25		+ 85	$^\circ\text{C}$
V_{cc}	Operating voltage		3		5.5	V
V_{in}	Input voltage on I/O pin		-0.3		$V_{cc}+0.5$	V
A_{Ref}	External Analog Reference ¹⁾		1.8	2.2	2.5	V
R_{AREF}	Analog Reference input resistance		-	32	-	k Ω

Table 2: Operating conditions

¹⁾ Apply 2.2V at AREF for best results

Please refer to the typical application section to know which external components should be connected.

◆ AC/DC characteristics

Symbol	Parameter	Condition	Min.	Typ.	Max.	Unit
I_{avg}	Average current ¹⁾	Except in sleep mode, $V_{cc} = 5V$	10		30	mA
I_{avg}	Average current ¹⁾	Except in sleep mode, $V_{cc} = 3V$	5		16	mA
I_{sleep}	Sleep current	$V_{cc} = 5V$ $V_{cc} = 3V$		2 0.5		mA
V_{IL}	Input low voltage		-0.5		$0.3 \times V_{CC}$	V
V_{IH}	Input high voltage		$0.6 \times V_{CC}$		$V_{CC} + 0.5$	V
V_{OL}	Output low voltage	$I_{OL} = 5 \text{ mA}$			0.6	V
V_{OH}	Output high voltage	$I_{OH} = 5 \text{ mA}$	$0.86 \times V_{CC}$			V

Table 3: AC/DC characteristics

1) Current measurement has been done with a standard circuit including a voltage divider on AREF.

◆ System parameters

Symbol	Parameter	Condition	Min.	Typ.	Max.	Unit
f_{data}	Update rate ^{1) 2)}		24		720	Hz
t_{start}	Starting time MCU			5		ms
t_{start}	Starting time PWM output			20		ms
α_{rd}	Resolution digital	$H_0=25$ kA/m, I2C mode ³⁾		13 ⁵⁾	15	Bit
α_{ra}	Resolution analog	$H_0=25$ kA/m, PWM mode ³⁾		10		Bit
$\Delta\alpha$	Accuracy ⁴⁾	$H_0=25$ kA/m ³⁾ $T_{op}=25^\circ\text{C}$, I2C mode, Oversampling=32		± 0.3	± 1	$^\circ$
$\Delta\alpha_H$	Hysteresis error (Repeatability) ⁴⁾	$H_0=25$ kA/m ³⁾ $T_{op}=25^\circ\text{C}$, I2C mode, Oversampling=32		± 0.1	± 0.25	$^\circ$
V_{bwn}	Brown-out reset voltage			2.7		V
t_{bwn}	Brown-out reset pulse width			2		μs
H_y	Applied magnetic field	PWR-Bit = 0	15	25	60	kA/m
R_{COIL}	Internal coil resistance		75	100	150	Ω
I_{COIL}	Internal coil current	$H_0=25$ kA/m	15	20	40	mA
f_{PWM}	PWM frequency			7.8		kHz

Table 4: System parameters

- 1) Maximum is measured in speed mode with minimum oversampling. Minimum is measured with maximum oversampling.
- 2) When using the analog-output configuration then update rate is fixed at 88Hz
- 3) System parameters apply only for recommended measurement setup (please refer to the arrangement section)
- 4) Hysteresis and accuracy are depending nearly inversely proportional on the magnetic field strength.
The accuracy is defined as the max. angular difference between actual field angle and measured angle.
The hysteresis is defined as angular difference between left and right turn
- 5) Using higher resolutions than 13 Bit may cause "missing bits" / increased linearity error.

Update rate

$$f_{\text{data}} = 1 / (1.4 \text{ msec} \times \text{oversampling} / \text{const})$$

SPD Bit	const
0	1
1	2

in [Hz]	I2C		Analog
Oversampling	normal mode	speed mode	
2	357	714	88
4	179	357	
8	89	179	
32	22	45	

SYSTEM OUTPUT

The system has two possible hardware output configurations: two-wire interface or analog output.

◆ Analog Output

The system has a Pulse Width Modulation unit with 10 bit resolution which can be easily coupled with a first order low-pass filter¹⁾ to generate an analog output between V_{ss} and V_{cc} corresponding to 0° and 360°. In this hardware configuration, all internal registers are loaded with initial values. No digital configuration is necessary, all available configurations can be set by changing the hardware setup²⁾ of the KMA36.

¹⁾ Please refer to the typical application section for further information.

²⁾ Please refer to the hardware configuration section for further information.

◆ I²C (Digital Output)

The KMA36 has an I²C Interface unit (two-wire interface, based on the standard I²C-bus specification defined by Philips Semiconductors) with an 8-bit data bus which can be easily used to retrieve measurement and configuration information. (Please refer to the two-wire interface section for details)

TWO WIRE IN INTERFACE

Physical interface parameters

Symbol	Parameter	Condition	Min.	Typ.	Max.	Unit
B_{rt}	Clockrate		1	50	100	kBit/s
A_L	Address length			7		bit
A_s	Address ¹⁾			0x59		Hex

Table 5: Physical interface parameters

1) Please refer to the hardware configuration section to determine how to configure other addresses.

Timing parameters

Symbol	Parameter	Condition	Min.	Typ.	Max.	Unit
$t_{SU:STA}$	Start setup time		4.7			μs
$t_{HD:STA}$	Start hold time		4.0			μs
$t_{SU:STO}$	Stop setup time		4.0			μs
t_{HIGH}	Clock high time		4.0		50	μs
t_{LOW}	Clock low time		4.7			μs
t_r	Rise time				1	μs
t_f	Fall time				0.3	μs
$t_{SU:DAT}$	Data input setup time		0.25			μs
t_{BUF}	Bus free time		4.7			μs

Table 6: Start, stop and data timing parameters

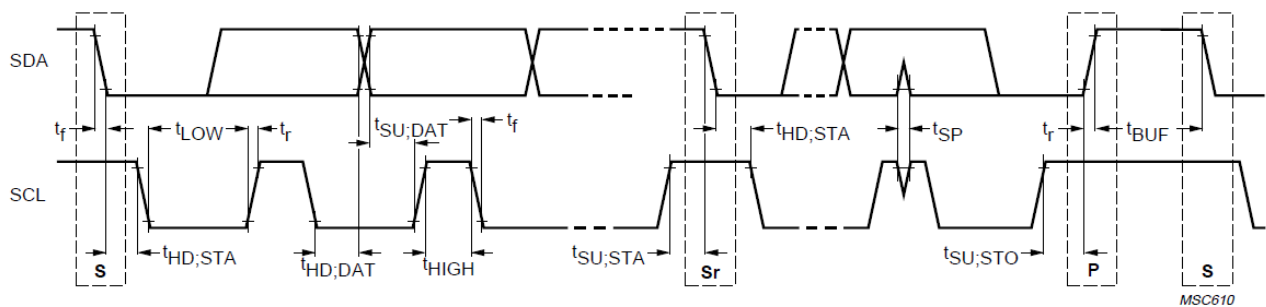

Figure 3: Timing definitions²⁾

²⁾ Please refer to the standard I²C-bus specification defined by Philips Semiconductors for further information.

◆ Registers (Overview)

The KMA36 contains the following I/O registers:

Registers of the KMA36			
Register	Size	Read/Write	Function
KCONF	8 bit	R/W	Configuration bits
KRES	16 bit	R/W	Resolution
MA	16 bit	R	Magnetic angle
ILC	32 bit	R	Incremental Counter

Table 7: Registers of the KMA36

◆ I²C Bus

The KMA36 is always operating as a pure slave.

◆ I²C Reading data

It is possible to read up to ten bytes as described in the following figure.

TWI - Read data										
Byte	0	1	2	3	4	5	6	7	8	9
	MA0	MA1	ILC0	ILC1	ILC2	ILC3	KCONF	KRESL	KRESH	CSSEND
Read/Write	R	R	R	R	R	R	R	R	R	R
Initial value	0x00	0x00	0x00	0x00	0x00	0x00	0x03	0x00	0x04	

Byte 0:1 - MA1:0: Magnetic angle
 Unsigned integer giving the magnetic angle in degree with the configured resolution

Byte 2:5 - ILC3:0: Incremental linear counter
 Signed long giving the incremental linear counter in degree with the configured resolution.

Byte 6 - KCONF: Configuration register
 Unsigned char giving the configuration register value.

Byte 8:7 - KRES: Resolution register
 Contains the desired resolution.

Byte 9 - CSSEND: Checksum - Senddata (Low-Byte of sum of Byte[0..9])

Table 8: Read data

◆ I²C Writing data (general)

The KMA36 can be controlled using two internal registers. The configuration (KCONF) is an 8-bit register and the resolution (KRES) is a 16-bit register. To write the 16-bit register (KRES) through the two-wire interface with an 8-bit data bus, it is necessary to send the high byte first and then the low byte.

In order to change the KMA configuration, four bytes should be sent through the two-wire 8-bit data bus. The first three bytes correspond to the configuration and resolution registers. The last byte contains a 8-Bit Cyclic Redundancy Check (CRC) value which can be calculated as described in the example.

After writing via I2C the KMA36 needs 60ms + time of 2 measurements (with new configuration) to process to data (worst case at 22Hz update rate = 151ms). Initiating any I2C communication within this period may cause unpredictable behavior.

TWI - Send data				
Byte	0	1	2	3
	KCONF	KRESH	KRESL	KCS
Read/Write	W	W	W	W
Initial value	-	-	-	-

Byte 0: KCONF: Configuration register
 Contains the desired system configuration.

Byte 1:2 - KRES: Resolution register
 Contains the desired resolution.

Byte 3 - KCS:
 Checksum
 Contains the checksum.

Table 9: Send data

Example

	KCONF	KRESH	KRESL	KCS
data	0x03	0x7F	0xFF	0x7F
	$\boxed{\text{KCS}} = 0xFF - (\text{KCONF} + \text{KRESH} + \text{KRESL}) + 0x01$			
	$\boxed{\text{KCS}} = 0xFF - (0x03 + 0x7F + 0xFF) + 0x01 = 0x7F$			

Table 10: CS Example

◆ KCONF (Configuration register)

The configuration register is used to control and monitor the status and modes of the system:

KCONF - Configuration register								
Bit	7	6	5	4	3	2	1	0
	SLP	-	LIN	CNT	PWR	SPD	OVCS1	OVSC0
Read/Write	W	R/W	R/W	R/W	R/W	R/W	R/W	R/W
Initial value	0	0	0	0	0	0	1	0

Bit 7 - SLP: Sleep mode

Writing this bit to one enables the sleep mode. This bit will be always set to zero by hardware.

Bit 5 - LIN: Mode

Writing this bit to one disables the rotational mode and enables the linear mode.

Bit 4 - CNT: Mode

Writing this bit to one enables the incremental counter mode. By writing it to zero, the counter mode is turned off and reset

Bit 3 - PWR: Low power mode

Writing this bit to one enables the low power mode.

Bit 2 - SPD: Speed mode

Writing this bit to one enables the fast speed mode.

Bit 1:0 - OVCS1:0: Oversampling

These bits determines the accuracy of the angle evaluation.

Table 11: KCONF – Configuration Register

- ◆ Rotational measurement used to measure the angle of a rotating magnet disc centered above the magnetic sensor center of the KMA36. ¹⁾
- ◆ Linear measurement used to measure the linear movement of the KMA36 along a magnetic pole strip with 5mm pole length. A lookup table is used for internal error correction ¹⁾
- ◆ Sleep mode used to power down the KMA36. Wake up is initiated by I²C communication

¹⁾ Please refer to the arrangement section.

◆ **SLP-Bit (KCONF register)**

Writing a “1” to this Bit will activate the sleep mode. The KMA36 will power down to sleep mode. To wake up the KMA36 please follow this procedure:

- ◆ Initiate a I2C read (minimum 1 byte) on any I2C address (The KMA36 will wake up temporarily)
- ◆ Wait 10..15 ms
- ◆ Initiate a I2C read (minimum 1 byte) on the I2C address of the KMA36 (The KMA36 will keep awake and start a new measurement)

◆ **LIN-Bit (KCONF register)**

Writing a “1” to this Bit will activate the linear measurement mode. This mode is used to measure the linear movement of the KMA36 along a magnetic pole strip with 5mm pole length. A lookup table is used for internal error correction. Please refer to the arrangement section.

Writing a “0” to this Bit will activate the rotational measurement mode. This mode is used to measure the angle of a rotating magnet disc centered above the magnetic sensor center of the KMA36. Please refer to the arrangement section.

◆ **CNT-Bit (KCONF register)**

In addition, there is an incremental counter implemented, which can be enabled by writing a one to the CNT-Bit in the KCONF register.

◆ **PWR-Bit (KCONF register)**

The current consumption can be reduced with the low power mode accessible through the PWR bit. In low power mode only 180° measurement are possible.

◆ **SPD-Bit (KCONF register)**

The measurement update rate can be increased by activating the fast mode with SPD bit. In fast mode measurement accuracy is reduced.

<u>Update rate</u>	
$f_{data} = 1 / (1.4 \text{ msec} \times \text{oversampling} / \text{const})$	
SPD Bit	const
0	1
1	2

Table 12: Update rate

◆ **OVCS-Bits (KCONF register)**

To increase the measurement accuracy, it is possible to configure the oversampling rate by using the OVSCx bits. Please notice that a higher accuracy leads to a reduction of the update rate (Please refer to the Update rate table)

OVS1	OVS0	Oversampling
0	0	2
0	1	4
1	0	8
1	1	32

Table 13: OVSC - Oversampling

◆ **KRES (Resolution register)**

The resolution can be set to any decimal value between 1 and 32768. Any other value would lead to unexpected system behavior.

KRES - Resolution register

Bit	15	14	13	12	11	10	9	8
KRESH	KRES15	KRES14	KRES13	KRES12	KRES11	KRES10	KRES9	KRES8
KRESL	KRES7	KRES6	KRES5	KRES4	KRES3	KRES2	KRES1	KRES0
Bit	7	6	5	4	3	2	1	0
Read/Write	W	W	W	W	W	W	W	W
Initial value	0	1	1	1	1	1	1	1
	1	1	1	1	1	1	1	1

Bit 15:0 KRES15:0:
Resolution

Table 14: KRES - Resolution Register

For example, a resolution of decimal 360 (0x00168) leads to rotational data in steps of 1 degree. A resolution of decimal 3600 (0x0E10) results in steps of 0.1°.

HARDWARE CONFIGURATION

The hardware configuration depends on the desired output: two-wire interface or (analog) PWM output.

In both modes it is not allowed to left pin A0 floating / unconnected.

In two-wire interface configuration, the slave address of the system can be configured by connecting A0 and another pin as described in following table.

TWI - Slave address configuration

Address	Connection	
0x59	A0	GND
0x5A	A0	DCOILP
0x5B	A0	DCOILN
0x5C	A0	DVCC_SE
0x5D	A0	VCC

Table 15: TWI / I²C Slave address configuration

In analog mode, the rotation direction can be configured by connecting DVCC_SE and a power supply pin. The user zero reference angle calibration can be activated by connecting A0 and COILP. When the user zero reference angle calibration is active, the next evaluated magnetic angle will be set as the new zero reference angle. The user selectable output voltage for the zero reference angle can be configured by connecting A0 in series with a 4,7k ohm resistor and a port pin. The percentage indicated is relative to the power supply value Vcc and is defined at the zero reference angle position.

ANALOG - Rotation direction configuration

Direction	Connection	
CW	DVCC_SE	VCC
CCW	DVCC_SE	4,7K to GND

ANALOG - User selectable output for zero reference

Percent	Connection	
0%	A0	4,7K to VCC
10%	A0	4,7K to DVCC_SE
25%	A0	4,7K to DCOILN
50%	A0	4,7K to GND

ANALOG - Zero reference angle user calibration

Status	Connection	
Active	A0	COILP
Inactive	A0	-

Table 16: Analog-Mode configuration

TYPICAL APPLICATION

◆ Electrical circuit

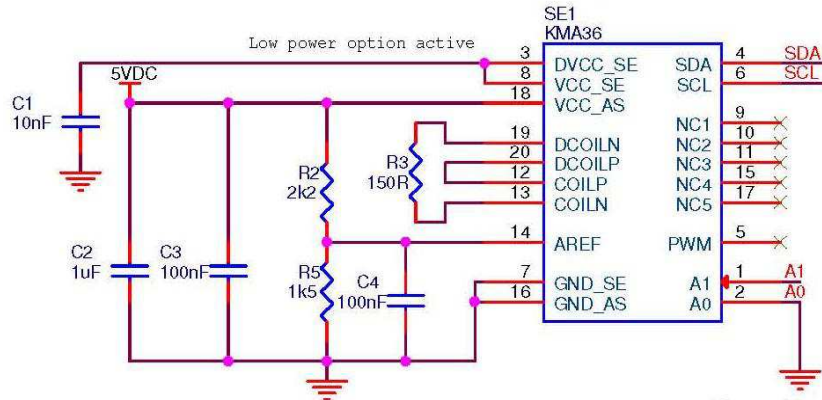

Figure 4: Typical circuit with two-wire interface

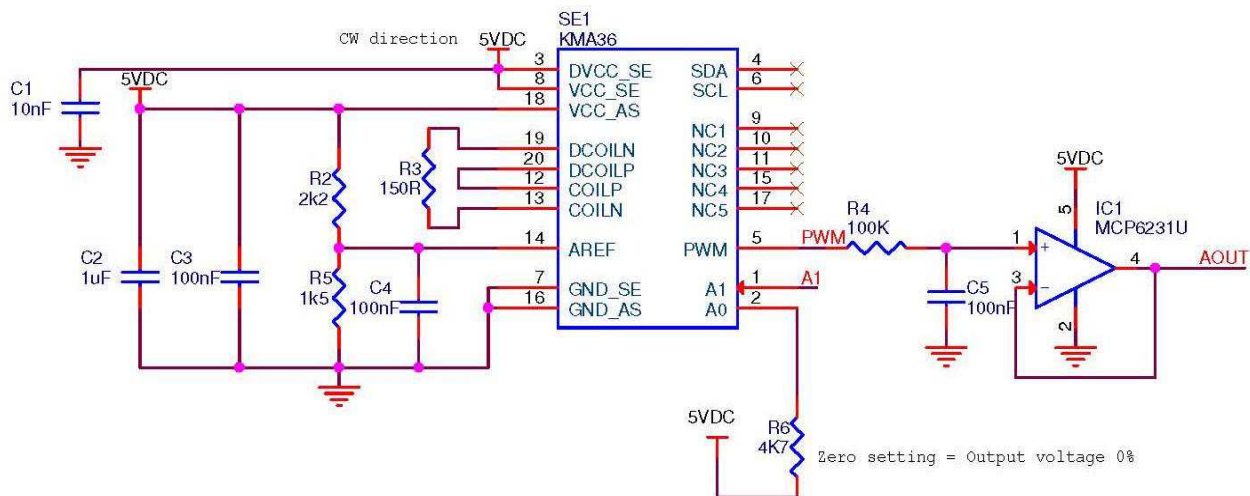

Figure 5: Typical circuit with analog interface

ARRANGEMENT

Due to the magneto resistive technology which senses the magnetic field in the sensor plane, it is advised to mount the magnet disc centered above the sensor center. Please refer to the magnets and scales section for more information about the magnetic center position of the KMA36. The magnetic scale should be placed perpendicularly to the KMA36 as depicted in the following figure rather in the middle along the width of the scale. For best results the KMA36 should be as close as possible to the magnet.

◆ Rotational (recommended) setup (for best results)



Rotational mode
Bit LIN = 0

Pay attention to the magnetic center of the KMA36

◆ Linear setup

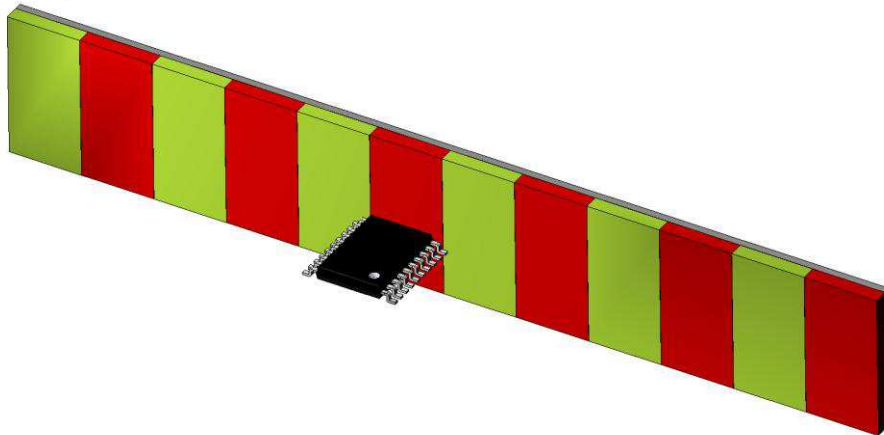

Linear mode
Bit LIN = 1

use magnetic pole strip with 5mm pole length for best results

Figure 6: Mounting

MAGNETS AND SCALES

Rotational Mode

The KMA36 can be used with a magnet, preferably of disc or square shape or a magnet scale with pole pitch 5mm.

For development purposes, MEAS offers a magnet disc made of plastic bonded Nd-Fe-B magnetic material which provides an homogenous magnetic field with sufficient magnetic field strength for typical application with the KMA36. The following table describes typical magnets parameters. Please refer to the website <http://www.magnetfabrik.de> (article number 67.044-1) and its application note section for more information.

Symbol	Parameter	Condition	Min.	Typ.	Max.	Unit
Ø	Diameter	Neofer 48/60p only		14		mm
T	Thickness	Neofer 48/60p only		2.5		mm
B _r	Magnetic field strength	Neofer 48/60p only		540		mT
T _{op}	Operating temperature	Neofer 48/60p only			150	°C

Table 17a: Typical MEAS disc-magnet specification

Linear Mode

The linear mode of the KMA36 is designed for a magnetic scale with pole pitch 5mm. A magnetic scale is made of a magnetic ferrite tape bonded on a steel support which guarantees mechanical stability. The steel support is made of an optimum stainless steel alloy that provides no loss of magnetic field strength. MEAS offers a standard scale with the following parameters for development purpose:

Symbol	Parameter	Condition	Min.	Typ.	Max.	Unit
L _T	Length	MEAS magnetic scale only		1		m
L _P	Pole length	MEAS magnetic scale only		5		mm
W	Width	MEAS magnetic scale only		10		mm
T	Thickness	MEAS magnetic scale only		1.3		mm
Δp	Accuracy	MEAS magnetic scale only		40		μm/m
T _{op}	Operating temperature	MEAS magnetic scale only	-40		100	°C

Table 17b: Typical MEAS magnet-scale specification

The correct magnet dimensions and assembly geometry depend on the specific arrangement of the application and are part of the specification of the entire system.

PACKAGE DRAWING

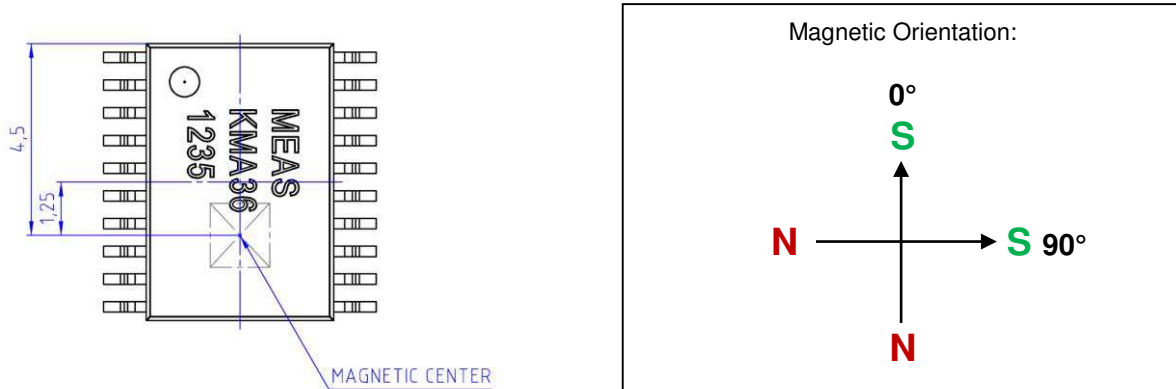

Figure 7: Package drawing (Magnetic center & Magnetic orientation)

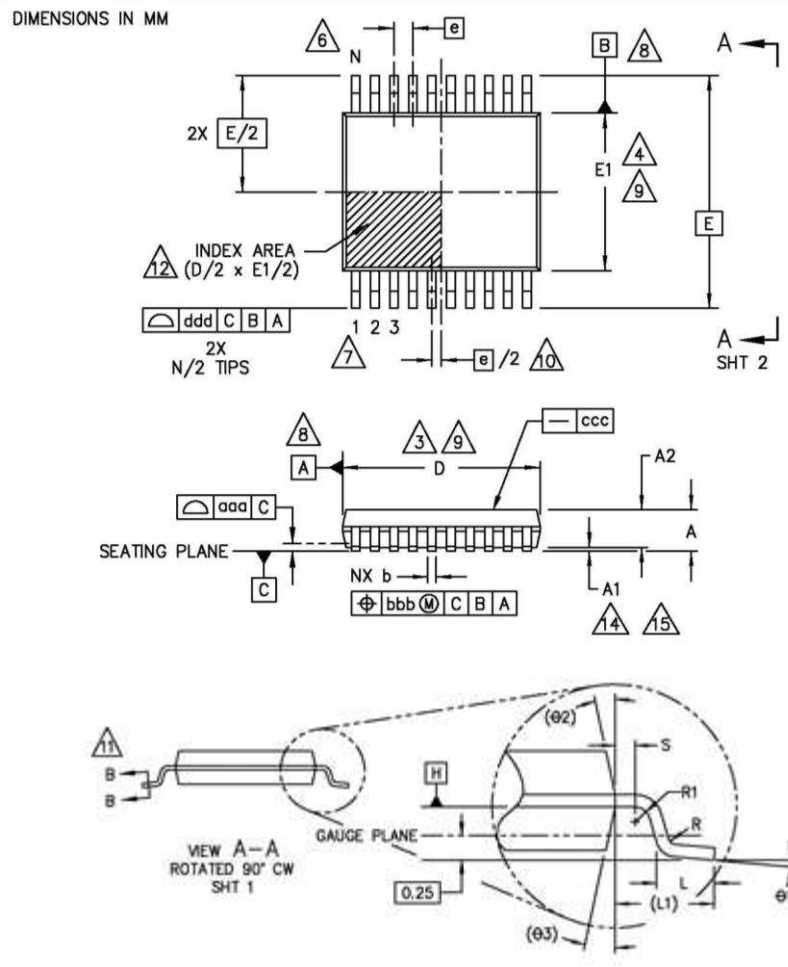

Figure 8: Package drawing

COMMON DIMENSIONS (MILLIMETERS)			
Symbol	Min.	Typ.	Max.
A	-	-	1.20
A1	0.05	-	0.15
A2	0.80	1.00	1.05
b	0.19	-	0.30
D	6.40	6.50	6.60
E	-	6.40	-
E1	4.30	4.40	4.50
e	-	0.65	-
L	0.45	0.60	0.75
N	-	20	-
R	0.09	-	-
S	0.20	-	-
∠1	0°	-	8°

Table 18: common dimensions

ORDERING CODE

Product	Description	Article number
KMA36	KMA36 TSSOP20	G-MRMO-031

Table 19: Ordering codes

This data sheet contains data from the preliminary specification. Supplementary data will be published later. Measurement Specialties reserves the right to change the specification without notice, in order to improve the design and performance of the product.