



## MS4525

### SPECIFICATIONS

- **PCB Mounted Pressure Transducers**
- **Amplified Ratiometric Analog Output**
- **Differential, Gage, Absolute, Compound, & Vacuum**
- **Temperature Compensated**
- **3.3 or 5.0 Vdc Supply Voltage**

The MS4525 is a small, ceramic based, PCB mounted pressure transducer from Measurement Specialties. The transducer is built using Measurement Specialties' proprietary UltraStable™ process and the latest CMOS sensor conditioning circuitry to create a low cost, high performance transducer designed to meet the strictest requirements from OEM customers.

The MS4525 is fully calibrated and temperature compensated with a total error band (TEB) of less than 1.0% over the compensated range. The sensor operates from single supply of either 3.3 or 5.0Vdc and requires a single external component for proper operation.

The rugged ceramic transducer is available in side port, top port, and manifold mount and can measure absolute, gage, differential, or compound pressure from 1 to 150psi. The 1/8" barbed pressure ports mate securely with 3/32" ID tubing.

## FEATURES

- PSI Pressure Ranges
- PCB Mountable
- High Level Analog Output
- Barbed Pressure Ports

## APPLICATIONS

- Blocked Filter Detection
- Altitude and Airspeed Measurements
- Medical Instruments
- Fire Suppression System
- Panel Meter
- Air Movement/Environmental Controls
- Pneumatic Controls

## STANDARD RANGES (PSI)

Pressure	Absolute	Gage	Differential	Compound	Vacuum	Option Availability
1		DS, SS, TP, MM	DS, SS, TP			-F
2		DS, SS, TP, MM	DS, SS, TP			-F
5		DS, SS, TP, MM	DS, SS, TP			-F
15	SS, TP	DS, SS, TP, MM	DS, MM	SS, TP	SS, TP, DS	-F
30	SS, TP	DS, SS, TP, MM	DS, MM	SS, TP		-F
50	SS, TP	DS, SS, TP, MM	DS, MM	SS, TP		-F
100	SS, TP	DS, SS, TP, MM	DS, MM	SS, TP		-F
150	SS, TP	DS, SS, TP, MM	DS, MM	SS, TP		-F

See Package Configurations: DS= Dual Side Port, SS= Single Side Port, TP= Top Port, MM= Manifold Mount  
 Pin Style "L" is only available SS and MM port types.  
 Pin Style "C" is only available SS, TP and MM port types.

BLOCK DIAGRAM

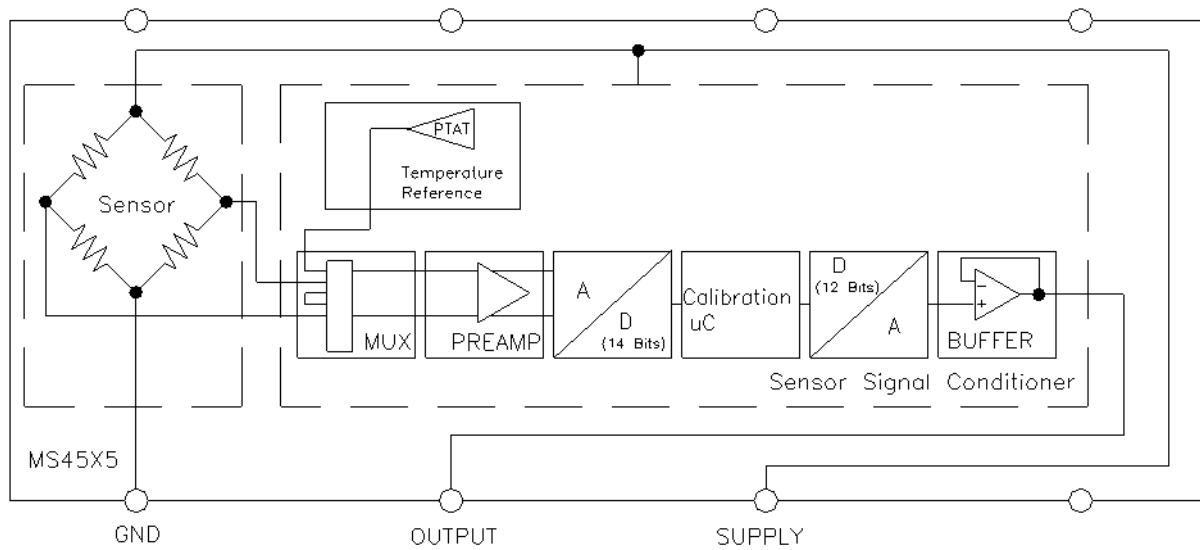

ABSOLUTE MAXIMUM RATINGS

Parameter	Conditions	Min	Max	Unit	Notes
Supply Voltage	T <sub>A</sub> = 25 °C	2.7	5.5	V	
Output Current	T <sub>A</sub> = 25°C		3	mA	
Load Resistance (R <sub>L</sub> )	T <sub>A</sub> = 25°C	10		kΩ	
Storage Temperature		-40	+125	°C	
Humidity	T <sub>A</sub> = 25°C		95	%RH	Non Condensing
Overpressure	T <sub>A</sub> = 25 °C, both Ports	Not to Exceed 300		psi	
Burst Pressure	T <sub>A</sub> = 25 °C, Port 1			psi	See Table 1
ESD	HBM	-4	+4	kV	EN 61000-4-2
Solder Temperature		250°C, 5 sec max.			

TABLE 1- BURST PRESSURE BY RANGE AND PACKAGE STYLE

Range	DS	TP, SS, MM	Unit
001	20	20	psi
002	20	20	psi
005	15	20	psi
015	45	90	psi
030	90	200	psi
050	150	300	psi
100	300	300	psi
150	300	300	psi

## ENVIRONMENTAL SPECIFICATIONS

Parameter	Conditions
Mechanical Shock	Mil Spec 202F, Method 213B, Condition C, 3 Drops
Mechanical Vibration	Mil Spec 202F, Method 214A, Condition 1E, 1Hr Each Axis
Thermal Shock	100 Cycles over Storage Temperature, 30 minute dwell
Life	1 Million FS Cycles
MTTF	>10Yrs, 70 °C, 1.188 Million Pressure Cycles, 120%FS Pressure

## PERFORMANCE SPECIFICATIONS

Supply Voltage<sup>1</sup>: 5.0V or 3.3 Vdc

Ambient Temperature: 25°C (unless otherwise specified)

PARAMETERS	MIN	TYP	MAX	UNITS	NOTES
Accuracy	-0.25		0.25	%Span	2
Total Error Band (TEB)	-1.0		1.0	%Span	3,5
Supply Current		3		mA	5
Compensated Temperature	-10		+85	°C	4
Operating Temperature	-25		+105	°C	
Response Time		1		mS	5
Weight		3		grams	
Media	Non-Corrosive Dry Gases Compatible with Ceramic, Silicon, Borosilicate Glass, RTV, Gold, Aluminum and Epoxy. See "Wetted Material by Port Designation" chart below.				

## Notes

1. Proper operation requires an external capacitor placed as shown in Connection Diagram. Output is ratiometric to supply voltage variations of less than 10%.
2. The maximum deviation from a best fit straight line (BFSL) fitted to the output measured over the pressure range at 25°C. Includes all errors due to pressure non linearity, hysteresis, and non repeatability.
3. Total error band includes all accuracy errors, thermal errors over the compensated temperature range, and span and offset calibration tolerances. For ideal sensor output with respect to input pressure, reference Pressure Transfer Function charts below. TEB values are valid only at the calibrated supply voltage.
4. For errors beyond the compensated temperature range, see Extended Temperature Multiplier chart below.
5. This product can be configured for custom OEM requirements, contact factory for lower power consumption or higher accuracy.

## CONNECTION DIAGRAM

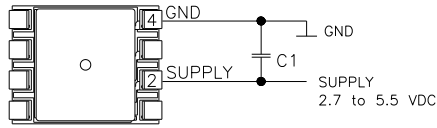

**Notes**

- 1. Place 100nF capacitor between Supply and GND to within 2 cm of sensor.

## PRESSURE AND TEMPERATURE TRANSFER FUNCTION

Pressure Transfer Functions, Supply=5V

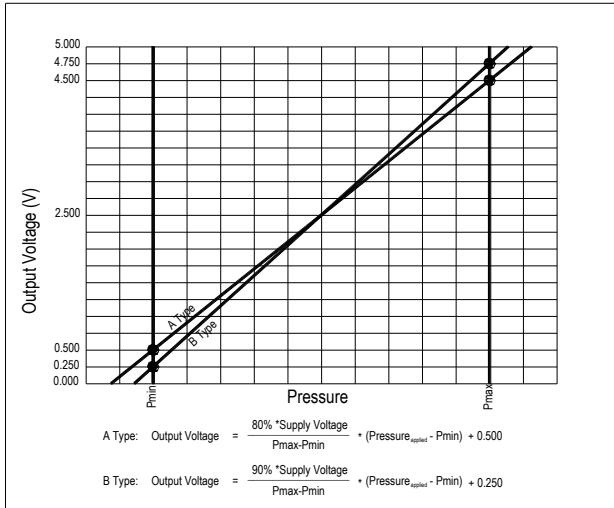

Pressure Transfer Functions, Supply=3.3V

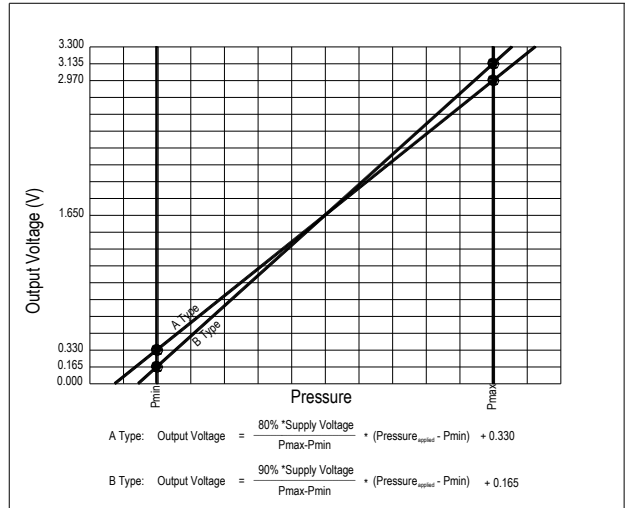

## EXTENDED TEMPERATURE MULTIPLIER CHART

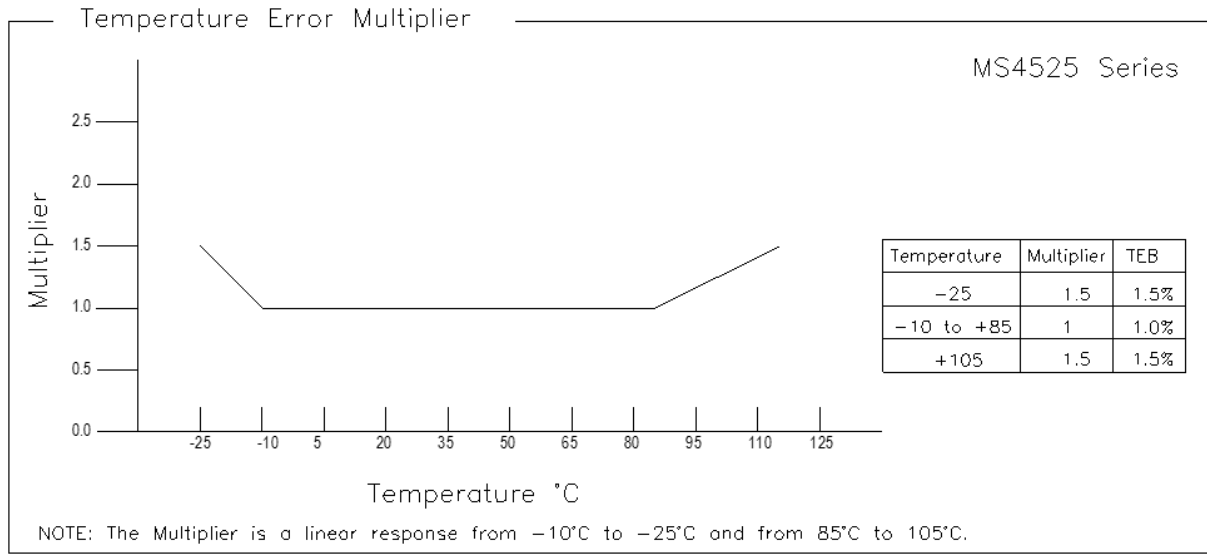

## PACKAGE, PINOUT & PRESSURE TYPE CONFIGURATION

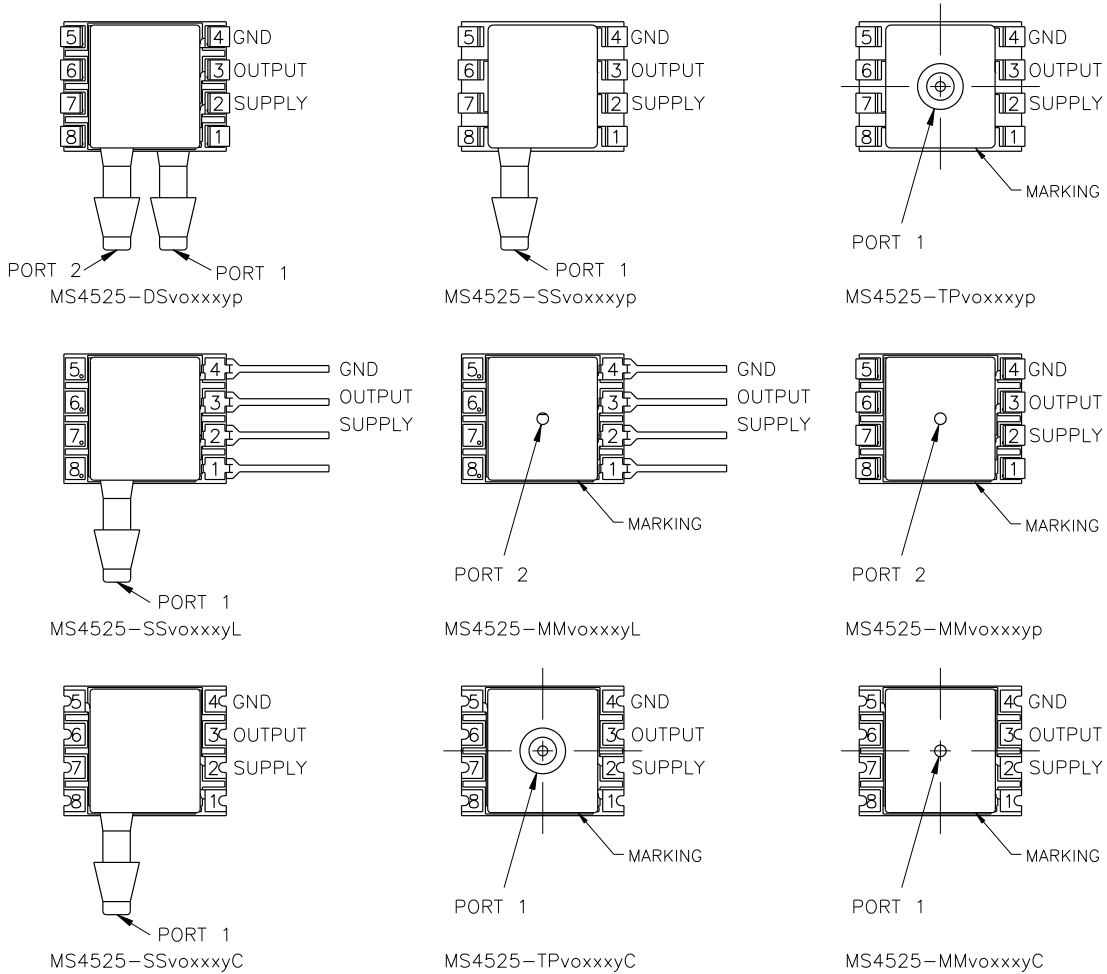

Pin Name	Pin	Function
SUPPLY	2	Positive Supply Voltage
OUTPUT	3	Analog Output
GND	4	Ground
	1, 5-8	No Connection

Pressure Type	Pmin	Pmax	Description
Absolute	0psiA	+Prange	Output is proportional to the difference between 0psiA (Pmin) and pressure applied to Port 1.
Differential/ Bidirectional	-Prange	+Prange	Output is proportional to the difference between Port 1 and Port 2. Output swings positive when Port 1 > Port 2. Output is 50% of supply voltage when Port 1=Port 2.
Gage	0psiG	+Prange	Output is proportional to the difference between 0psiG (Pmin) and Port 1. Output swings positive when Port 1 > Port 2.
Compound	-15psiG	+Prange	Output is proportional to the difference between -15psiG pressure (Pmin) and pressure applied to Port 1.

Prange is equal to the maximum full scale pressure specified in the ordering information.

### WETTED MATERIAL BY PORT DESIGNATION

Style	Port	Material						
		Ceramic	Silicon	Borosilicate Glass	RTV	Gold	Aluminum	Epoxy
DS, MM	Port 1	X	X	X	X			X
	Port 2	X	X	X	X	X	X	X
SS, TP, SM	Port 1	X	X	X	X	X	X	X

"X" Indicates Wetted Material

DIMENSIONS (are in INCHES [mm])

Model: MS4525-DSvoxxxyp

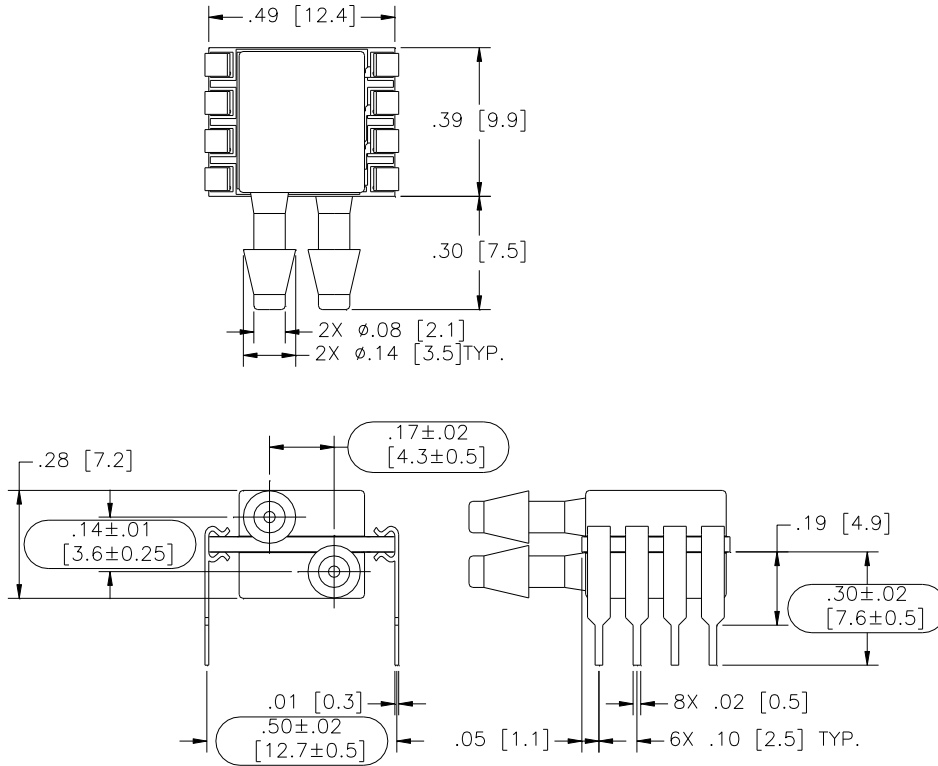

Model: MS4525-DSvoxxxys

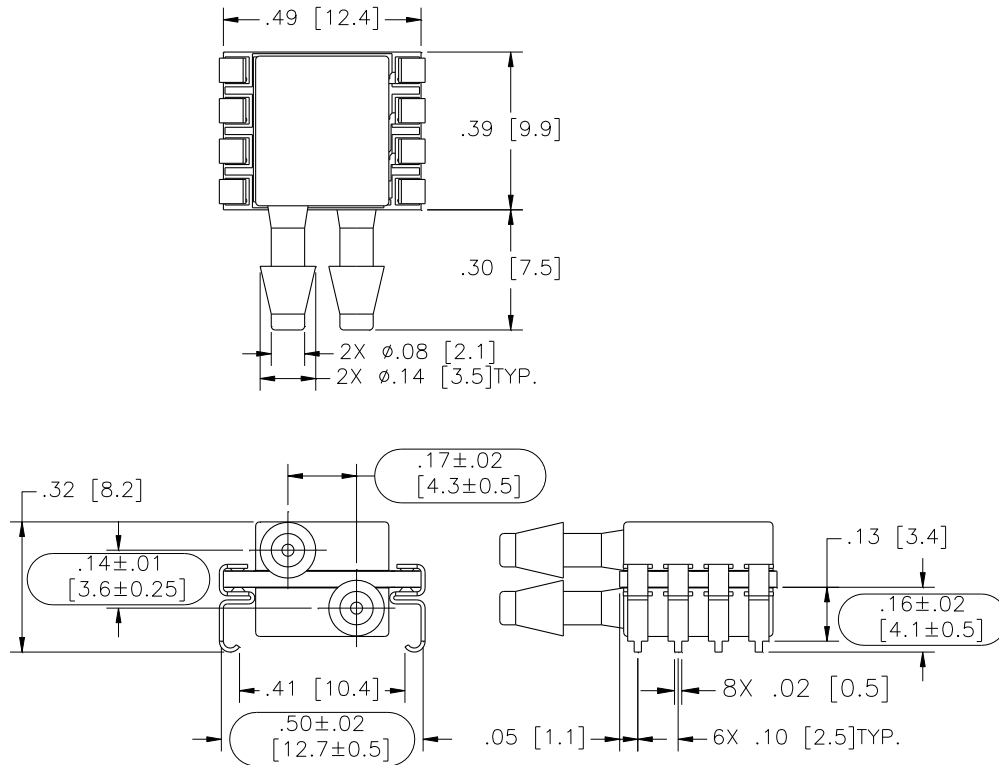



Model: MS4525-SSvoxxxyp

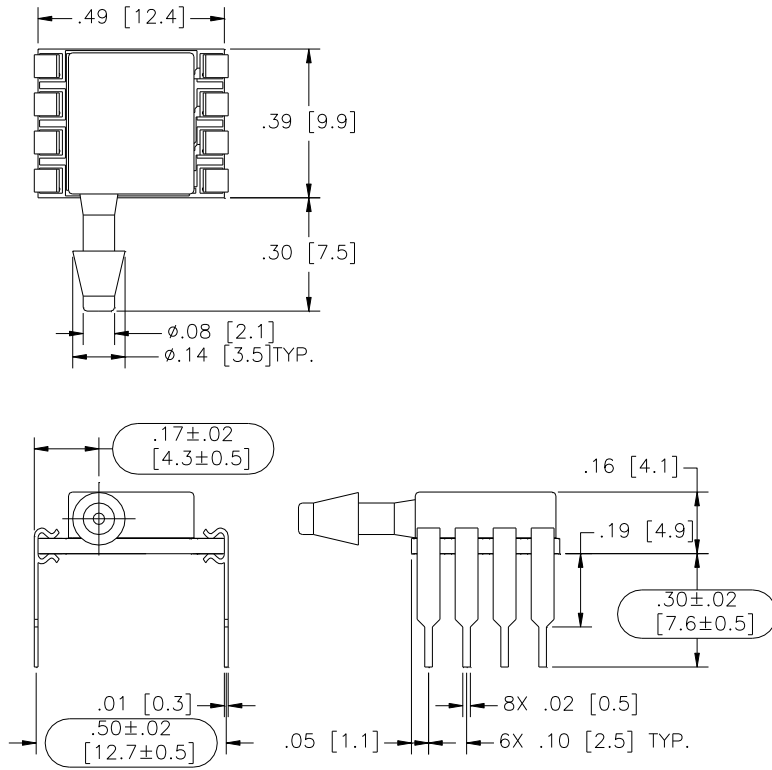

Model: MS4525-SSvoxxxys

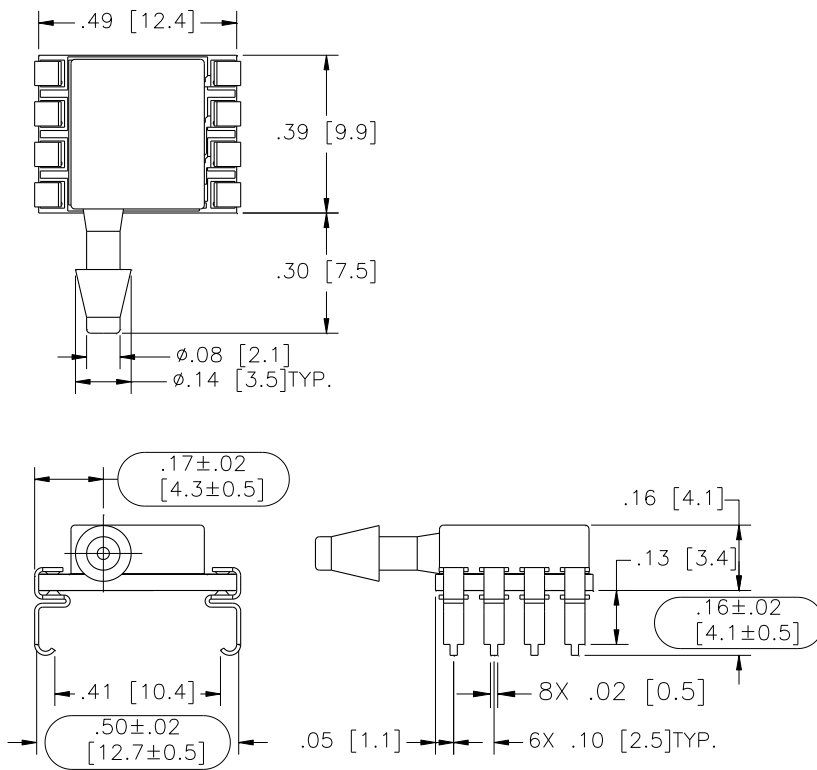

Model: MS4525-TPvoxxxYP

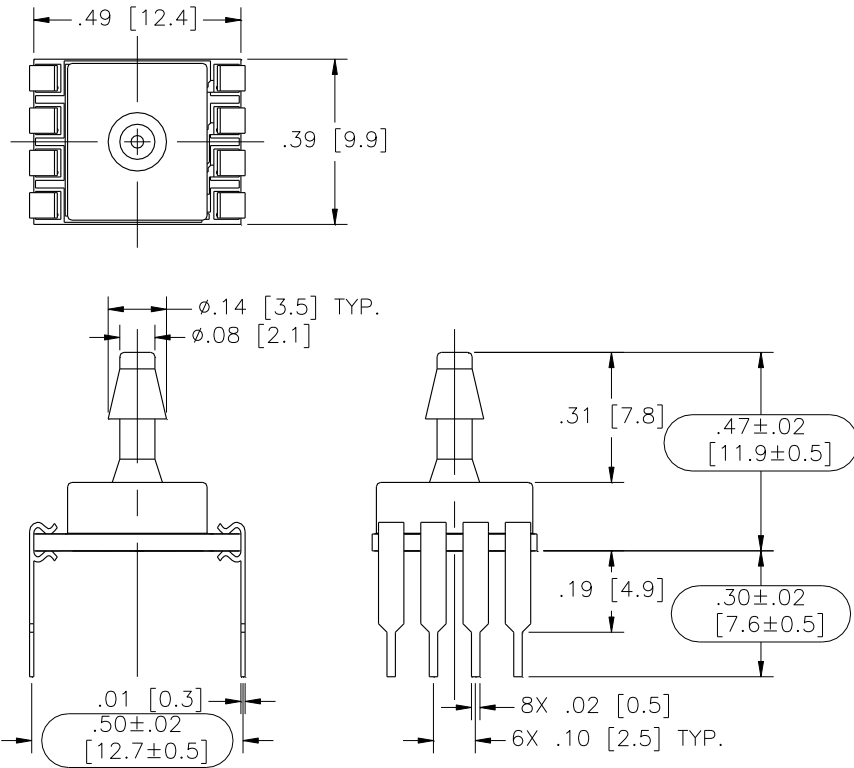

Model: MS4525-TPvoxxxYS

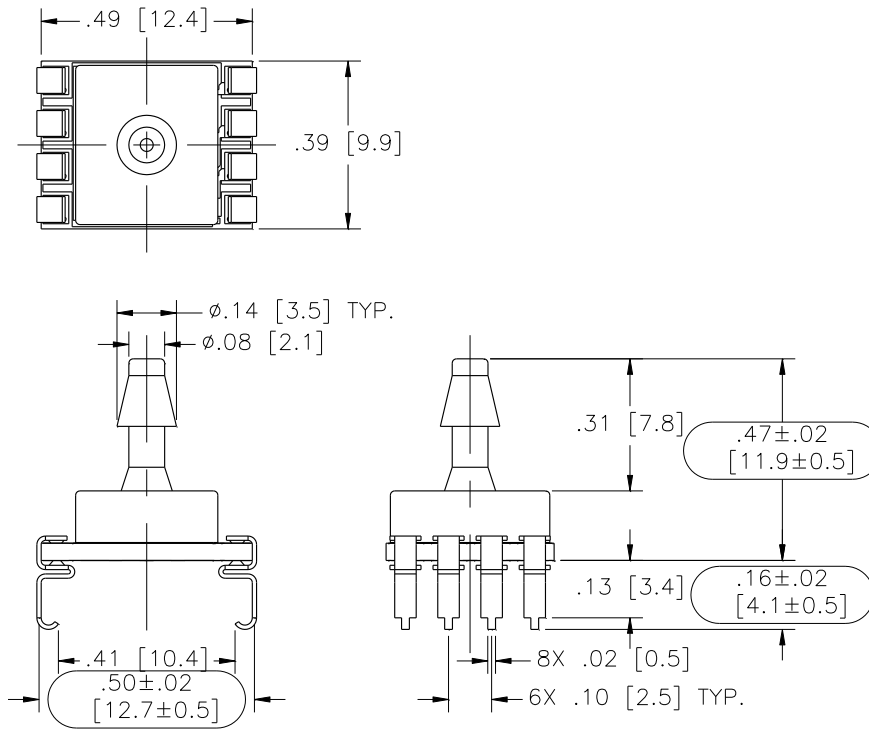

**MS4525**

Model: MS4525-SSvoxxxyl

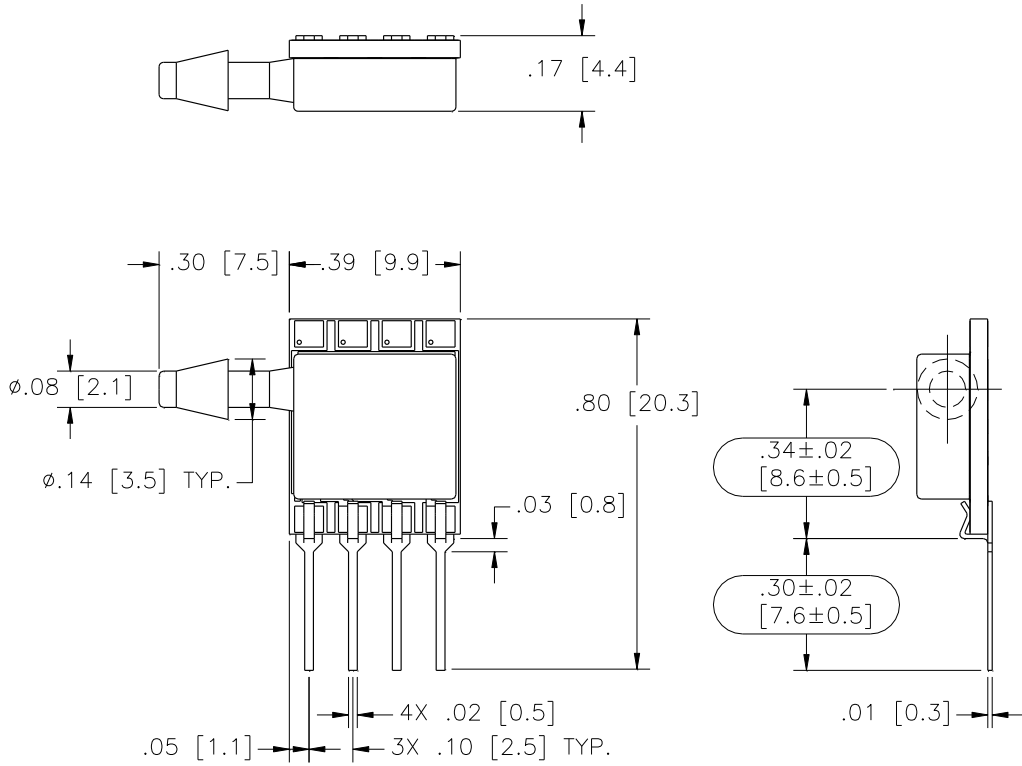

Model: MS4525-MMvoxxxyl

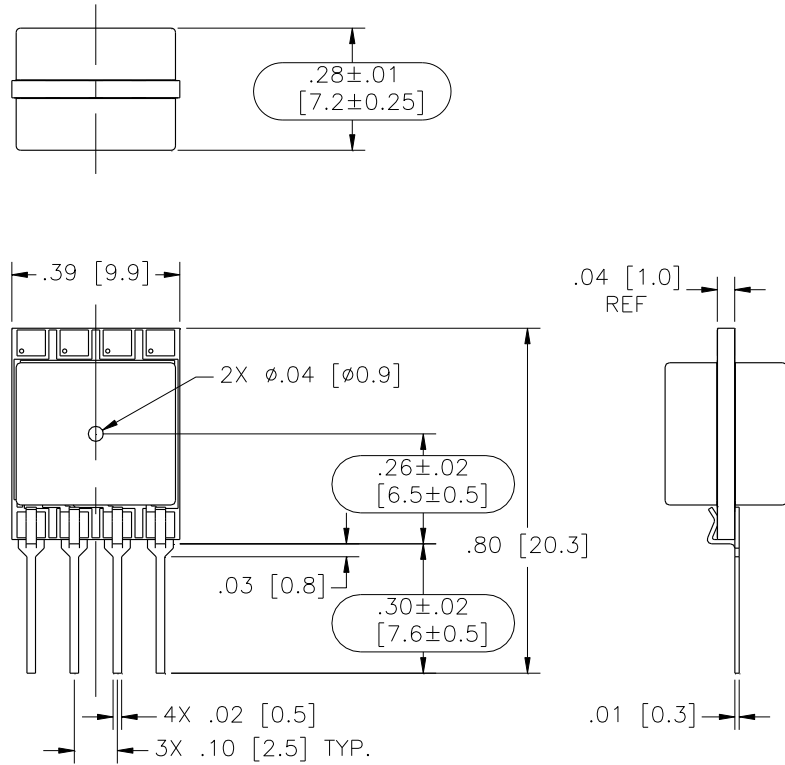

Model: MS4525-MMvoxxxyP

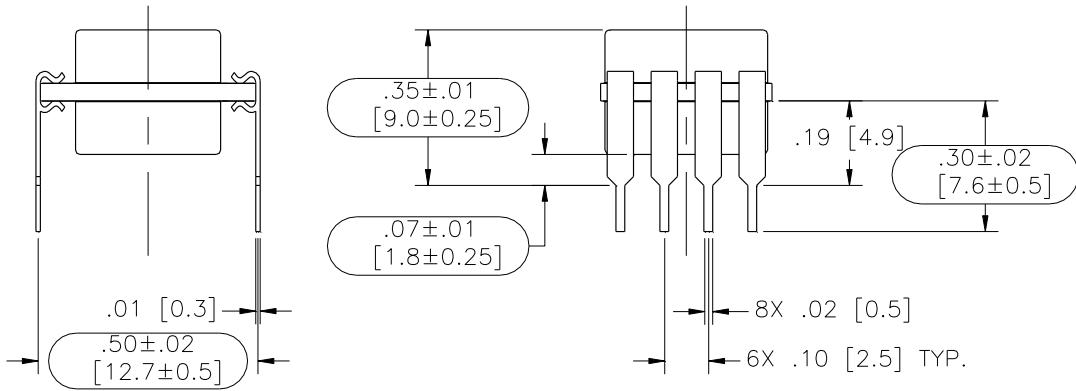
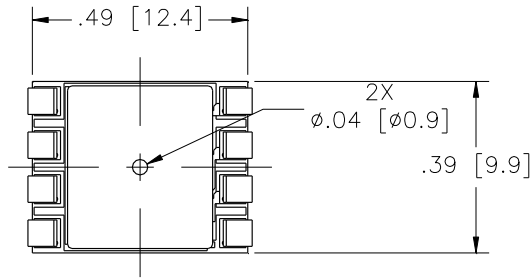

Model: MS4525-MMvoxxxyS

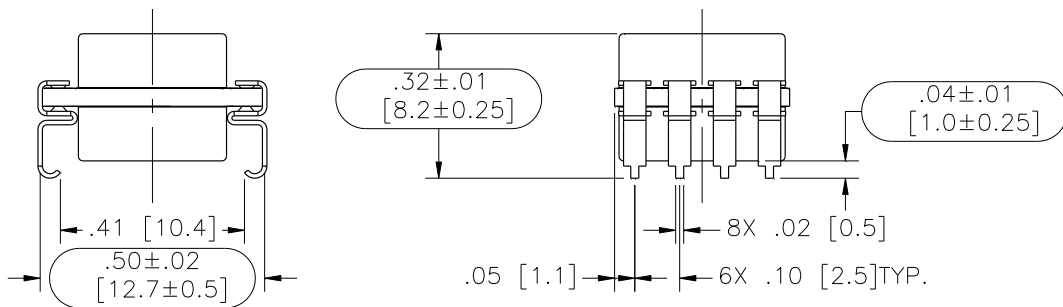
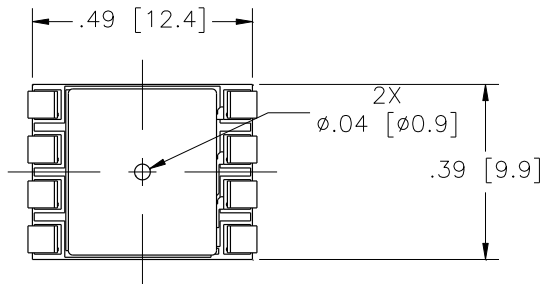

Model: MS4525-SSvoxxxyC

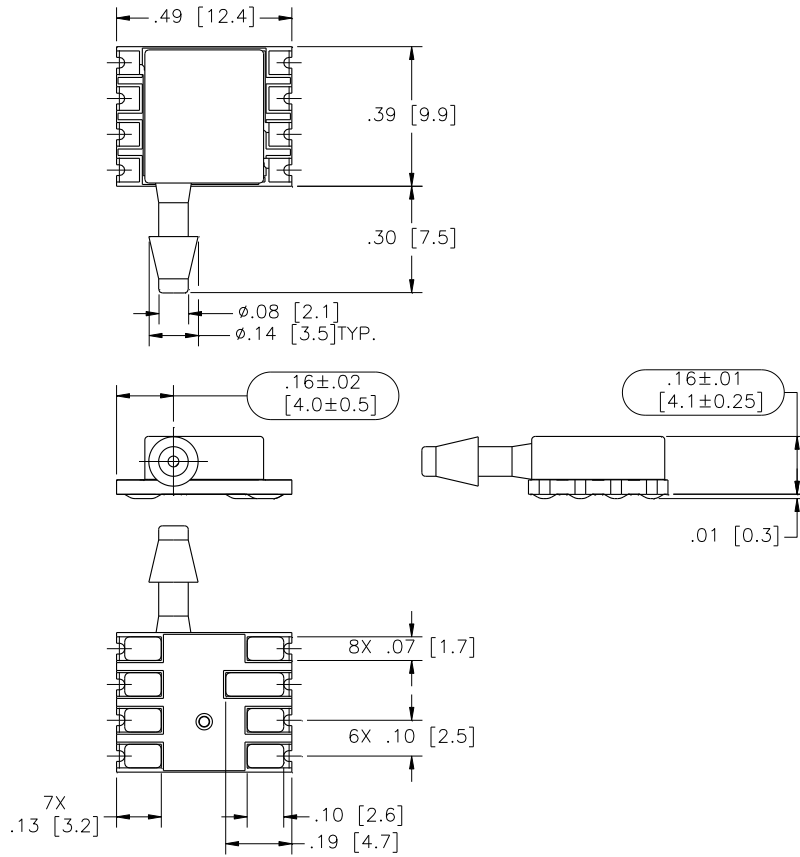

Model: MS4525-TPvoxxxyC

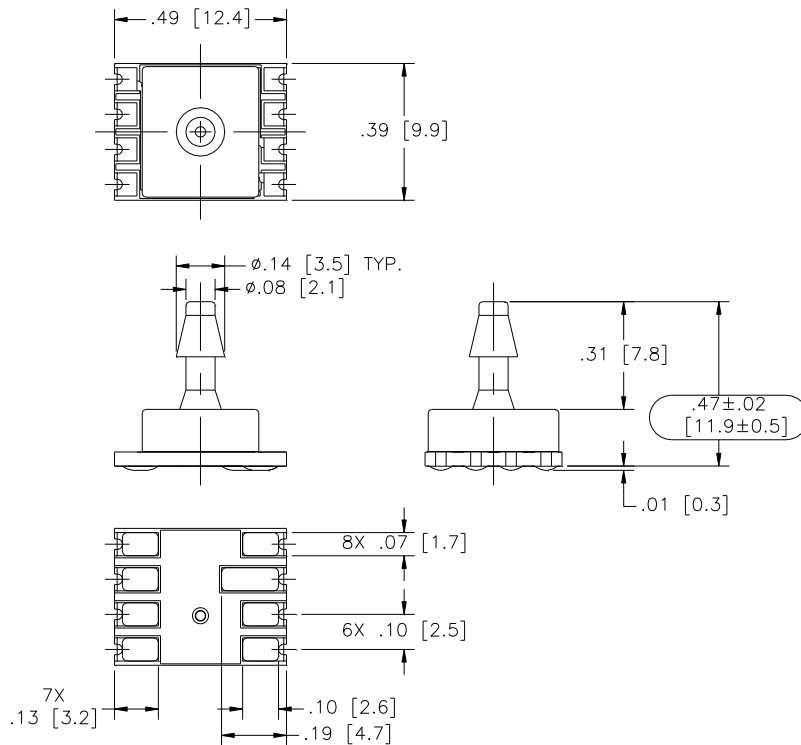

Model: MS4525-MMvovxxyC

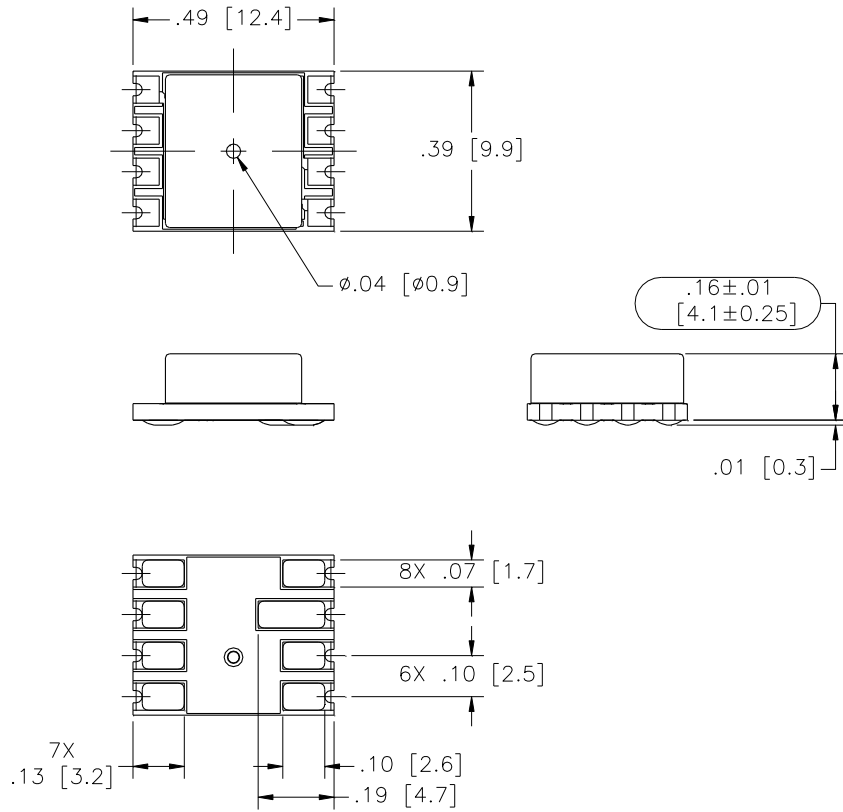

## AVAILABLE OPTIONS

## Gel Coat (-F Option)

The MS4525 is designed for non ionic and clean dry air applications. Select this option for added protection in high humidity or slightly corrosive environments with the application of a silicone gel elastomer to sensor and ASIC. For questions concerning media compatibility, contact the factory.

## ORDERING INFORMATION

4525	-	DS	3	A	005	G	P	
<b>Model</b>	-	<b>Package Style</b>	<b>Supply Voltage</b>	<b>Output Type</b>	<b>Pressure Range (psi)</b>	<b>Pressure Type</b>	<b>Pin Style</b>	<b>Option Type</b>
<b>MS4525</b>	-	<b>SS</b> = Single Sideport <b>DS</b> = Dual Sideport <b>TP</b> = Top Port <b>MM</b> = Manifold Mount	<b>3</b> = 3.3 Vdc <b>5</b> = 5.0 Vdc	<b>A</b> = 10% to 90% <b>B</b> = 5% to 95%	<b>001</b> <b>002</b> <b>005</b> <b>015</b> <b>030</b> <b>050</b> <b>100</b> <b>150</b>	<b>A</b> = Absolute <b>D</b> = Differential <b>G</b> = Gage <b>C</b> = Compound <b>V</b> = Vacuum	<b>P</b> = Thru Hole <b>S</b> = J Lead <b>L</b> = In Line <b>C</b> = Castellation	<b>Blank</b> = No Option <b>F</b> = Gel Coating

## 联系方式



深圳市亿为测控电子有限公司  
Shenzhen Bill-Well Measurement & Control Electronics Co., Ltd.

地址：深圳市南山区创业路怡海广场东座 2408 邮编：518000

电话：(+86) 0755 2641 9890 传真：(+86) 0755 2641 9680

电子邮箱：sales@bill-well.com