

1230

UltraStable™

SPECIFICATIONS

- **PC Board Mountable Pressure Sensor**
- **0-100 mV Output**
- **Current Excitation**
- **Gage, Differential, and Absolute**
- **Temperature Compensated**

The 1230 is a high performance temperature compensated, piezoresistive silicon pressure sensor packaged in a dual-in-line configuration. It uses Measurement Specialties' proprietary UltraStable™ die to provide excellent performance and long-term stability over wide temperatures.

Integral temperature compensation is provided over a range of -20°C to +85°C using laser-trimmed resistors. An additional laser-trimmed resistor is included to normalize pressure sensitivity variations by programming the gain of an external differential amplifier. This provides sensitivity interchangeability of $\pm 1\%$. Absolute, differential and gage pressure ranges from 0-15 to 0-100 psi are available. Multiple lead and tube configurations are available for different applications.

Please refer to the 1210 and 1220 for information on products with operating pressures less than 0-15 psi. For voltage excitation, please refer to the Model 1240.

FEATURES

Dual-in-Line Package
 -20°C to +85°C Compensated
 Temperature Range
 ±0.1% Non Linearity
 1.0% Interchangeable Span
 (provided by gain set resistor)
 Solid State Reliability

APPLICATIONS

Medical Instruments
 Altitude Measurement
 Process Control
 Factory Automation
 Handheld Calibrators
 Environmental Control

STANDARD RANGES

Range	psia	psid	psig
0 to 2		•	•
0 to 5		•	•
0 to 15	•	•	•
0 to 30	•	•	•
0 to 50	•	•	•
0 to 100	•	•	•

PERFORMANCE SPECIFICATIONS

Supply Current: 1.5 mA

Ambient Temperature: 25°C (unless otherwise specified)

PARAMETERS	MIN	TYP	MAX	UNITS	NOTES
Span	75	100	150	mV	1
Zero Pressure Output	-2		2	mV	
Pressure Non Linearity	-0.1	±0.05	0.1	%Span	2
Pressure Hysteresis	-0.1	±0.01	0.1	%Span	
Input Resistance	2200	4000	5800	Ω	
Output Resistance		4200		Ω	
Temperature Error – Span	-0.5	±0.3	0.5	%Span	3
Temperature Error – Zero	-0.5	±0.1	0.5	%Span	3
Temperature Coefficient – Resistance		0.15		%/°C	3
Thermal Hysteresis – Zero		±0.05		%Span	3
Short Term Stability (Offset & Span)		±0.05		%Span	4
Long Term Stability (Offset & Span)		±0.1		%Span	5
Supply Current	0.5	1.5	2.0	mA	
Response Time (10% to 90%)		1.0		mS	6
Output Noise (10Hz to 1kHz)		1.0		μV p-p	
Pressure Overload			3X	Rated	7
Compensated Temperature	-20		+85	°C	
Operating Temperature	-40		+125	°C	
Storage Temperature	-50		+150	°C	
Weight			3	grams	
Solder Temperature	250°C Max 5 Sec.				
Media	Non-Corrosive Dry Gases Compatible with Silicon, Pyrex, RTV, Gold, Ceramic, Nickel, and Aluminum				

Notes

1. Ratiometric to supply current. Span for 2PSI is 30 to 60mV.
2. Best fit straight line. Non Linearity for 2 PSI is ±0.2% and 5 PSI is ± 0.5%.
3. Maximum temperature error between -20°C and +85°C with respect to 25°C.
4. Short term stability over 7 days with constant current and temperature.
5. Long term stability over a one year period with constant current and temperature.
6. For a zero-to-full scale pressure step change.
7. 2X maximum for 100 psi device.

DIMENSIONS

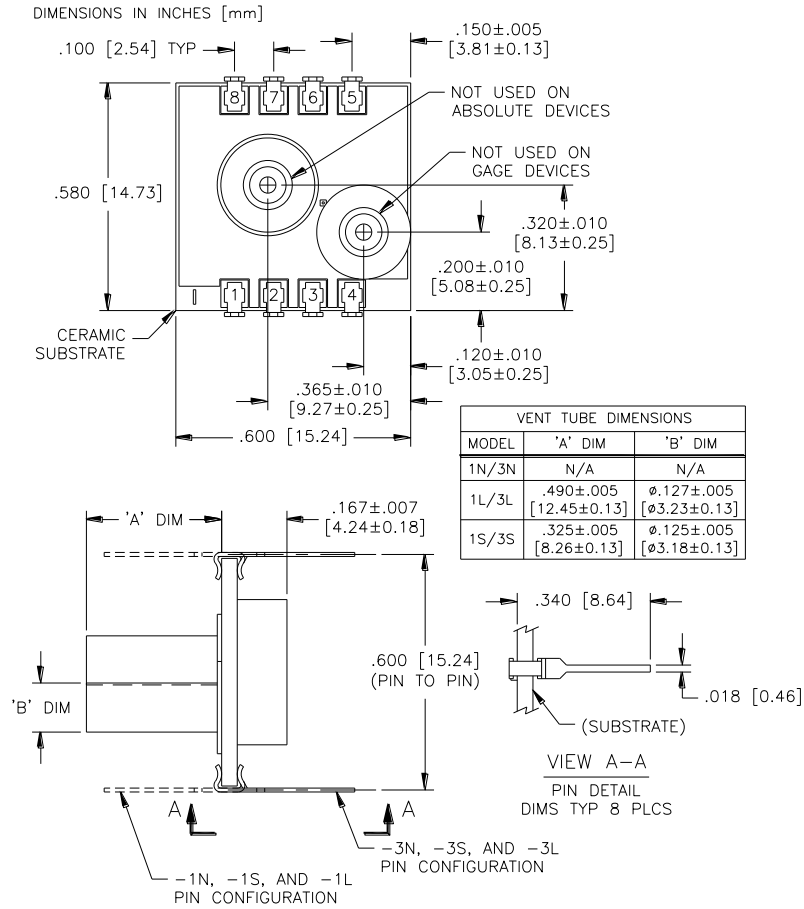

CONNECTIONS

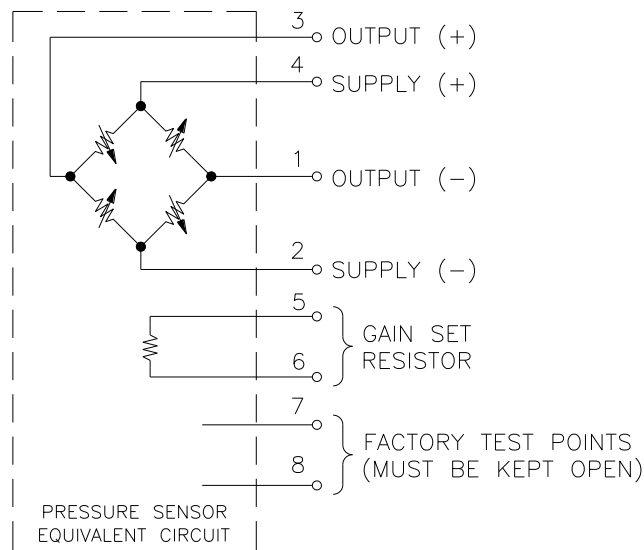

APPLICATION SCHEMATIC

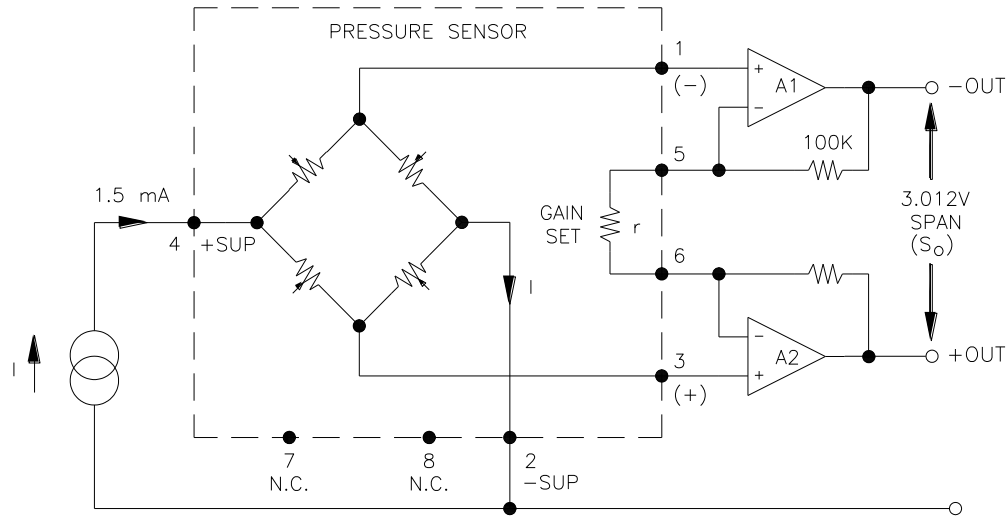

APPLICATION SCHEMATIC

ORDERING INFORMATION

1230 - 015 G - 3 S

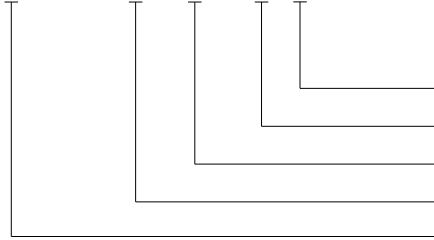

- Pressure Tubes (L = Long, S = Short, N = None)
- Lead Configuration (1,3 - See Dimensions Diagram)
- Type (G= Gage, A = Absolute, D = Differential)
- Pressure Range
- Model

联系方式



深圳市亿为测控电子有限公司
Shenzhen Bill-Well Measurement & Control Electronics Co., Ltd.

地址：深圳市南山区创业路怡海广场东座 2408 邮编：518000
电话：(+86) 0755 2641 9890 传真：(+86) 0755 2641 9680
电子邮箱：sales@bill-well.com