

1210

1psi

SPECIFICATIONS

- **PC Board Mountable Pressure Sensor**
- **0-100 mV Output**
- **Current Excitation**
- **Gage and Differential**
- **Temperature Compensated**

The 1210 1psi is a temperature compensated, piezoresistive silicon pressure sensor packaged in a dual-in-line configuration. It is intended for cost sensitive applications where excellent performance and long-term stability are required.

Integral temperature compensation is provided over a range of 0-50°C using laser-trimmed resistors. An additional laser-trimmed resistor is included to normalize pressure sensitivity variations by programming the gain of an external differential amplifier. This provides sensitivity interchangeability of $\pm 1\%$.

Please refer to the 1210 standard datasheet for information on products with operating pressures greater than 1psi. For voltage excitation, please refer to the Model 1220.

FEATURES

- Dual-in-Line Package
- 1.0% Interchangeable Span
(provided by gain set resistor)
- $\pm 0.3\%$ Non Linearity
- Solid State Reliability

APPLICATIONS

- Medical Instruments
- Airspeed Measurement
- Process Control
- Factory Automation
- Leak Detection

STANDARD RANGES

Range	psid	psig	Port Styles
0 to 1	•	•	S, L, N, B*

*Barb port styles are only available in lead configuration type 3. See Ordering Information.

PERFORMANCE SPECIFICATIONS

Supply Current: 1.5 mA

Ambient Temperature: 25°C (unless otherwise specified)

PARAMETERS	PRESSURE RANGE 0 – 1 psi			UNITS	NOTES
	MIN	TYP	MAX		
Full Scale Output Span	50	100	150	mV	1
Zero Pressure Output (Offset)	-2.0		2.0	mV	
Pressure Non Linearity	-0.3		0.3	%Span	2
Pressure Hysteresis	-0.1	±0.01	0.1	%Span	
Input/Output Resistance	1800		6500	Ω	
Temperature Error – Span	-1.0	±0.5	1.0	%Span	3
Temperature Error – Zero	-1.0	±0.5	1.0	%Span	3
Thermal Hysteresis – Zero		±0.1		%Span	3
Long Term Stability (Offset & Span)		±0.2		%Span/year	
Supply Current	0.5	1.5	2.0	mA	4
Response Time (10% to 90%)		1.0		mSec	5
Output Noise		1.0		μV p-p	6
Output Load Resistance	2			MΩ	7
Insulation Resistance (50Vdc)	50			MΩ	
Pressure Overload			10	psi	
Operating Temperature	-40		+125	°C	
Storage Temperature	-50		+150	°C	
Media	Non-Corrosive Dry Gases Compatible with wetted materials				8
Weight	3 grams				

Notes

1. Output span of unamplified sensor.
2. Best fit straight line.
3. Temperature range: 0°C to 50°C with reference to 25°C.
4. Guarantees input/output ratiometricity for span.
5. For a zero-to-full scale pressure step change.
6. 10Hz to 1kHz.
7. Prevents increase of TC-Span due to output loading.

Wetted materials: glass, ceramic, silicon, fluorosilicone, nickel, gold and aluminum

Additional Notes

Soldering leads pins: 250°C for 5 seconds, maximum.

DIMENSIONS (TUBE VERSION)

DIMENSIONS IN INCHES [mm]

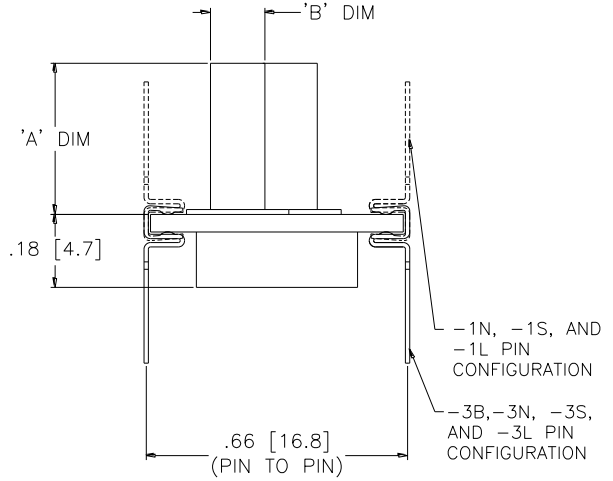
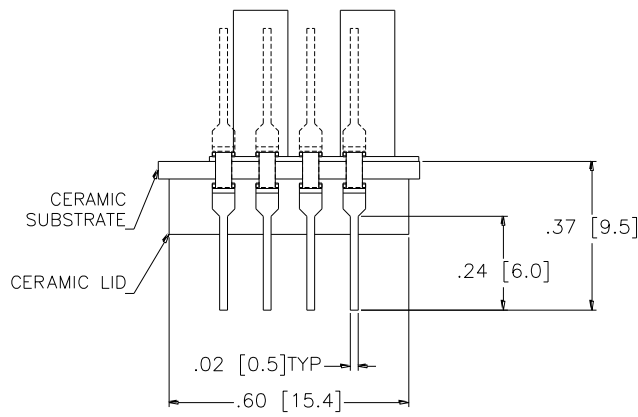
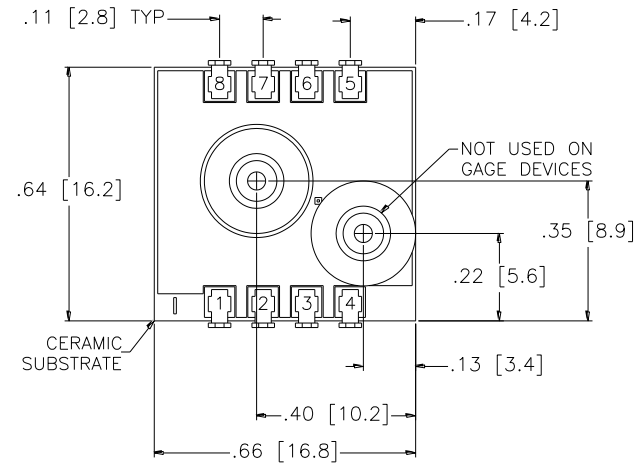

VENT TUBE DIMENSIONS		
MODEL	'A' DIM	'B' DIM
1N/3N	N/A	N/A
1L/3L	.490±.005 [12.45±0.13]	∅.127±.005 [∅3.23±0.13]
1S/3S	.325±.005 [8.26±0.13]	∅.125±.005 [∅3.18±0.13]

PAD NO	FUNCTION
1	-OUT
2	-EX
3	+OUT
4	+EX
5,6	GAIN
7,8	TEST

DIMENSIONS (BARB VERSION)

DIMENSIONS IN INCHES [mm]

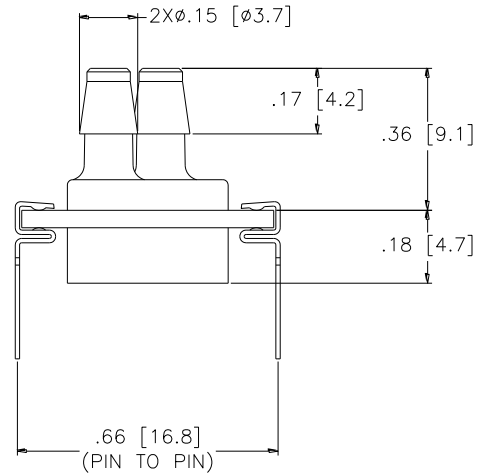
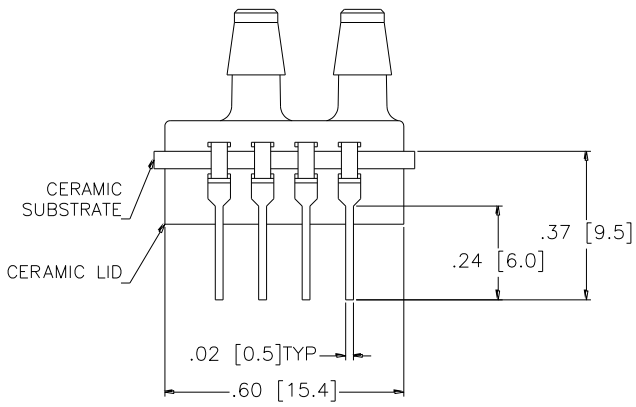
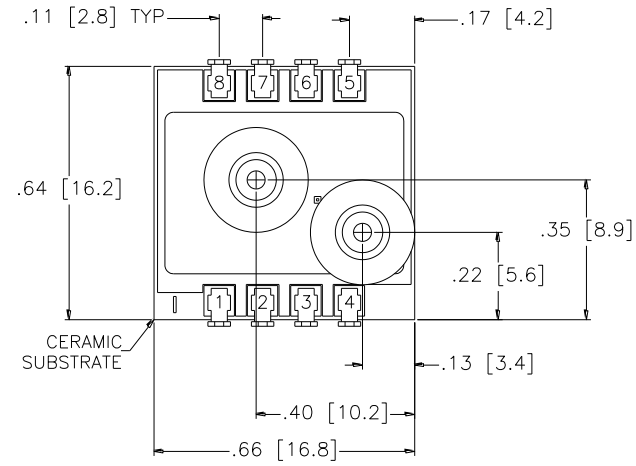

PAD NO	FUNCTION
1	-OUT
2	-EX
3	+OUT
4	+EX
5,6	GAIN
7,8	TEST

CONNECTIONS

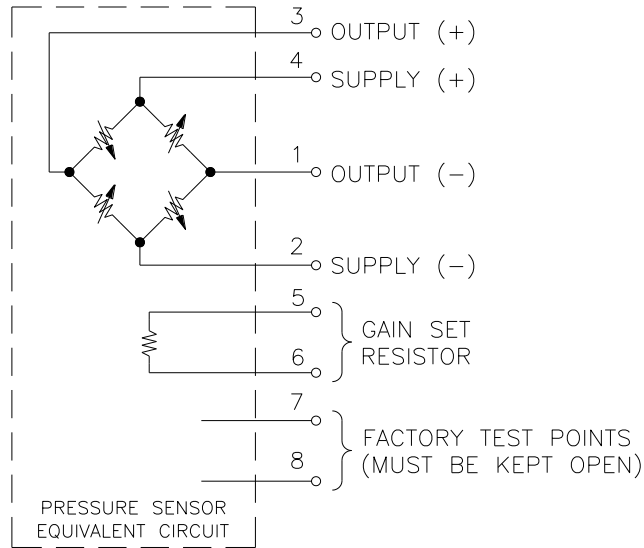

APPLICATION SCHEMATIC

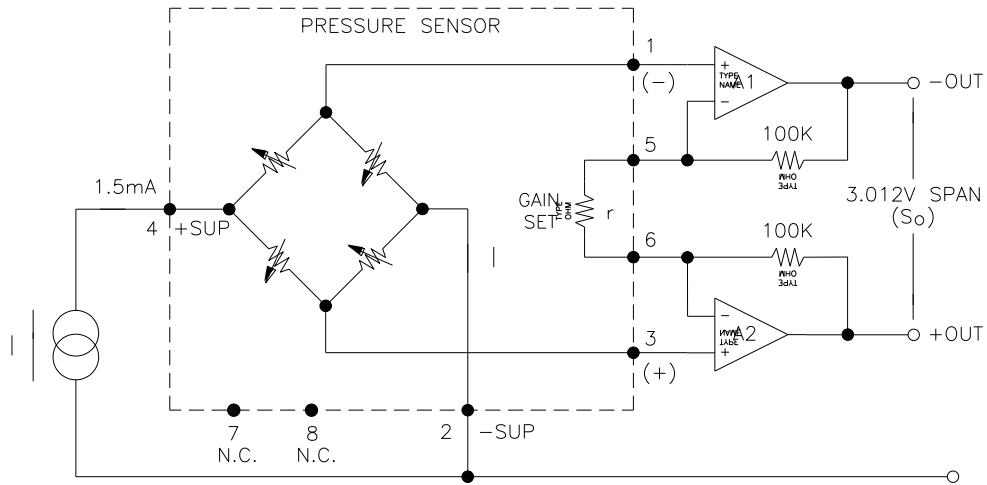

ORDERING INFORMATION

1210A - 001 G - 3 S

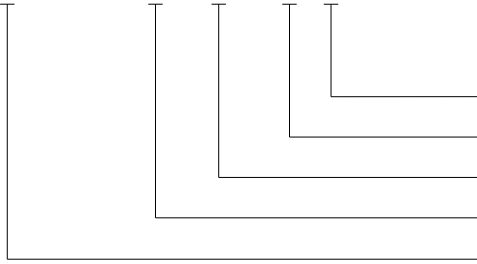

Vent (L = Long, S = Short, N = None, B = Barb)

Lead Configuration (1 = Same side as vent, 3 = Opposite side as vent)

Type (G= Gage, D = Differential)

Pressure Range

Model

*Barb vent port style only available in lead configuration type 3.

联系方式



深圳市亿为测控电子有限公司
Shenzhen Bill-Well Measurement & Control Electronics Co., Ltd.

地址：深圳市南山区创业路怡海广场东座 2408 邮编：518000

电话：(+86) 0755 2641 9890 传真：(+86) 0755 2641 9680

电子邮箱：sales@bill-well.com