

1210

Standard

SPECIFICATIONS

- **PC Board Mountable Pressure Sensor**
- **0-100 mV Output**
- **Current Excitation**
- **Gage, Absolute, and Differential**
- **Temperature Compensated**

The 1210 is a temperature compensated, piezoresistive silicon pressure sensor packaged in a dual-in-line configuration. It is intended for cost sensitive applications where excellent performance and long-term stability are required.

Integral temperature compensation is provided over a range of 0-50°C using laser-trimmed resistors. An additional laser-trimmed resistor is included to normalize pressure sensitivity variations by programming the gain of an external differential amplifier. This provides sensitivity interchangeability of $\pm 1\%$. Gage, absolute, and differential pressure ranges from 0-2 psi to 0-100 psi are available. Multiple lead and tube configurations are available for specific applications.

Please refer to the 1210 1 psi datasheet for low pressure applications. For voltage excitation, please refer to the Model 1220.

FEATURES

- Dual-in-Line Package
- 0°C to 50°C Compensated Temperature Range
- ±0.1% Non Linearity
- 1.0% Interchangeable Span (provided by gain set resistor)
- Solid State Reliability

APPLICATIONS

- Medical Instruments
- Airspeed and Altitude Measurements
- Process Control
- Factory Automation
- Vacuum Measurement
- Handheld Calibrators

STANDARD RANGES

Range	psia	psid	psig	Port Styles
0 to 2		•	•	S, L, N, B*
0 to 5	•	•	•	S, L, N, B*
0 to 15	•	•	•	S, L, N
0 to 30	•	•	•	S, L, N,
0 to 50	•	•	•	S, L, N
0 to 100	•	•	•	S, L, N

*Barb port styles are only available in lead configuration type 3. See Ordering Information.

PERFORMANCE SPECIFICATIONS

Supply Current: 1.5mA

Ambient Temperature: 25°C (unless otherwise specified)

PARAMETERS	MIN	TYP	MAX	UNITS	NOTES
Span	75	100	150	mV	1
Span (2 psi version)	30		60	mV	1
Zero Pressure Output	-2		2	mV	
Pressure Non Linearity	-0.1	±0.05	0.1	%Span	2
Pressure Hysteresis	-0.05	±0.01	0.05	%Span	
Input & Output Resistance	2500	4400	6000	Ω	
Temperature Error – Span	-0.5	±0.3	0.5	%Span	3
Temperature Error – Zero	-0.5	±0.1	0.5	%Span	3
Thermal Hysteresis – Zero		±0.1		%Span	3
Supply Current		1.5	2.0	mA	
Response Time (10% to 90%)		1.0		mS	4
Output Noise (10Hz to 1kHz)		1.0		μV p-p	
Long Term Stability (Offset & Span)		±0.1		%Span	5
Pressure Overload			3X	Rated	6
Compensated Temperature	0		50	°C	
Operating Temperature	-40		+125	°C	
Storage Temperature	-50		+150	°C	
Weight			3	grams	
Solder Temperature	250°C Max 5 Sec.				
Media	Non-Corrosive Dry Gases Compatible with Silicon, Pyrex, RTV, Gold, Ceramic, Nickel, and Aluminum				

Notes

1. Ratiometric to supply current.
2. Best fit straight line.
3. Maximum temperature error between 0°C and 50°C with respect to 25°C. For 2psi devices, Temperature Error -- Zero is ±1%.
4. For a zero-to-full scale pressure step change.
5. Long term stability over a one year period with constant current and temperature.
6. 2X maximum for 100psi device. 20psi maximum for 2 and 5psi devices.

DIMENSIONS

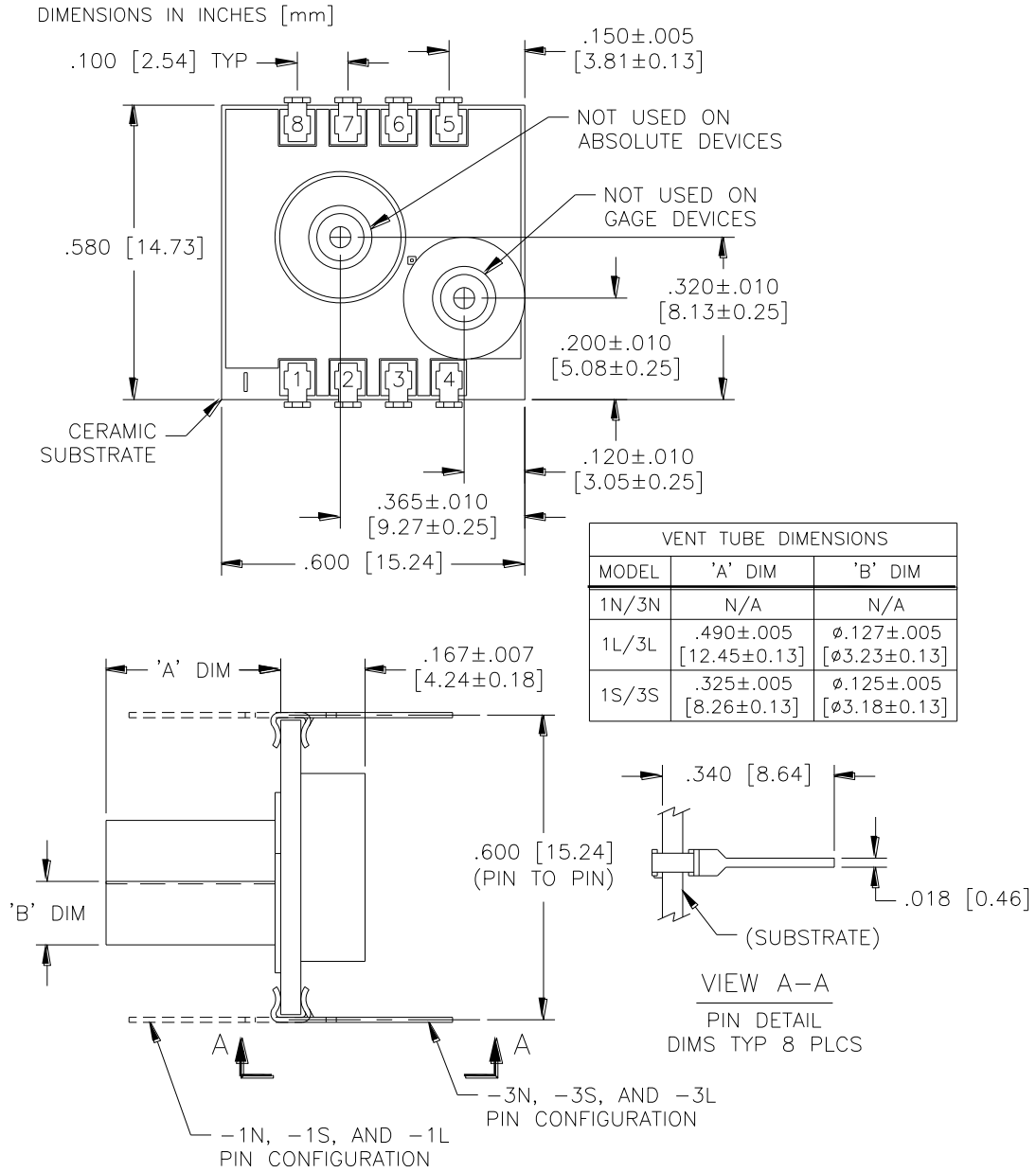

BARB DIMENSIONS

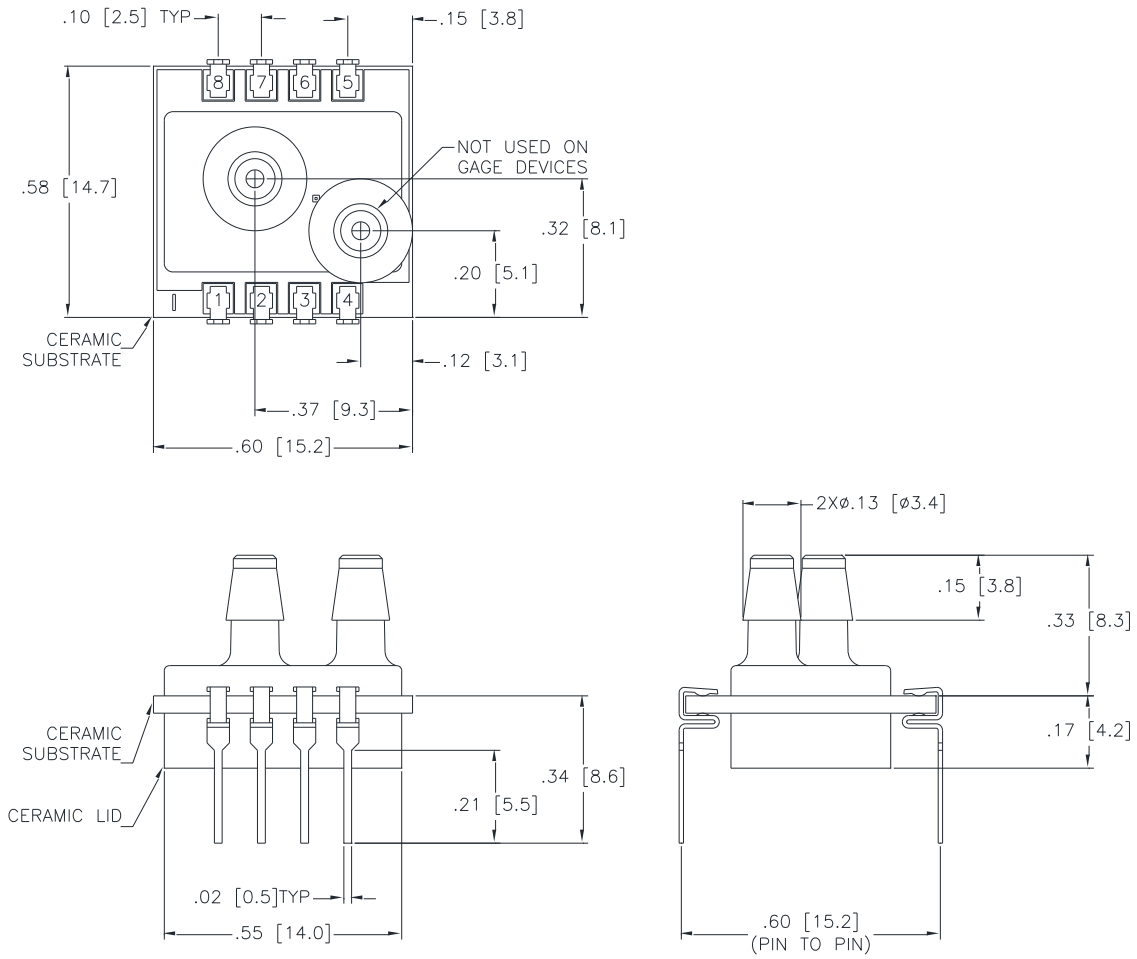

CONNECTIONS

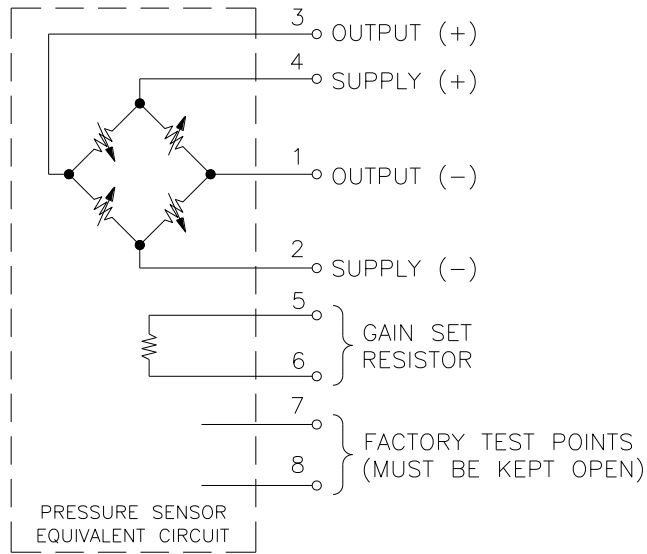

APPLICATION SCHEMATIC

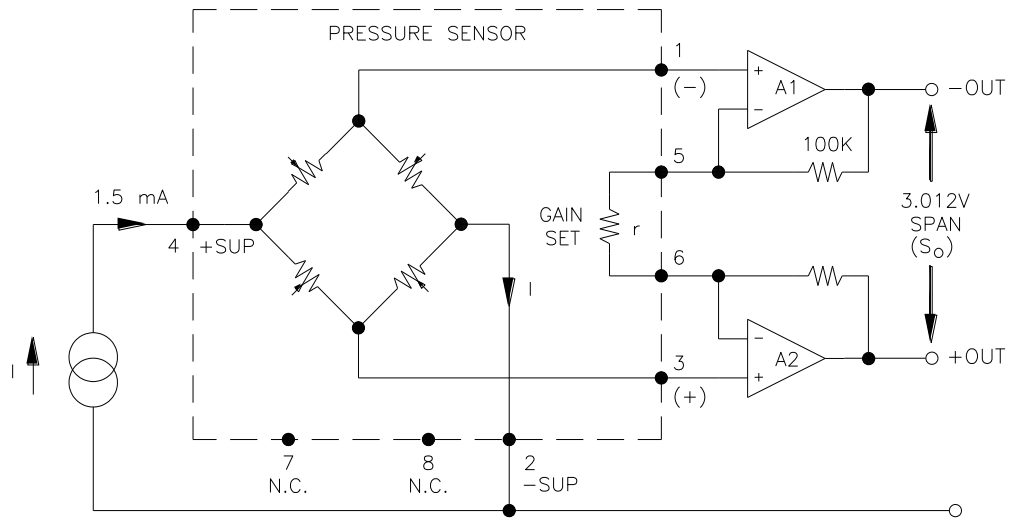

APPLICATION SCHEMATIC

