



## PRESSURE LOW

### Differential Transmitter AST5100

#### Overview

The AST5100 Wet - Wet Differential Pressure transmitter is your accurate pressure sensing device for low differential pressure. With a differential pressure range as low as 0 to 5" water column (12.5mbar), this product can be used to measure flow across an orifice, differential across a filter, tank level, or gauge pressure. Using LVDT technology and AST's advanced electronics, the AST5100 delivers accurate, repeatable measurements.

#### Benefits

- Accurate Low Pressure Measurement
- Excellent Repeatability
- Wide Range of Liquids and Gases including:
  - ✓ Water
  - ✓ Natural Gas
  - ✓ Hydrocarbon Fuels
  - ✓ Air
  - ✓ Non-Corrosive Gases

## LOW

### AST5100 Low Pressure Differential Transmitter

---

#### Applications

- Liquid Level Control including Bubbler systems
- Climate Control
- Energy Management
- Air-fuel Ratio including Measurement for Furnaces
- Vapor Recovery
- Leak Detection
- Air or liquid Filtration
- Flow Measurement

#### Wetted Materials

- Nickel Alloy 52, Ni-Span C, Viton, 304 Stainless Steel, Aluminum 6061, RoHS Solder, Loctite 680 (meets NSF61)

#### Installation Guidelines

The AST5100 must be mounted on a flat surface within  $\pm 15^\circ$  to the ideal  $0^\circ$  plane to maintain specifications. Do not over tighten the pressure connections or insert any objects in P1 or P2 to avoid damaging the sensing element. When using isolation valves, both should be mounted close to the sensor. For liquid level and wet applications, install bleed screw adapters close to P1 and P2 so that trapped air can be purged if needed. For optimum performance, always make sure pressure is equalized within the pressure range chart ranges. The AST5100 has asymmetric protection on P1 and P2.

#### Performance @ 25°C (77°F)

<b>Accuracy</b>	< $\pm 1.0\%$ FS (Accuracy includes non-linearity, hysteresis & non-repeatability)
<b>Stability (1 year)</b>	$\pm 0.5\%$ FS, typical
<b>Burst Pressure</b>	2000 PSI
<b>Pressure Cycles</b>	> 100,000 Cycles

#### Environmental Data

##### Temperature

<b>Operating</b>	-40 to 80°C (-40 to 176°F)
<b>Storage</b>	-40 to 100°C (-40 to 212°F)

0-100% relative humidity, non-condensing

##### Thermal Limits

**Compensated Range** 0 to 55°C (32 to 131°F)

<b>TC Zero</b>	< $\pm 1.5\%$ of FS
<b>TC Span</b>	< $\pm 1.5\%$ of FS

## LOW

### AST5100 Low Pressure Differential Transmitter

#### Electrical Data

<b>Output</b>	4-20mA	0-5V Three Wire
<b>Excitation</b>	10-28VDC	10-28VDC
<b>Output Impedance with Input Voltage Change</b>	-	< 0.1% from 10 to 32 VDC
<b>Current Consumption:</b>	-	< 10mA
<b>Bandwidth</b>	5Hz	5Hz
<b>Output Noise</b>	< 0.0035mA, RMS	< 1mV RMS
<b>Zero Offset:</b>	< ±1% FS	< ±1% FS
<b>Span Tolerance:</b>	< ±1.5% FS	< ±1.5% FS
<b>Output Load:</b>	0-800 Ohms@10-28 VDC	5k Ohms, Min.
<b>Reverse Polarity</b>	Yes	Yes

#### Dimensions

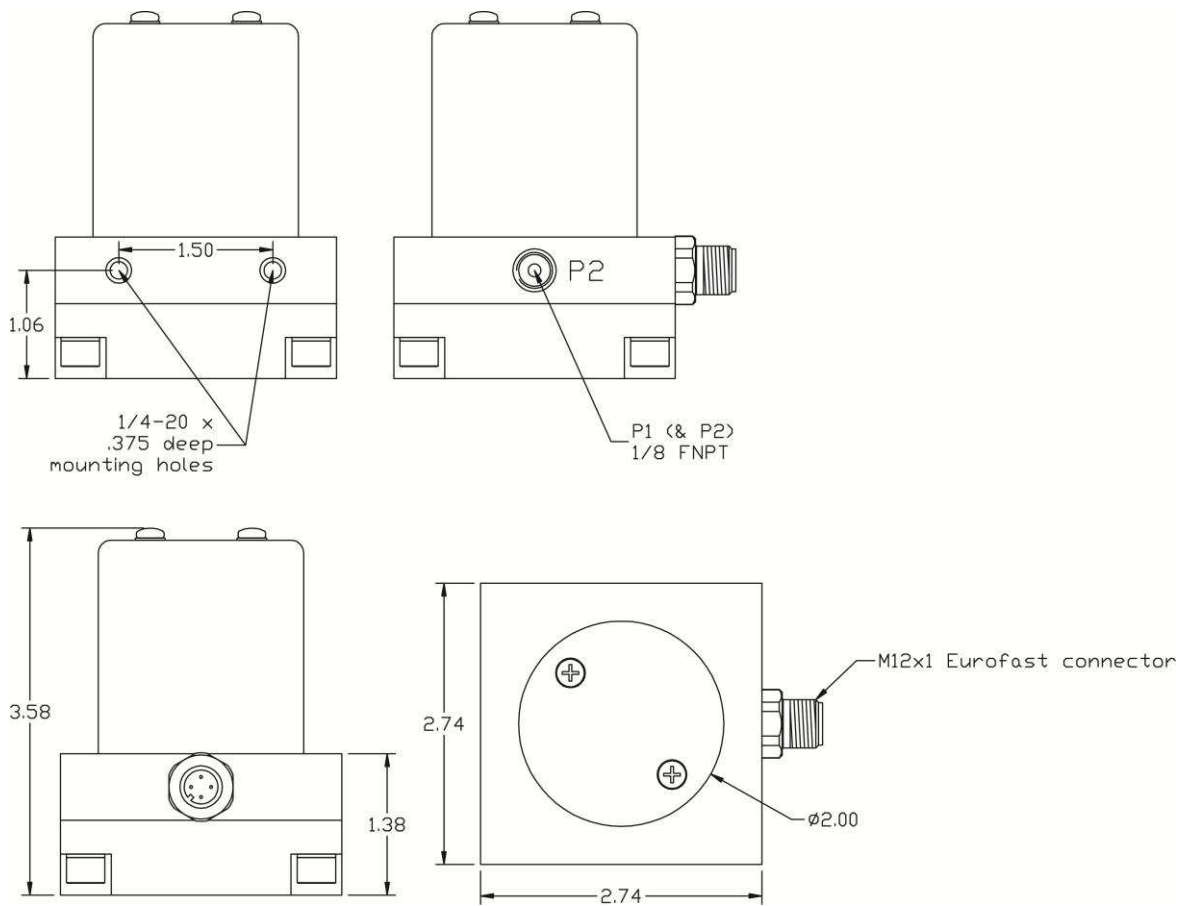

# LOW

## AST5100 Low Pressure Differential Transmitter

### Ordering Information

AST5100 J 00050 H 4 Y 5 000

#### Series Type

#### Process Connection

J= 1/8" NPT Female

#### Pressure Range

See Chart

#### Pressure Unit

H= Inches H<sub>2</sub>O  
P= PSI

#### Outputs

2= 0-5V 3-wire  
4= 4-20mA (2 wire loop powered)

#### Electrical

Y= M12x1

#### Wetted Material

5= Nickel Alloy 52, Ni-Span C, Viton, 304 Stainless Steel,  
Aluminum 6061, RoHSSolder, Loctite 680 (meets NSF61)

#### Options

000= No Special Options

#### Pressure Ranges

Differential Pressure	Pressure Code	Proof Pressure (P1>P2)	Proof Pressure (P2>P1)
0-5 inch H <sub>2</sub> O (12.5 mbar)	00005H	5 PSI	3 PSI
0-10 inch H <sub>2</sub> O (25 mbar)	00010H	5 PSI	3 PSI
0-20 inch H <sub>2</sub> O (50 mbar)	00020H	8 PSI	5 PSI
0-50 inch H <sub>2</sub> O (125.5 mbar)	00050H	15 PSI	10 PSI
0-100 inch H <sub>2</sub> O (249 mbar)	00100H	35 PSI	25 PSI
0-200 inch H <sub>2</sub> O (498 mbar)	00200H	35 PSI	25 PSI
0-15 PSID (1034 mbar)	00015P	75 PSI	50 PSI

Mating PUR 22 AWG Cable Assembly	
Part Number	Cable Length
A10089	4 feet (1 m)
A10090	10 feet (3 m)

Pins	Conductor Colors	0-5V 3-wire	4-20mA
Pin 1	Brown	+V	+V
Pin 2	White	N/C	N/C
Pin 3	Blue	-V	-V
Pin 4	Black	V Out	N/C

The over-pressure specification is the maximum pressure the AST5100 can see without damage. Any pressure applied over the listed numbers will likely damage the sensor and will, at minimum, cause a permanent zero shift. Over-pressure between 2X span and the numbers listed applied to port P1 will likely cause no permanent harm. Over-pressure of between 2X span and the numbers listed applied to port P2 may cause a temporary zero shift. To recover from a zero shift caused by negative over-pressure to P2 within the listed limits, apply a positive over-pressure P1 to just under the listed limit for a duration of 5 minutes. Remove the over-pressure and check the zero with no pressure applied. If the zero has not recovered, repeat the positive over-pressure and recheck zero. If it has not recovered after the second try, the zero has been permanently shifted. Contact the factory.

## 联系方式



**深圳市亿为测控电子有限公司**  
Shenzhen Bill-Well Measurement & Control Electronics Co., Ltd.

地址：深圳市南山区创业路怡海广场东座 2408 邮编：518000

电话：(+86) 0755 2641 9890 传真：(+86) 0755 2641 9680

电子邮箱：sales@bill-well.com