

- High/low liquid level monitor
- “Peel and stick” to the outside of a wide range of plastic containers
- Never comes in contact with liquid – no risk of contamination or volume displacement
- Proven ultrasonic technology
- Repeatability:  $\pm 0.1$ ” (2.54 mm)

## DESCRIPTION

The Non-Invasive Sonic Eye™ is a cost effective ultrasonic sensor for plastic containers. The sensor is designed to adhere to the outside of plastic containers of various sizes from 2” (50.8mm) to 10” (254mm) with a wall thickness up to 0.25” (6.35mm) as a high/low level liquid level monitor. The sensor sticks to the outside of the container, never coming in contact with the liquid, so there is no contamination or volume displacement.

## FEATURES

### Standard Features

- Non-invasive miniature sensor designed to stick to outside of container
- Integral electronics with disposable mounting
- Effective on plastic bottles with diameters ranging from 2” (50.8 mm) to 10” (254 mm)
- Independent of color, transparency, shape and size of bottom of container
- No displacement of liquid volume
- Eliminates fluid contamination problem
- No calibration required

### Optional Features

- 3.3 volt input power
- Relay output
- 1” diameter containers & glass/metal containers

## APPLICATIONS

- Chemical Analyzer
- Immuno Chemistry
- Chromatography
- Kidney Dialysis
- Clinical Chemistry
- Medical Laser System
- Hemodialysis
- Semiconductor
- Waste Management

# SL-630 Series

## PERFORMANCE SPECIFICATIONS

Parameter	Typical Value	Parameter	Typical Value
Repeatability	± 0.1" (2.54 mm)	Protection	Transient, reverse polarity
Response Time	200 milliseconds (for special response times consult factory)	Effective Plastic Bottle Diameter	2" (50.8 mm) to 10" (254 mm)
Input Power	5 to 24 VDC	Wall Thickness	Up to 0.25" (6.35 mm)
Leakage Current	Less than 50 µA	Sensor Material	ULTEM® (plastic)
Output	TTL (high) – dry condition	Temperature	-20 to 158 °F (30 to 70 °C)
Mounting	Reusable sensor/disposable mounting tape	Cable Length	12" (305 mm) (for longer lengths consult factory)

## MECHANICAL DIMENSIONS in inches

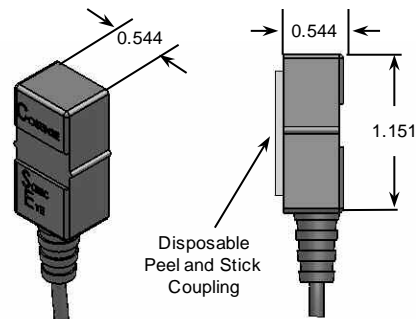

Figure 1: SL-630 series element with peel and stick disposable mounting tape.

NOTES: Clean area on container before installing. Remove backing from tape and adhere to container. Press sensor to container firmly.

## WIRING DIAGRAM

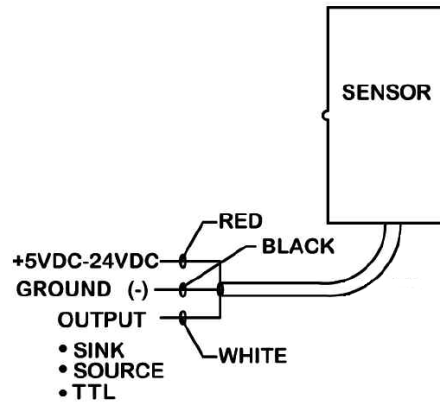

Figure 3: Wiring diagram for SL-630 series elements.

## ORDERING INFORMATION

# SL-630 Series

Input	Output	Part Number
5 VDC – 24 VDC	TTL*	SL630-C01

\*Custom outputs available. Consult factory for details.

## 联系方式



深圳市亿为测控电子有限公司  
Shenzhen Bill-Well Measurement & Control Electronics Co., Ltd.

广东省深圳市南山区创业路怡海广场东座2407 邮编：518000

电话：+86 755 2641 9890 传真：+86 755 2641 9680

电子邮箱：sales@bill-well.com