



- Contact less Temperature Measurement
- Small Size
- Heat Spreader improves Accuracy
- Wide Supply Voltage Range
- Digital Interface Bus (SPI)
- Connector
- Small Field of View
- Improved constancy of output signal over distance

## DESCRIPTION

The TSEV01S01C05 is a contact-less temperature measuring system for OEM use based on the detection of infrared radiation.

The TSEV01S01C05 is equipped with an infrared sensor (Thermopile) in front. The Thermopile Sensor has to be pointed at the target object.

The basic working principle is:

- Detection of infrared radiation with a Thermopile sensor, which turns incoming radiation to an analogue voltage
- Determination of sensor temperature using a thermistor
- Calculation of ambient and object temperature using a processing unit
- Providing the ambient and objects temperature at digital output bus (SPI)

The thermopile sensor module is suitable for a wide range of application where non-contact temperature measurement and high accuracy are required.

## FEATURES

0°C – 300°C Measurement Range  
Small Size  
Up to 2°C Accuracy  
2mA Current Consumption  
Improved constancy of output signal over distance

## APPLICATIONS

Contact less Temperature Measurement  
Climate Control  
Industrial Process Control  
Household Applications

# TSEV01S01C05

## ABSOLUTE MAXIMUM RATINGS

Absolute maximum ratings are limiting values of permitted operation and should never be exceeded under the worst possible conditions either initially or consequently. If exceeded by even the smallest amount, instantaneous catastrophic failure can occur. And even if the device continues to operate satisfactorily, its life may be considerably shortened.

Parameter	Symbol	Conditions	Min	Typ	Max	Unit
Supply Voltage	Vccmax	Stabilized supply voltage	-0.3		+16	V
Operating Temperature	Topmax		-10		+85	°C
Storage temperature	Tstor		-40		+85	°C
Humidity	HumL	-40°C - +50°C			85	%
Humidity	HumH	+50°C - +85°C			50	%

## OPERATING CONDITIONS

Parameter	Symbol	Conditions	Min	Typ	Max	Unit
Supply Voltage	Vcc	Stabilized supply voltage	+3.3		+16	V
Operating Temperature Range	Top		-10		+85	°C
Emission Coefficient	$\epsilon$		0.98			

## SENSOR CONDITIONS

Parameter	Symbol	Conditions	Min	Typ	Max	Unit
Field of View	FOV 10	Total field of view at 10% signal level		8		°
Field of View	FOV 50	Total field of view at 50% signal level		5		°
Wavelength Range	S		Silicon, no coating			$\mu\text{m}$

## OPERATIONAL CHARACTERISTICS

If not otherwise noted, 5V supply voltage and object with  $\epsilon = 0.98$  were applied.

Parameter	Symbol	Conditions	Min	Typ	Max	Unit
Object Temperature Range	Tobj		0		300	°C
Resolution	Res				0.1	°C
Supply Current <sup>1)</sup>	I	No output load		2		mA
Data Output Rate	Fout			1		Hz
Standard Start-Up Time	tStart				3	s

## TOLERANCES

If not otherwise noted, 5V supply voltage and object with  $\epsilon = 0.98$  were applied.

Parameter	Symbol	Sensor Temp.	Object Temp.	Max	Unit
Standard Temp <sup>1)3)</sup>	AccS	$15 < T_{\text{sen}} < 35$	$160 < T_{\text{obj}} < 200$	2	°C
Extended Temp. 1 <sup>2)3)</sup>	AccE1	$T_{\text{sen}} < 15, T_{\text{sen}} > 35$	$160 < T_{\text{obj}} < 200$	3	°C
Extended Temp. 2 <sup>2)3)</sup>	AccE2	$15 < T_{\text{sen}} < 35$	$T_{\text{obj}} < 160, T_{\text{obj}} > 200$	3	°C
Extended Temp. 3 <sup>2)3)</sup>	AccE3	$T_{\text{sen}} < 15, T_{\text{sen}} > 35$	$T_{\text{obj}} < 160, T_{\text{obj}} > 200$	4	°C

**OTHER TEMPERATURE RANGES AND ACCURACIES ARE AVAILABLE ON REQUEST.**

<sup>1)</sup> Proved while production

<sup>2)</sup> Proved by design

<sup>3)</sup> Valid for a distance of 100mm and black body size of 150mm x 150mm

# TSEV01S01C05

## SENSOR FIELD OF VIEW

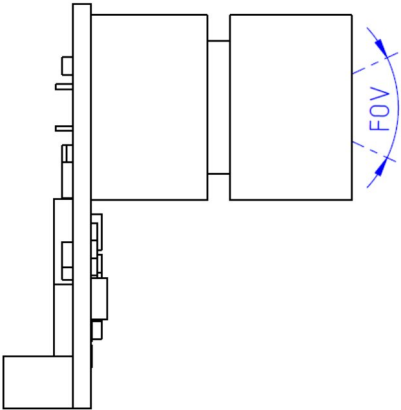
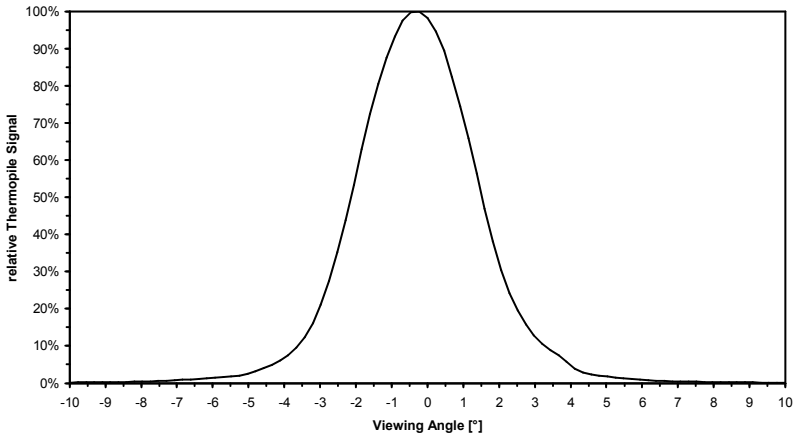

## MECHANICAL DIMENSIONS

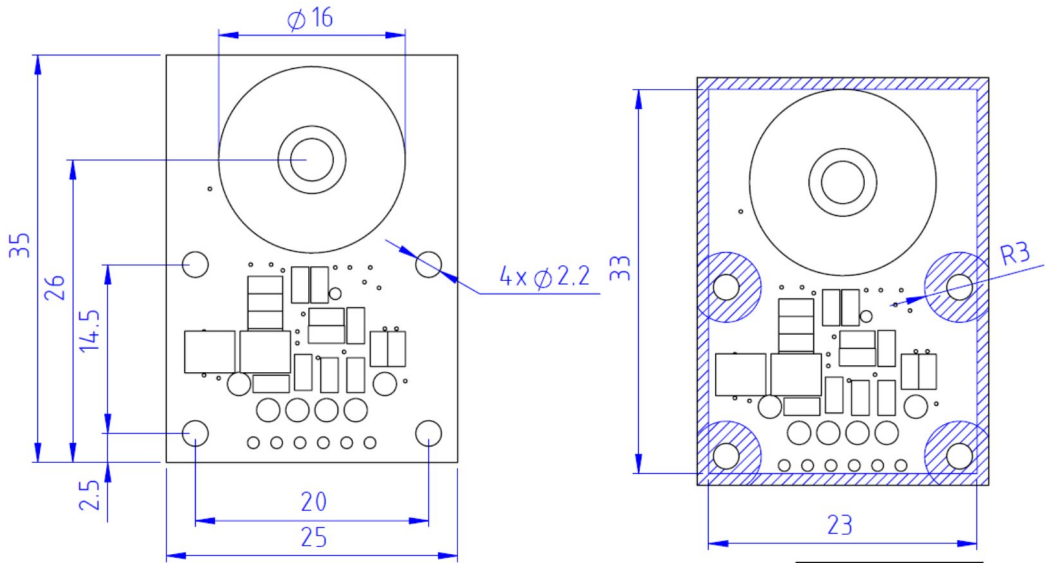

Only use hatched areas for mechanical assembly (screws, nuts, etc).

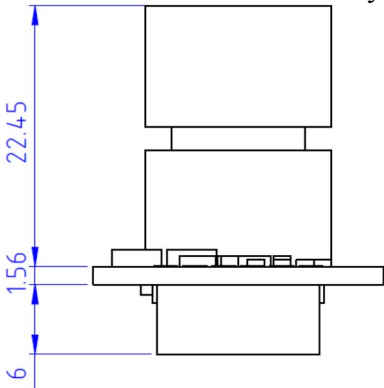

# TSEV01S01C05

## TERMINALS

Connector: JST PHR-6

Pin	Name	Description	Type
1	VDD	Supply Voltage	Supply
2	GND	Ground	Supply
3	SCL	SPI Clock	Interface
4	MISO	SPI Master In /	Interface
5	MOSI	SPI Master Out /	Interface
6	SCE	SPI Chip Enable	Interface

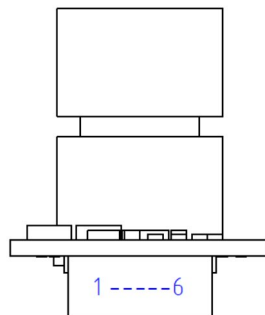

## BLOCK DIAGRAM

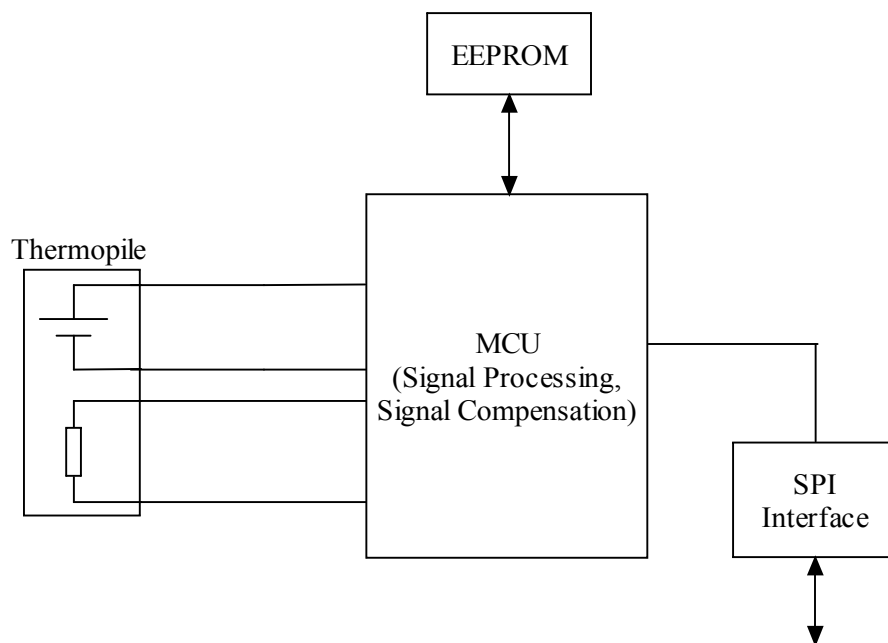

# TSEV01S01C05

## INTERFACE

### PARAMETER

Parameter	Symbol	Conditions	Min	Typ	Max	Unit
Baudrate	FSPi		10		100	kHz
Data Bits				8		
Chip Select				Yes		
Input Voltage Low					0.9	V
Input Voltage High		Vcc = 3.3V	2.1			V
Output Voltage Low		1mA			0.3	V
Output Voltage High		Vcc = 3.3V, 1mA	3.0			V

### SIGNAL DESCRIPTION

- SCE (Chip Select)            0 = Enable, 1 = Disable
- CKP                            0
- CKE                            1

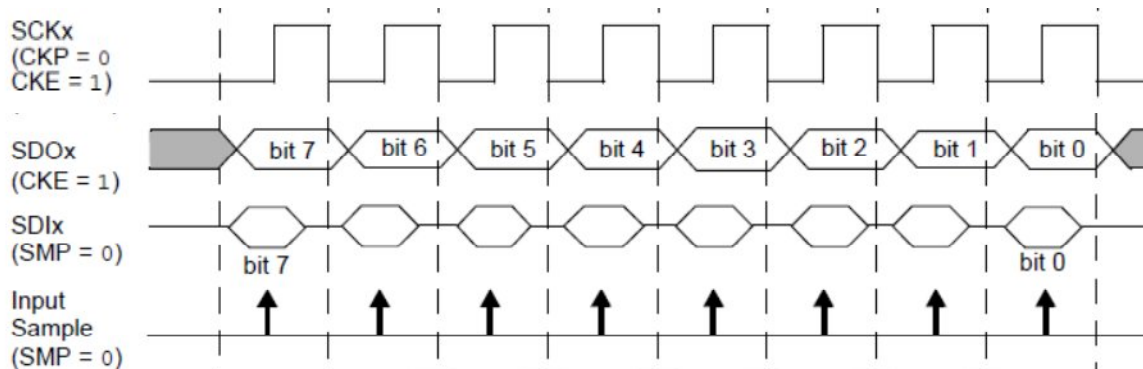

### SAMPLE CODE

Sample Code for sending 8 bits and reading 8 bits while sending 8 clocks.

```
// Setting directions
TRISC4 = 1; // SDI = Input
TRISC5 = 0; // SDO = Output
TRISC3 = 0; // SCL = Output

// Reset SPI Lines
RC5 = 0; // SDO
RC3 = 0; // SCL

for (c = 0; c < 8; c++)
{
    cReceive = cReceive << 1; // Shift Receive Register
    RC3 = 0; // SCL = 0
    RC5 = (cTransmit >> (7 - c)); // Output next Bit on SDO
    RC3 = 1; // SCL = 1
    cReceive = cReceive | RC4; // Input next Bit on SDI
}

RC3 = 0;
RC5 = 0;

return cReceive;
```

# TSEV01S01C05

## AMBIENT AND OBJECT TEMPERATURE MEASUREMENT

Please refer following table for SPI commands to read object temperature and ambient temperature. Both values are transmitted in hundredth of degrees.

Com	Description	Reply	Bytes
0xA0	Sensor Temperature	Sensor temperature in hundredth of degrees Celsius	2
0xA1	Object Temperature	Object temperature in hundredth of degrees Celsius	2

## SEQUENCE OF TRANSMISSION

Enable SCE (SCE=0) before transmission of "Command". Release SCE (SCE=1) after reading last byte.

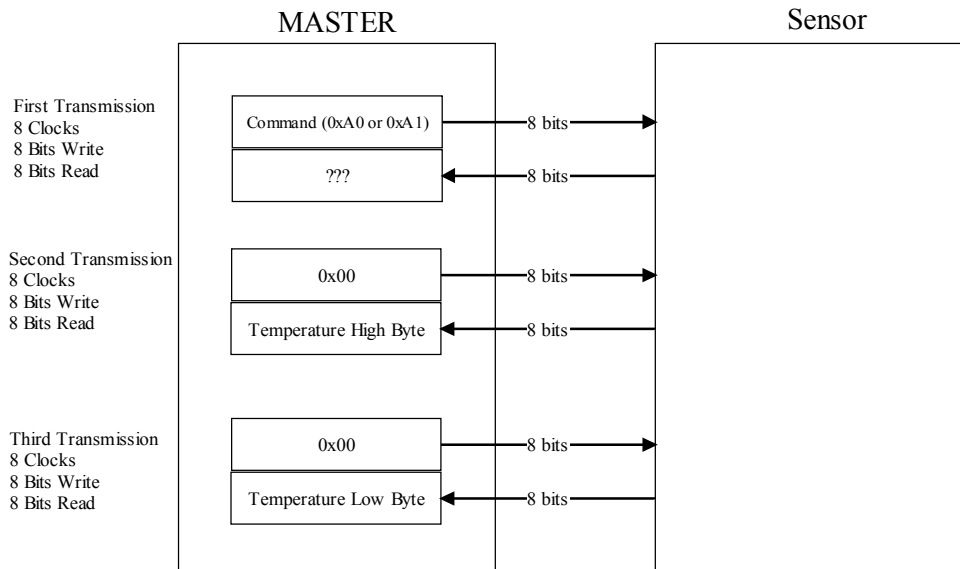

## EXAMPLE OF TEMPERATURE CALCULATION

For reading object temperature send: 0xA1

Return values i.e.:

Byte(0) = ???      discard reading

Byte(1) = 0x1A      (=26)

Byte(2) = 0xB0      (=176)

$T_{obj} = (256 * \text{Byte}(1) + \text{Byte}(2)) / 100 = (256 * 26 + 176) / 100 = 68.32^{\circ}\text{C}$

## NAMING CONVENTION

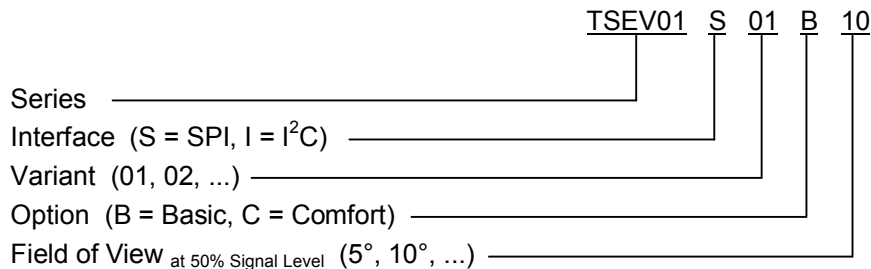

# TSEV01S01C05

## ORDER INFORMATION

---

Please order this product using following:

Part Number	Part Description
G-TPMO-025	TSEV01S01C05

## EMC

---

Due to the use of these modules for OEM application no CE declaration is done.

Especially line coupled disturbances like surge, burst, HF etc. cannot be removed by the module due to the small board area and low price feature. There is no protection circuit against reverse polarity or over voltage implemented.

The module will be designed using capacitors for blocking and ground plane areas in order to prevent wireless coupled disturbances as good as possible.

## 联系方式

---



深圳市亿为测控电子有限公司  
Shenzhen Bill-Well Measurement & Control Electronics Co., Ltd.

广东省深圳市南山区创业路怡海广场东座2407 邮编：518000

电话：+86 755 2641 9890 传真：+86 755 2641 9680

电子邮箱：sales@bill-well.com