

- Contact less Temperature Measurement
- Small Field of View
- High Accuracy
- Small Size
- Wide Supply Voltage Range
- Digital Interface Bus (I2C)

DESCRIPTION

TSEV01CL55 is a contact-less temperature measuring system for OEM use based on the detection of infrared radiation.

TSEV01CL55 is equipped with an infrared sensor (Thermopile) in front. The Thermopile Sensor has to be pointed at the target object of interest.

The basic working principle is:

- Detection of infrared radiation with a Thermopile sensor, which turns incoming radiation to an analogue voltage
- Determination of sensor temperature using a thermistor
- Calculation of ambient and object temperature using a processing unit
- Providing the ambient and objects temperature at digital output bus (I²C)

The TSEV01CL55 is suitable for a wide range of application where non-contact temperature measurement is required.

This document corresponds to TSEV01CL55 Version V1.4

FEATURES

0°C – 300°C Measurement Range
Small Field of View
4V – 16V Supply Voltage Range
Up to 1.5% Accuracy
2mA Current Consumption

APPLICATIONS

Contact less Temperature Measurement
Climate Control
Industrial Process Control
Household Applications

TSEV01CL55 Thermopile Sensor Module

ABSOLUTE MAXIMUM RATINGS

Absolute maximum ratings are limiting values of permitted operation and should never be exceeded under the worst possible conditions either initially or consequently. If exceeded by even the smallest amount, instantaneous catastrophic failure can occur. And even if the device continues to operate satisfactorily, its life may be considerably shortened.

Parameter	Symbol	Conditions	Min	Typ	Max	Unit
Supply Voltage	Vcc	Measured versus GND	-0.3		16	V
Operating Temperature	Top		-10		85	°C
Storage temperature	Tstor		-40		85	°C

OPERATING CONDITIONS

Parameter	Symbol	Conditions	Min	Typ	Max	Unit
Supply voltage	Vcc	Measured versus GND	4	5	16	V
Emission Coefficient	ϵ		0.95			

OPERATIONAL CHARACTERISTICS

If not otherwise noted, 25°C ambient temperature, 5V supply voltage and object with $\epsilon = 0.98$ were applied.

Parameter	Symbol	Conditions	Min	Typ	Max	Unit
Object Temperature Range	Tobj		0		300	°C
Ambient Temperature Range	Tamb		0		100	°C
Field of View	FOV			14 ¹⁾		°
Supply Current	I	Full ambient temp. range, no output load	1	2	4	mA
I2C Baudrate	F _{I2C}		10		50	kHz
Data Output Rate	F _{out}			1		Hz
Standard Start-Up Time	t _{Start}				5	s
Accuracy tolerance when 10°C < T _{ambient} < 40°C and after 3 minutes stabilization time	ΔT	170°C < T _{object} < 190°C		±1.5 ²⁾		%FS
		Outside above range		±2.5 ²⁾		%FS

¹⁾ Total field of view at 10% signal level

²⁾ The distance of sensor to measurement object has to be disclosed by customer in order to guaranty calibration accuracy.

TSEV01CL55 Thermopile Sensor Module

MECHANICAL DIMENSIONS

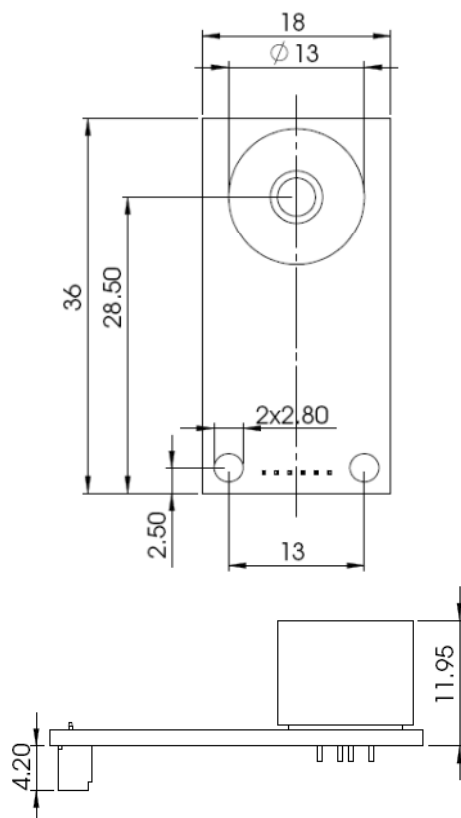

Units: mm

TERMINALS

Connector: Molex 51021-0600 (Farnell-In-One: 1012261, Digikey: WM1724-ND)

Pin	Name	Description	Type
1	NC		
2	NC		
3	SDA	I2C Data (3.6V)	Interface
4	SCL	I2C Clock (3.6V)	Interface
5	GND	Ground	Supply
6	VCC	Supply Voltage (5V)	Supply

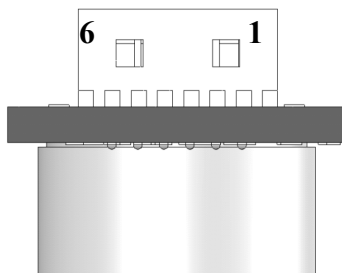

TSEV01CL55 Thermopile Sensor Module

BLOCK DIAGRAM

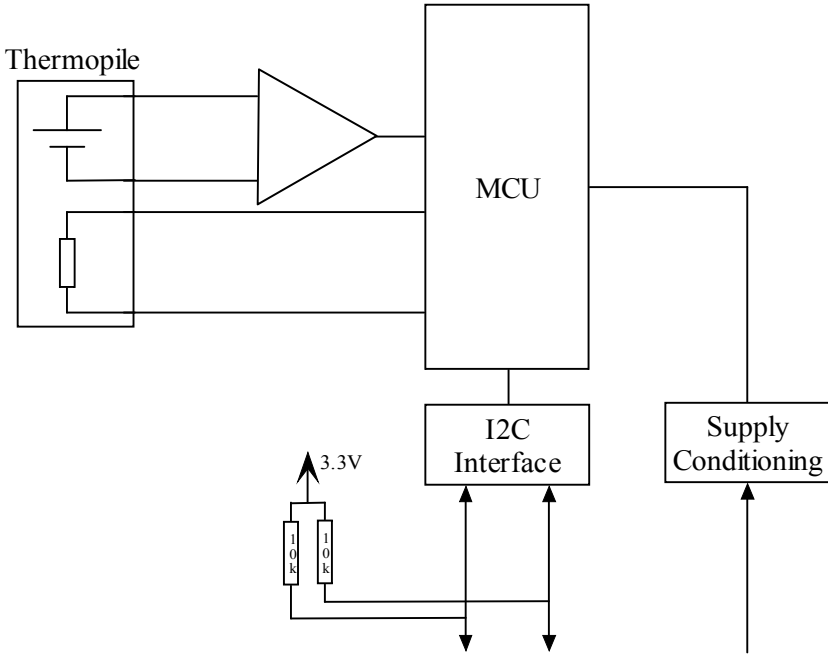

FIELD OF VIEW

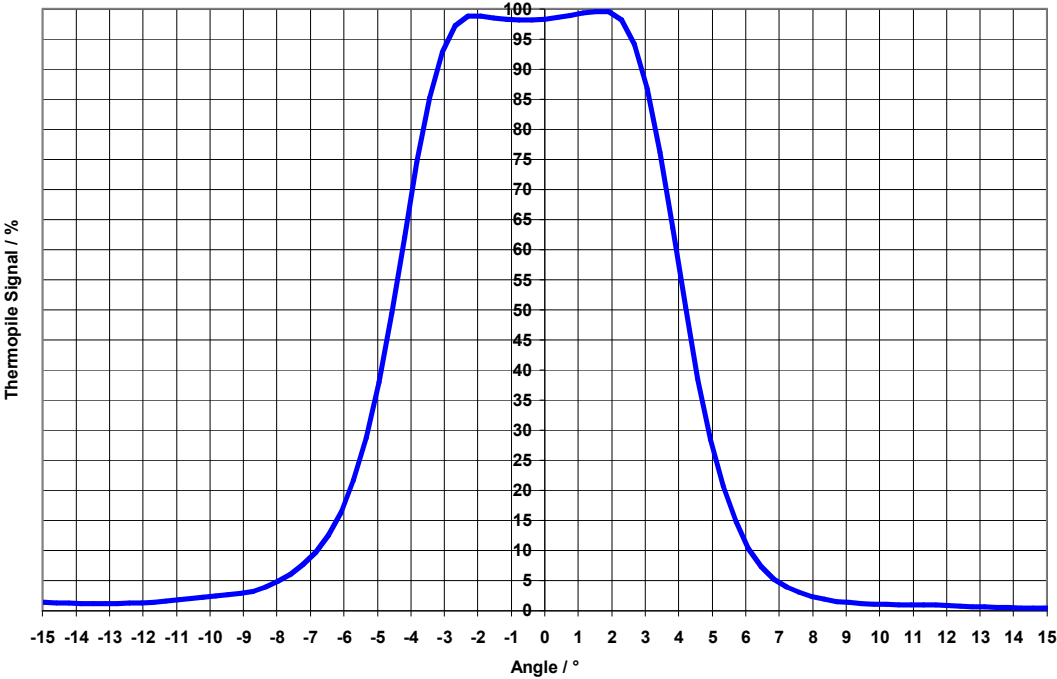

TSEV01CL55 Thermopile Sensor Module

SIGNAL DISTRIBUTION

The non-ideal filter characteristics have to be considered for the correct measurement distance with respect to the measurement object surface size. To achieve most accurate measurement results, measurement object should at least cover 99% of the sensors field of view.

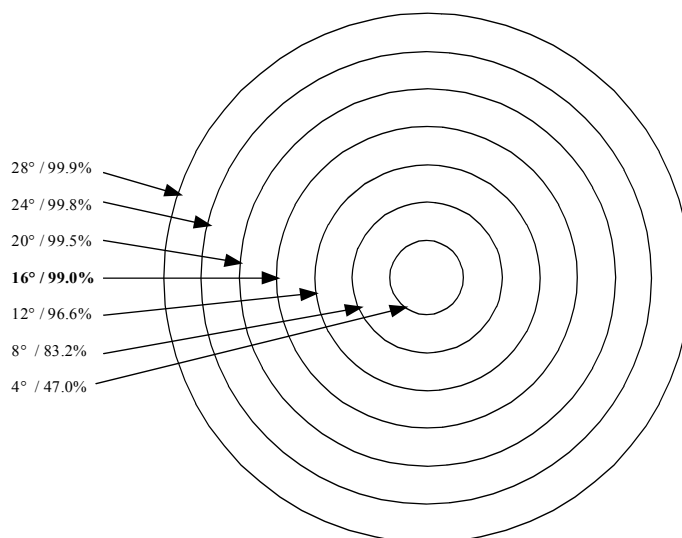

FUNCTION

I²C INTERFACE

This module is always operating in pure slave modus of a two wire interface similar to I²C. The typical baud rate of this device is 20kBit/s. The supported address length is seven bits. The I²C slave address is 54h.

Pull-up resistors of 10kOhm are provided on the board.

PHYSICAL INTERFACE PARAMETERS

Parameter	Min	Typical	Max	Unit
Baudrate	10	---	50	kBit/s
Address length	---	7	---	Bit
Address (standard)	---	54h	---	---
Input High Level	2	---	3.6	V
Input Low Level	---	---	1	V
Output High Level	2.5	---	---	V
Output Low Level	---	---	1	V

TSEV01CL55 Thermopile Sensor Module

I2C COMMAND REFERENCE

AMBIENT AND OBJECT MEASUREMENT

Please refer following table for I²C commands to read object temperature and ambient temperature. Both values are transmitted in hundredth of degrees.

Command	Description	Reply	Bytes
0xB6	Read object temperature	Object temperature in hundredth of degree	2
0xB5	Read ambient temperature	Ambient temperature in hundredth of degree	2

EXAMPLE OF TEMPERATURE CALCULATION

For reading object temperature send: 0xB6

Return values i.e.: Byte(0) = 0x0E, Byte(1) = 0xAA

Temperature $T_{obj} = (256 * \text{Byte}(0) + \text{Byte}(1)) / 100 = (256 * 14 + 170) / 100 = \underline{37.54^{\circ}\text{C}}$

OUT OF RANGE INDICATION

In case of ambient or object temperature over exceeding specified temperature ranges temperature outputs showing following data:

Command	Description	Reply	Bytes
0xB6	Object temperature > 300°C	0xFFF0	2
0xB6	Object temperature < 0°C	0xFFF1	2
0xB5	Ambient temperature > 100°C	0xFFFF	2
0xB5	Ambient temperature < 0°C	0xF000	2

READING TEMPERATURE

I.e. object temperature.

WRITE SEQUENCE

Data	Direction
Start, Address (Write 0x54), Command (0xB6), Stop	Master → Slave

READ SEQUENCE

Data	Direction
Start, Address (Read 0x55)	Master → Slave
Master adds wait period of 1ms for slave to arrange data	Master → Slave
Read data (high byte of temperature)	Master ← Slave
Master adds wait period of 1ms for slave to arrange data	Master → Slave
Read data (low byte of temperature)	Master ← Slave
Stop	Master → Slave

TSEV01CL55 Thermopile Sensor Module

ORDER INFORMATION

Please order this product using following:

Part Number	Part Description
G-TPMO-011	TSEV01CL55

EMC

Due to the use of these modules for OEM application no CE declaration is done.

Especially line coupled disturbances like surge, burst, HF etc. cannot be removed by the module due to the small board area and low price feature. There is no protection circuit against reverse polarity or over voltage implemented.

The module will be designed using capacitors for blocking and ground plane areas in order to prevent wireless coupled disturbances as good as possible.

联系方式



深圳市亿为测控电子有限公司
Shenzhen Bill-Well Measurement & Control Electronics Co., Ltd.

广东省深圳市南山区创业路怡海广场东座2407 邮编：518000

电话：+86 755 2641 9890 传真：+86 755 2641 9680

电子邮箱：sales@bill-well.com