

Model TS418-3N426 Thermopile Sensor



Thermopile IR-Sensor
Filter for NDIR CO₂ Gas Detection
Single Element
Very High Signal
Flat Filter
Small Package
Accurate Reference Sensor



DESCRIPTION

Thermopiles are mainly used for contactless temperature measurement in many applications. Their function is to transfer the heat radiation emitted from the objects into a voltage output.

FEATURES

- Very High Signal
- Accurate Reference Sensor
- 4.26 μ m Narrow Band Pass
- Small TO-18 package

APPLICATIONS

- NDIR CO₂ Gas Detection

ABSOLUTE MAXIMUM RATINGS

Parameter	Symbol	Min	Typical	Max	Unit	Description
Storage Temperature	T _s	-20	+20	+85	°C	permanent
Storage Temperature	T _s	-20	+20	+100	°C	non permanent

Model TS418-3N426 Thermopile Sensor

PERFORMANCE SPECS

Parameter	Symbol	Value	Unit	Condition
Operating Ambient Temperature	T_{Amb}	-20 to +85	°C	permanent
Operating Ambient Temperature	T_{Amb}	-20 to +100	°C	non permanent
Package		TO-18		
Absorber Area	A	1.4×1.4	mm ²	
Thermopile Resistance	R_{TP}	180 ± 60	k Ω	$T_{Amb} = +25^{\circ}\text{C}$
Temperature Coefficient of Thermopile Resistance	TCR_{TP}	-0.06 ± 0.04	%/K	$T_{Amb} = +25^{\circ}\text{C}$ to $+75^{\circ}\text{C}$
Voltage Response	V_{TP}	depends on light source	mV	
Temperature Coefficient of Voltage Response	TCV_{TP}	-0.45 ± 0.08	%/K	$T_{Amb} = +25^{\circ}\text{C}$ to $+75^{\circ}\text{C}$
Noise Equivalent Voltage	NEV	130	nV/Hz ^{1/2}	$T_{Amb} = +25^{\circ}\text{C}$
Rise Time	τ_{63}	22 ± 5	ms	
Ambient Temperature Sensor		Ni-RTD		
Ambient Temperature Sensor Resistance	R_{Ni-RTD}	1000 ± 4	Ω	$T_{Amb} = 0^{\circ}\text{C}$
Temperature Coefficient of Ni-RTD	TC_{Ni-RTD}	6178 ± 150	ppm/K	$T_{Amb} = 0^{\circ}\text{C}$ to $+100^{\circ}\text{C}$

Model TS418-3N426 Thermopile Sensor

OPTICAL CHARACTERISTICS

Parameter	Symbol	Value	Unit	Description
Field of View	FOV	120	deg	at 50% of maximum signal

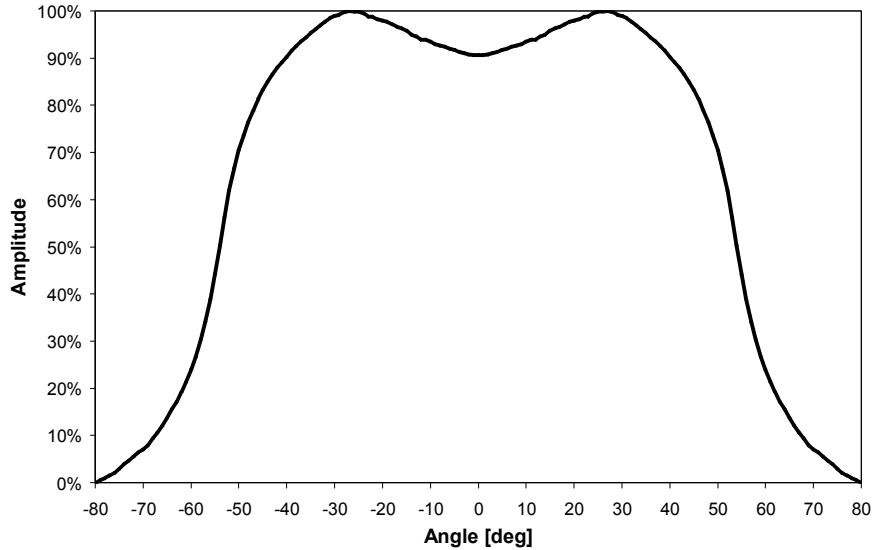

Figure 2: Field of View Curve

FILTER CHARACTERISTICS

Parameter	Symbol	Value	Unit	Description
Filter Type	NBP	4.26 ±0.18	μm	Narrow Band Pass

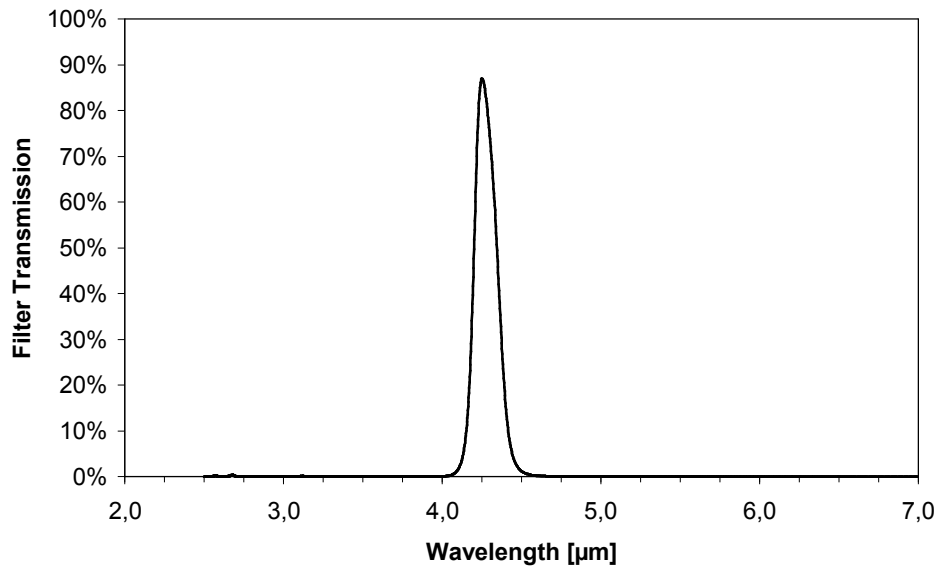

Figure 3: Filter transmission curve

Model TS418-3N426 Thermopile Sensor

ELECTRICAL CONNECTIONS

Pin	Symbol
1	TP +
2	Ni-RTD
3	TP -
4	GND

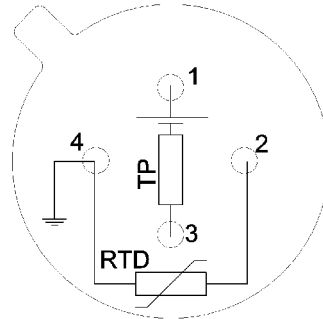

Figure 4: Electrical connections - bottom view of thermopile

MECHANICAL DIMENSIONS

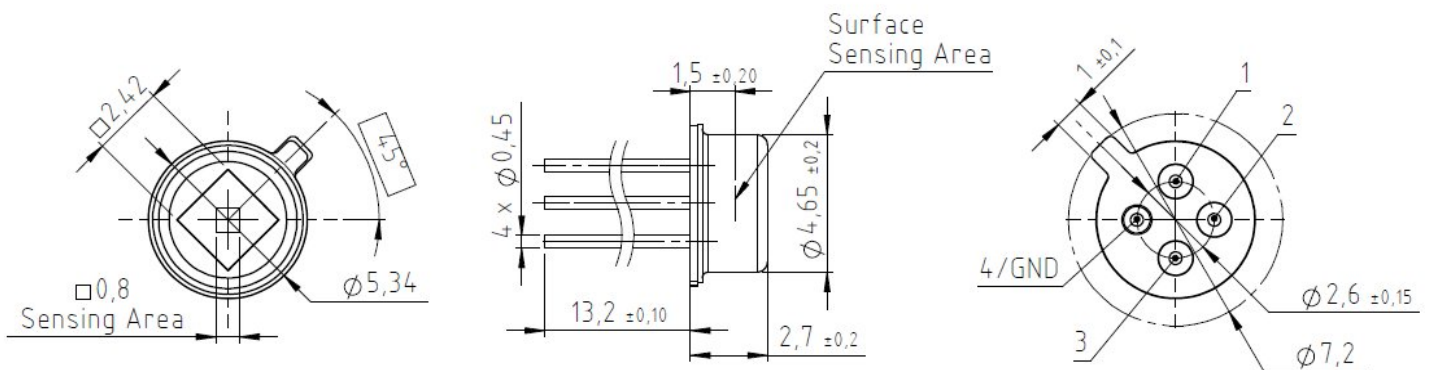

Figure 5: Mechanical dimensions of thermopile

Model TS418-3N426 Thermopile Sensor

ORDERING INFORMATION

Part Description TS418-3N426

Part No. G-TPCO-024

联系方式



深圳市亿为测控电子有限公司
Shenzhen Bill-Well Measurement & Control Electronics Co., Ltd.

广东省深圳市南山区创业路怡海广场东座2407 邮编：518000

电话：+86 755 2641 9890 传真：+86 755 2641 9680

电子邮箱：sales@bill-well.com