

# TRICAN HTD2800P1B11C6 – Digital RH/T/P module



- Combo sensor (Specific Humidity, Temperature and Pressure)
- Optimized design for high RH, high T°C environment
- Digital output as per J1939, CAN2.0B standard or CAN 2.0A
- Rugged, automotive graded sensor
- High resistance to chemicals
- Customizable CAN Frame
- Optional output for NOx humidity correction factor

## DESCRIPTION

Based on a rugged and qualified combo sensor, TRICAN HTD2800P1B11C6, digital humidity sensor with temperature and pressure outputs, is a cost effective dedicated humidity, temperature and pressure transducer designed for automotive and truck applications where a reliable and accurate measurement is needed. The information is delivered as a digital output on a CAN bus. The TRICAN HTD2800P1B11C6 design has been optimized to provide accurate information and fast response time for systems where repeated long term immersion in high humidity and high temperature environment is needed as air intake ducts, fuel cell systems.

## FEATURES

- Demonstrated reliability and long term stability
- Reliability not affected by repeated condensation
- Fast response time even in saturated humidity environment

## APPLICATIONS

- Trucks (diesel market) + off road
- Industrial (compressor and genset (diesel))
- Fuel Cell Systems
- ...

## PERFORMANCE SPECS

### MAXIMUM RATINGS

Ratings	Symbol	Value	Unit
Storage Temperature	T <sub>stg</sub>	-40 to +125	°C
Supply Voltage (Peak)	V <sub>cc</sub>	32	V <sub>dc</sub>
Humidity Operating Range	RH	0 to 100	%RH
Temperature Operating Range*	T <sub>a</sub>	-40 to +105	°C
Max Pressure (Burst)	P <sub>abs</sub>	130	kPa

\* At the tip of the sensor

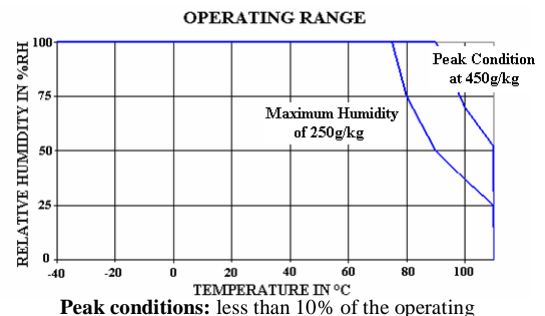

# TRICAN HTD2800P1B11C6 – Digital RH/T/P module

## BLOCK DIAGRAM

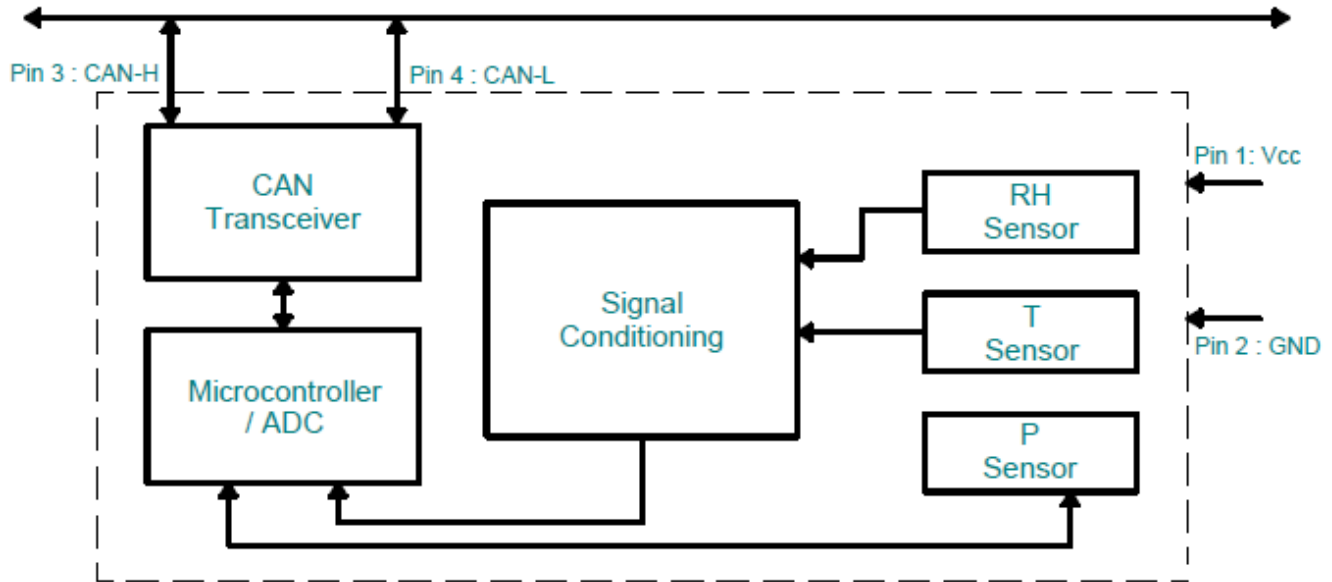

## CHARACTERISTICS

(@T=23°C)

Electrical Characteristics	Symbol	Min	Typ	Max	Unit
Voltage supply (Vbatt)	V	8	12 or 24	32	VDC
Current consumption	mA		15 (At 12V) 20 (At 24V)	100 (At 12V) 104 (At 24V)	mA
Sink current capability	mA		150		mA

CAN Bus Timing	Symbol	Min	Typ	Max	Unit
Bit time	μs	3.999	4	4.001	μs
CAN_H CAN_L slew rate	V/μs		7		V/μs

CAN_H & CAN_L limiting values	Symbol	Min	Typ	Max	Unit
DC voltage at CAN_L		-36		+36	V
DC voltage at CAN_H		-36		+36	V
Transient voltage on CAN_H & CAN_L		-200		+200	V

DC Bus Receiver*	Symbol	Min	Typ	Max	Unit
Differential input voltage (recessive)		-1.0		+0.5	V
Differential input voltage (dominant)		0.9		5.0	V
Differential input hysteresis		-	150	-	mV
CAN_H, CAN_L input resistance		5		25	Kohm
Differential input resistance		20		100	Kohm

\* (Transceiver Vcc 4,5 to 5,5V ; RL = 60 ohm)

# TRICAN HTD2800P1B11C6 – Digital RH/T/P module

Humidity Characteristics	Symbol	Min	Typ	Max	Unit
Humidity Measuring Range	RH	0		100	%RH
Relative Humidity Accuracy (10% to 95%RH)			±3	±5	%RH
Relative humidity Resolution			0.4		%RH
Time Constant (at 63% of signal) 33%RH to 75%RH <sup>(1)</sup>	$\tau$		5	10	s
Humidity hysteresis			+/-1		%RH
Time Constant (at 63% of signal) 33%RH to 75%RH <sup>(1)</sup>	$\tau$		5	10	s
Long term stability			+/-0.5		%RH /Yr

Pressure	Symbol	Min	Typ	Max	Unit
Absolute pressure measuring range	kPa	1	-	250	kPa
Pressure measuring range with full accuracy guaranteed	kPa	30		130	kPa
Pressure accuracy			+/-1	+/-1.5	%FS
Pressure resolution			+/-0.5		kPa
Time Constant	$\tau$		1		s
Long term stability			+/-0.5		kPa /Yr

Temperature Characteristics	Symbol	Min	Typ	Max	Unit
Temperature measuring range	$T_a$	-40		105	°C
Temperature accuracy			+/-0.5	+/-1.5	°C
Time Constant <sup>(1)</sup>	$\tau$		10		S
Long term stability			+/-0.3		°C/Yr

(1) At 2m/s air flow

# TRICAN HTD2800P1B11C6 – Digital RH/T/P module

## CAN BUS INTERFACE

The system is J1939 Standard compliant. The system delivers temperature (SPN 1172), inlet pressure (SPN 1176) , relative humidity (SPN 354) and Specific Humidity (SPN4490) . Identifier, transmission repetition rate, data length, ranges, and resolutions are defined by J1939 or specified by customer. Optional and customizable output for Dew point through internal calculation in accordance with EPA methodology is also available.

### CAN 2.0B/J1939 FRAME DESCRIPTION

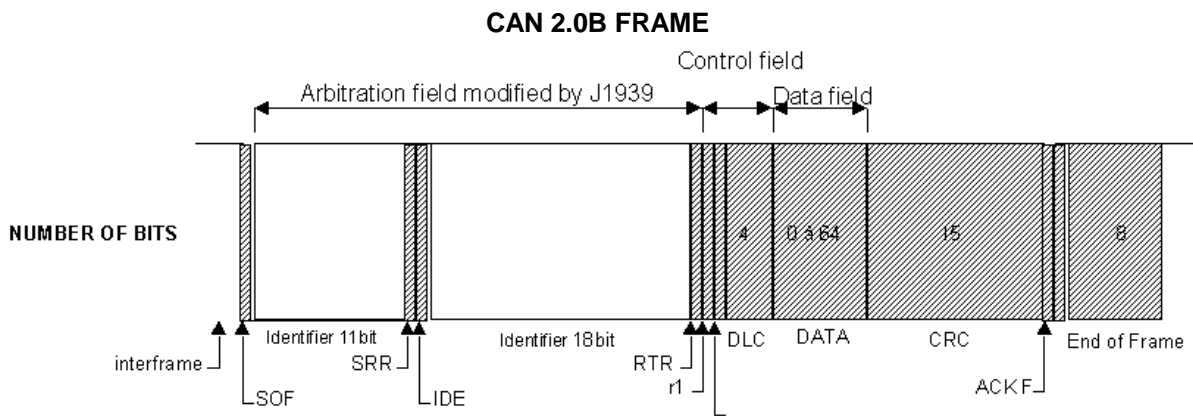

### ARBITRATION / IDENTIFICATION FIELD

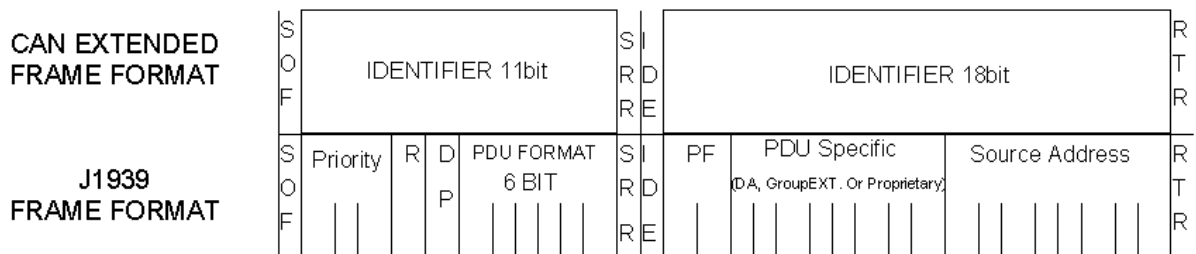

# TRICAN HTD2800P1B11C6 – Digital RH/T/P module

## TRICAN HTD2800P1B11C6 STANDARD SPN

Inlet pressure	SPN 1176	Data length	2 byte
		Resolution	0,1KPa/bit gain, -250 KPa offset
		Data range	-250kPa to 251,99 kPa
Relative humidity	SPN 354	Data length	1byte
		Resolution	0.4%RH/bit gain, 0%RH offset
		Data range	0 to 100%RH
Specific humidity	SPN 4490	Data length	2 byte
		Resolution	0.01 g/kg, 0 g/kg offset
		Data range	0 to 642.55 g/kg
Air inlet temperature	SPN 1172	Data length	2 byte
		Resolution	0,03125°C/bit gain, -273°C offset
		Data range	-273 to1735°C

## SELF DIAGNOSTIC CAPBILITES

Optional and customizable diagnostic byte can be implemented

- Pressure failure sensor (no communication or internal CRC issues)
- Pressure failure sensor (out of range issue)
- Temperature sensor circuit - voltage above normal
- Temperature sensor circuit - voltage below normal
- Humidity sensor circuit - voltage above normal
- Humidity sensor circuit - voltage below normal
- Sensor controller over temperature conditions (105°C)
- SH internal computation / calculation out of range or wrong CRC value

## SAE J1939-21 REQUEST

Optional and customizable answers to SAE J1939-21 request can be implemented

- Address claim (PGN 60928)
- Software identification (PGN 65242)
- Calibration information DM19 (PGN 54016)
- Status code message (PGN TBD)

# TRICAN HTD2800P1B11C6 – Digital RH/T/P module

## CONNECTING AND MECHANICAL CHARACTERISTICS

### NOMENCLATURE

#### HTD2800P1B11C6

Connector Type: Customizable upon request

### CONNECTING CHARACTERISTICS

Bosch mating connector: 1 928 403 736  
 Recommended contacts: 1 928 498 054

Signal	Pin
VCC	1
GND	2
CANH	3
CANL	4

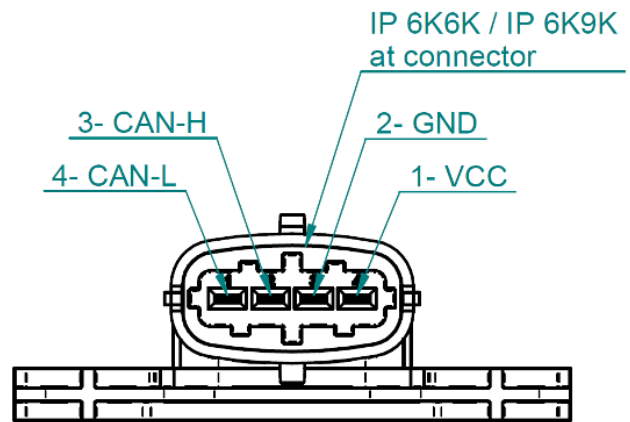

### MECHANICAL CHARACTERISTICS:

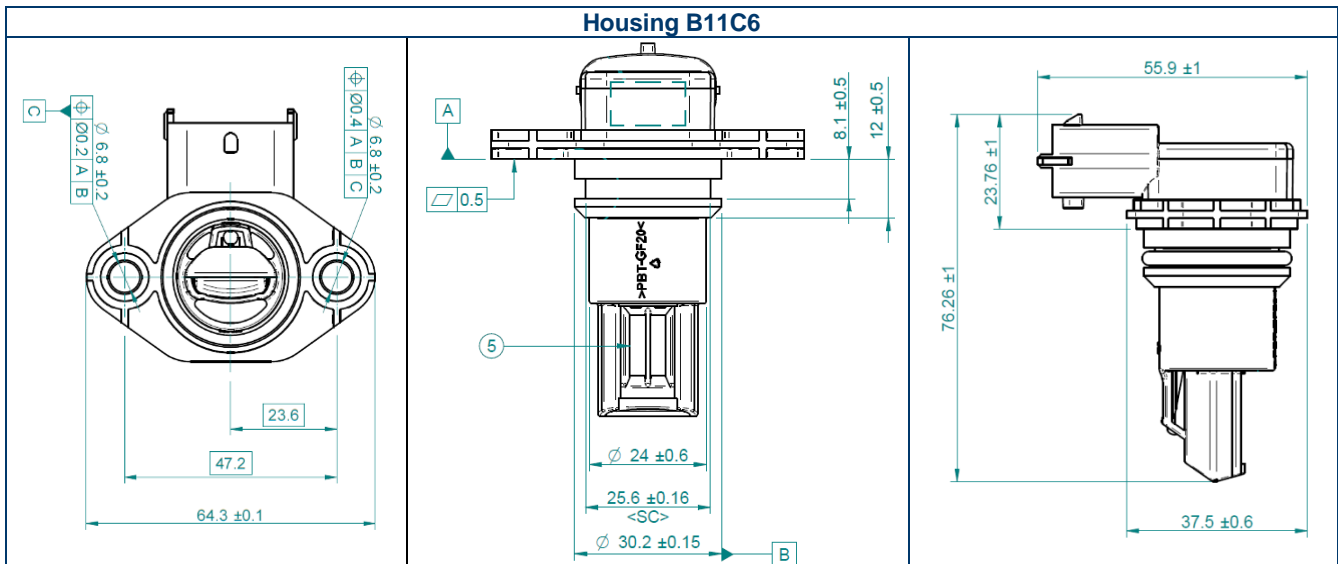

Recommended Screw Mounting: M6 ; Typical tightening torque: 12 N.m ; Maximum tightening torque: 17 N.m

# TRICAN HTD2800P1B11C6 – Digital RH/T/P module

## RESISTANCE TO PHYSICAL AND CHEMICAL STRESSES

- TRICAN HTD2800P1B11C6 meets qualification requirements of MEAS FRANCE including vibration, mechanical and thermal shock, storage, high and low temperature, humidity and pressure, ESD and EMC
- Additional tests under harsh chemical conditions demonstrate good operation in presence of salt atmosphere, SO<sub>2</sub> (0.5%), H<sub>2</sub>S (0.5%), O<sub>3</sub>, NO<sub>x</sub>, NO, CO, CO<sub>2</sub>, Softener, Soap, Toluene, acids (H<sub>2</sub>SO<sub>4</sub>, HNO<sub>3</sub>, HCl), HMDS, Insecticide, Cigarette smoke
- TRICAN HTD2800P1B11C6 is not light sensitive

## ORDERING INFORMATION

**HPP816E031 : HTD2800P1B11C6**

Revision	Comments	Who	Date
0	Document Creation	P.METRAL	February 14
1	Mechanical Characteristics view updated	P.METRAL	February 14

## 联系方式



深圳市亿为测控电子有限公司  
Shenzhen Bill-Well Measurement & Control Electronics Co., Ltd.

广东省深圳市南山区创业路怡海广场东座2407 邮编：518000

电话：+86 755 2641 9890 传真：+86 755 2641 9680

电子邮箱：sales@bill-well.com