

- Piezoelectric film sensor
- AC Coupled
- Silver Ink Electrodes
- Protective Coating over Electrodes
- Lead Wires Attached with Rivets

The **DT Series** of Piezo film sensors elements are rectangular elements of Piezo film with silver ink screen printed electrodes. They are available in a variety of different sizes and thicknesses. Lead attachment is accomplished using a riveted lug going to 12" (300 mm) of 28 AWG wire.

The DT film element produces more than 10 millivolts per micro-strain. The capacitance is proportional to the area and inversely proportional to the thickness of the element.

The DT elements are supplied with a thin protective coating over the active electrode area to prevent oxidation to the top surface of the silver ink.

FEATURES

- Minimum Impedance: 1 MΩ
- Preferred Impedance: 10 MΩ and higher
- Output Voltage: 10 mV to 100V depending on Force and Circuit Impedance
- Storage Temperature: -40°C to +70°C [-40°F to 160°F]
- Operating Temperature: 0°C to +70°C[32°F to 160°F]

APPLICATIONS

- Sensing Direct Contact Force
- Recording Time of an Event
- Counting Number of Impact Events
- Measuring Impact Related Events



typical piezo properties

Symbol	Parameter	PVDF	Units
t	Thickness	9, 28, 52, 110	μm
d ₃₁	Piezo Strain Constant	23	(10 ⁻¹²)C/N
d ₃₃		-33	
g ₃₁	Piezo Stress constant	216	(10 ⁻³)Vm/N
g ₃₃		-330	
k ₃₁	Electromechanical Coupling Factor	12%	
k _t		14%	
C	Capacitance	380 for 28μm	pF/cm ² . @ 1KHz
Y	Young's Modulus	2-4	10 ⁹ N/m ²
V ₀	Speed of Sound	2.2	10 ³ m/s in thickness direction

DT Series Elements with Lead Attachment

DIMENSION in INCHES (mm)

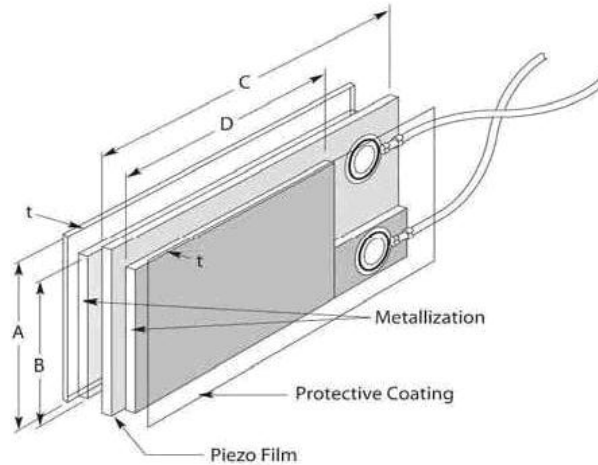

Model Number	Part Number	Film Thickness	A Film	B Electrode	C Film	D Electrode	Total Thickness (μm)	Cap (nF)
DT1-028K/L w/rivets	1-1002908-0	28 μm	.64 (16)	.484 (12)	1.63 (41)	1.19 (30)	40	1.38
DT1-052K/L w/rivets	2-1002908-0	52 μm	.64 (16)	.484 (12)	1.63 (41)	1.19 (30)	64	.740
DT2-028K/L w/rivets	1-1003744-0	28 μm	.64 (16)	.484 (12)	2.86 (73)	2.42 (62)	40	2.78
DT2-052K/L w/rivets	2-1003744-0	52 μm	.64 (16)	.484 (12)	2.86 (73)	2.42 (62)	64	1.44
DT4-028K/L w/rivets	1-1002150-0	28 μm	.86 (22)	.740 (19)	6.72 (171)	6.72 (171)	40	11.00
DT4-052K/L w/rivets	2-1002150-0	52 μm	.86 (22)	.740 (19)	6.72 (171)	6.72 (171)	64	5.70

联系方式



深圳市亿为测控电子有限公司
Shenzhen Bill-Well Measurement & Control Electronics Co., Ltd.

广东省深圳市南山区创业路怡海广场东座2407 邮编：518000

电话：+86 755 2641 9890 传真：+86 755 2641 9680

电子邮箱：sales@bill-well.com