



- **Piezoelectric film sensor without lead attachments**
- **Silver ink electrode**
- **Available in different sizes and thicknesses**
- **Great for making your own sensor**

DESCRIPTION

The DT series of piezo film sensors elements are rectangular elements of piezo film with silver ink screen printed electrodes. They are available in a variety of different sizes and thicknesses.

The DT film element produces more than 10 millivolts per microstrain, about 60 dB higher than the voltage output of a foil strain gauge. The capacitance is proportional to the area and inversely proportional to the thickness of the element.

The DT series sensors are the simplest form of piezo film sensors, used primarily as dynamic strain gages and contact microphones for vibration or impact detection. These are available without any leads for those applications where the customer wants to make his own lead attachment. They can be readily adhered to a surface with double-sided tape or epoxy. Lead attachment can be achieved by compressive clamping, crimps, eyelets, conductive epoxy or low temperature solders.

FEATURES

- Thin Piezo polymer w/ high piezo activity
- Flexible silver ink metallization
- Min. impedance- 1M Ω , recommended 10M Ω
- Output voltage- mV to 100's of volts
- Operating temp: -40 to 60°C

APPLICATIONS

- Sensing contact forces
- Recording the time of an event
- Counting the number of impacts
- Make your own sensor element

DT Sensors

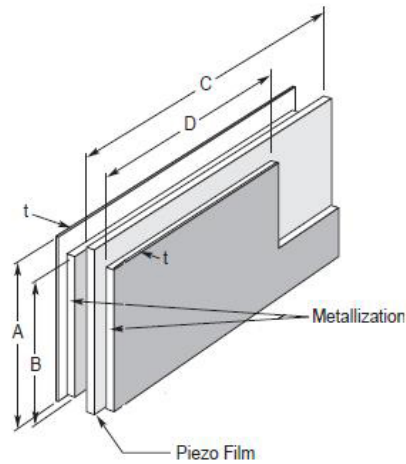

Description	Dimensions in inches [mm]					T(μ m)	Cap(nF)	Part Number
	A Film	B Electrode	C Film	D Electrode				
DT1-028K	0.64 (16)	0.484 (12)	1.63 (41)	1.19 (30)	40	1.38	1-1002608-0	
DT1-052K	0.64 (16)	0.484 (12)	1.63 (41)	1.19 (30)	64	0.74	2-1002608-0	
DT2-028K	0.64 (16)	0.484 (12)	2.86 (72)	2.42 (62)	40	2.78	1-1002145-0	
DT2-052K	0.64 (16)	0.484 (12)	2.86 (72)	2.42 (62)	64	1.44	2-1002145-0	
DT4-028K	0.86 (22)	0.740 (19)	6.72 (171)	6.13 (156)	40	11	1-1002149-0	
DT4-052K	0.86 (22)	0.740 (19)	6.72 (171)	6.13 (156)	64	5.7	2-1002149-0	

ORDERING INFO



联系方式



深圳市亿为测控电子有限公司
Shenzhen Bill-Well Measurement & Control Electronics Co., Ltd.

广东省深圳市南山区创业路怡海广场东座2407 邮编：518000

电话：+86 755 2641 9890 传真：+86 755 2641 9680

电子邮箱：sales@bill-well.com