

80 kHz Cylindrical Ultrasound Transducer

Omni-directional Horizontal Beam Directivity
Broad Bandwidth
Low Resonance Q
Excellent Impact Resistance
Lightweight
Low Cost

Piezoelectric Film (PVDF) 80 kHz Ultrasound Transducers offer unique advantages for air ranging applications. Cylindrical 80kHz PVDF transducers exhibit omni-directional horizontal beam directivity and broad bandwidth characteristics. These characteristics lend unique solutions in many applications such as two-dimensional positioning, digitizer, object detection, and distance measurement. Depending on the applications, resonance frequency and vertical beam directivity of the transmitter can easily be customized by changing the diameter and length of the PVDF cylinder.

PVDF ultrasound transducers also have very low resonance "Q" values. Typically, PVDF transmitters have a Q value of 5. This means that the signal rise and decay times are much shorter than conventional ceramic ultrasound transducers. This characteristic is ideal for positioning applications.



FEATURES

- PVDF Thickness: 30 μm
- Resonance Frequency: 80-90 kHz
- Resonance Q: 4-8 Transmitter; 6-9 Receiver
- Sound Pressure Output: 6 mPa/Vp 102 dB
- Sensitivity: 0.3 mV/Pa, -90 dB
- Horizontal Beam Directivity: 360°
- Vertical Beam Directivity: $\pm 25^\circ$
- Capacitance: 200 pF
- Drive Voltage: max 400 Vp, max. 100 Vp
- Storage Temperature: -20°C to +85°C
- Operating Temperature: +5°C to +60°C

APPLICATIONS

- Air Ranging Distance Measurement
- Object Detection
- Position Detection
- Digitizers
- Ultrasonic Mouse

80 kHz Cylindrical Ultrasound Transducer

specifications

Characteristics	Transmitter Mode	Receiver Mode	Units
PVDF Thickness	30	30	μm
Resonance Frequency	80 – 90	80 – 90	kHz
Resonance Q	4 – 8	6 - 9	
Sound Pressure Output	6		mPa/V
	102		dB
Sensitivity		0.3	mPa/V
		-90	dB
Horizontal Beam Directivity	360	360	Degree
Vertical Beam Directivity	±25	±25	Degree
Capacitance	200	200	pF
Drive Voltage	max 400		Vp
	max 100		
Storage Temperature	-20 to +85	-20 to +85	°C
Operating Temperature	+5 to +60	+5 to +60	°C

mechanical dimensions

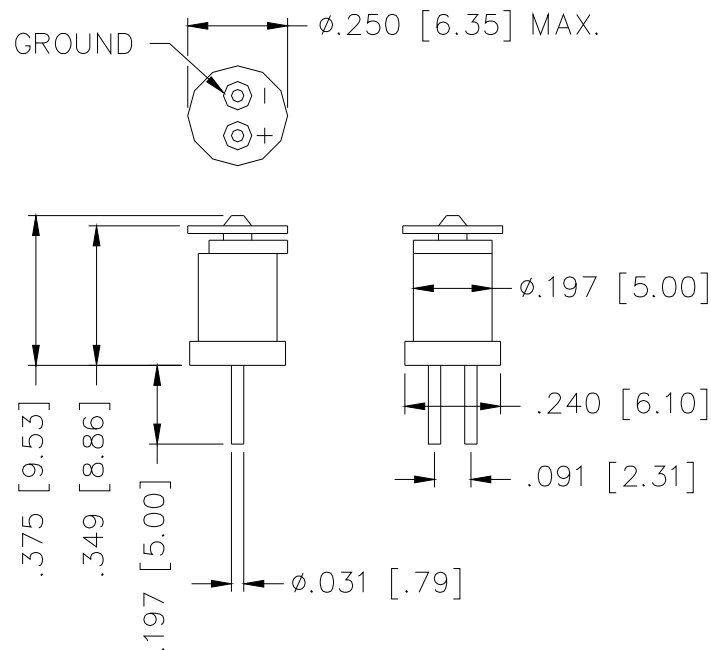

80 kHz Cylindrical Ultrasound Transducer

typical interface circuits

(a) Transmitter Drive Circuit Example

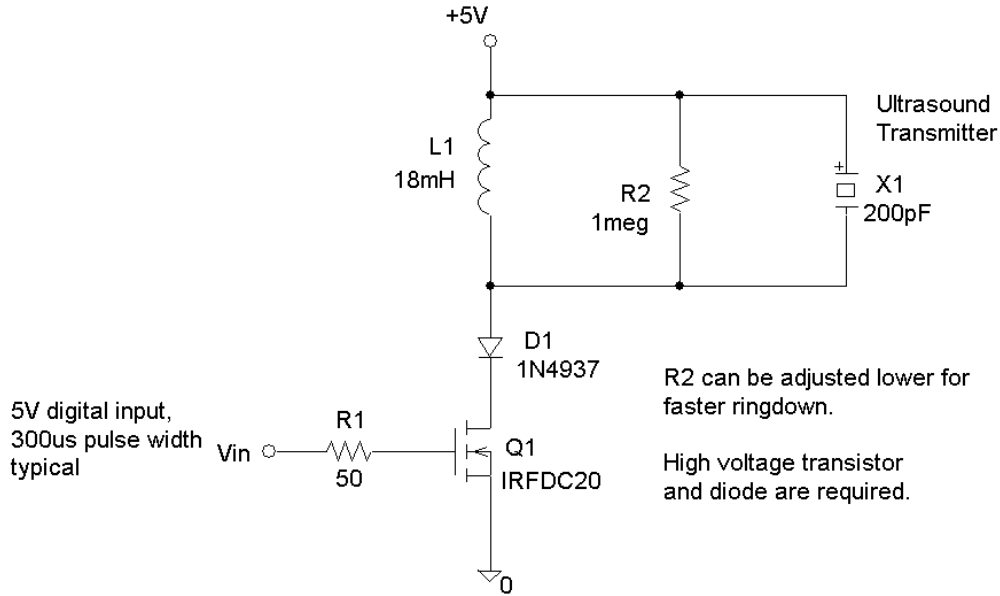

(b) Receiver Amplifier Circuit Example

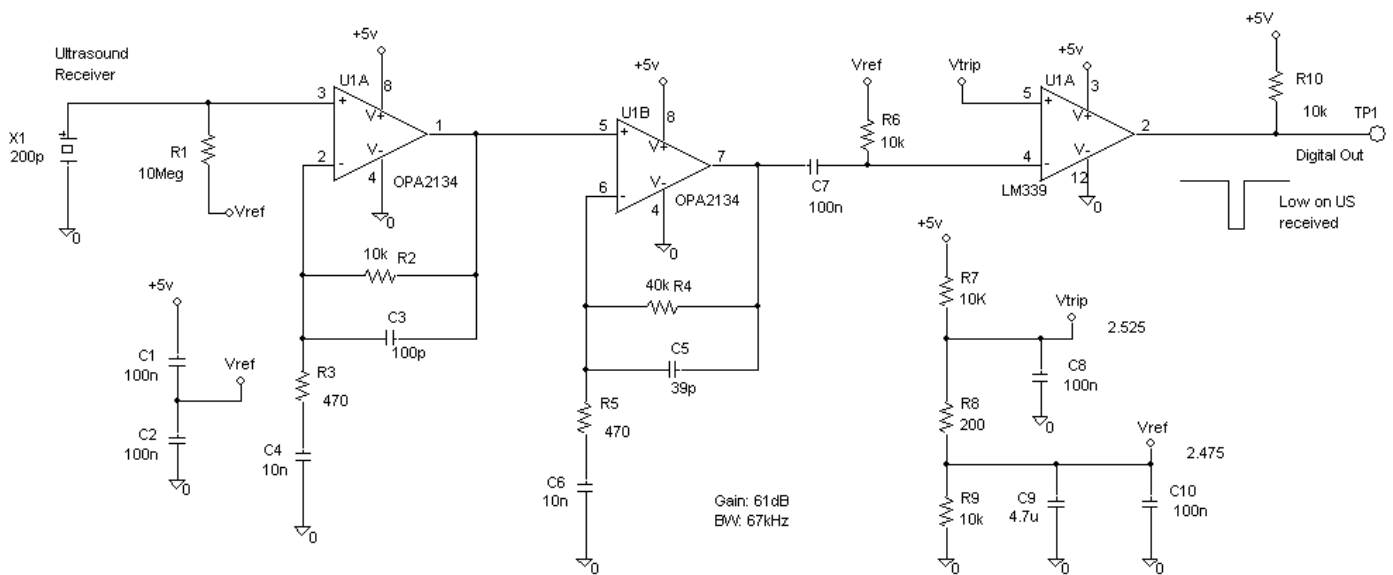

80 kHz Cylindrical Ultrasound Transducer

Typical Time Response of PVDF Transmitter and Receiver System

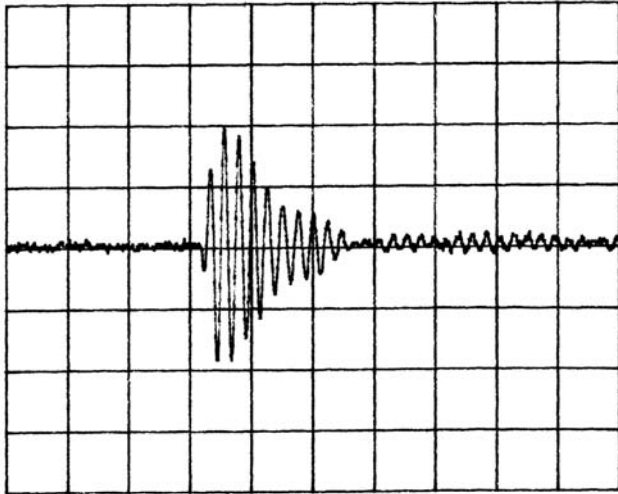

The plot at left shows the time-domain response obtained when one device is driven as a transmitter, and another is used as receiver at a distance of 30 cm. The drive signal comprised a single cycle at 400 V pk-pk. Receiver gain was +26 dB.

(Scale: time (X) 50 us/div, amplitude (Y) 2mV/div)

Frequency Response: 80 kHz pair (typ)

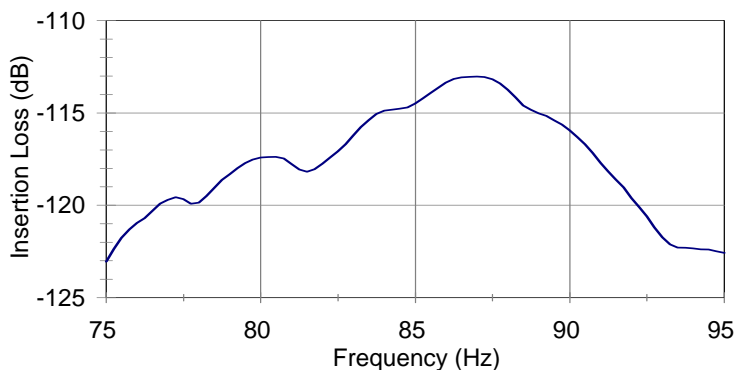

The plot at left shows an estimate of the frequency response curve for two identical units, one driven as transmitter, the other acting as a receiver. The spectrum of the received signal was divided by that of the drive signal and gain stage, giving the overall insertion loss as a function of frequency (measured at 30 cm distance, in air).

Note that the Q factor (center frequency divided by -6 dB bandwidth) for the complete system is very low: around 5.4 in the plot shown above. The minimum value of insertion loss was -113 dB at 87 kHz. This means that a 1Vrms drive signal at this frequency would create a 2.2 μ Vrms response. Thus, higher voltage drive signals are preferred (see section entitled "Design Notes" below), and relatively high gain may be required in the receiver electronics.

40 kHz Omni-Directional Ultrasound Transmitter

design notes

- Transmitter sound pressure output is linearly proportional to the drive voltage.
- Maximum drive voltage for PVDF transmitter is 400 V_{peak} for a single pulse and 100 V_{peak} for continuous pulses.
- Operating frequency may be selected in the range 80KHz to 90KHz (low Q transducer).
- Shielding is necessary for the ultrasound receiver and preamplifier circuit to minimize electromagnetic pick-up. Make sure the outer electrode of PVDF receiver is grounded.
- Input capacitance of preamplifier should be less than PVDF receiver capacitance (200pF typical) to minimize loading effects.
- To maximize S/N ratio, a narrow band-pass filter is recommended. On the other hand, if the filter has too narrow a pass-band, signal strength may be decreased. An example of pass band is 70KHz - 100K.
- Selection of input resistance is important to maximize the S/N (10M ohm is used in the above preamplifier circuit example).
- Low noise amplifiers are recommended.

ordering information

Description	Part #
80KHz Transducer w/o cage	1005919-1

联系方式



深圳市亿为测控电子有限公司
Shenzhen Bill-Well Measurement & Control Electronics Co., Ltd.

广东省深圳市南山区创业路怡海广场东座2407 邮编：518000

电话：+86 755 2641 9890 传真：+86 755 2641 9680

电子邮箱：sales@bill-well.com