

Pen Tip Assembly

Omni-directional Horizontal Beam Directivity
 Broad Bandwidth
 Low Resonance Q
 Excellent Impact Resistance
 Lightweight
 Low Cost



Pen Tip Assembly is well matched to Shielded Receiver Assembly.

Piezoelectric Film (PVDF): The cylindrical transducer gives a full 360° horizontal directivity and broad bandwidth in a very compact format.

FEATURES

- Ultrasonic Transducer
- Wide Angle GaAs IrLEDs
- Flexible Printed Circuit
- Strip & Plastic Tip Guard Assembly

APPLICATION

- Digitizer Pen

mechanical dimensions

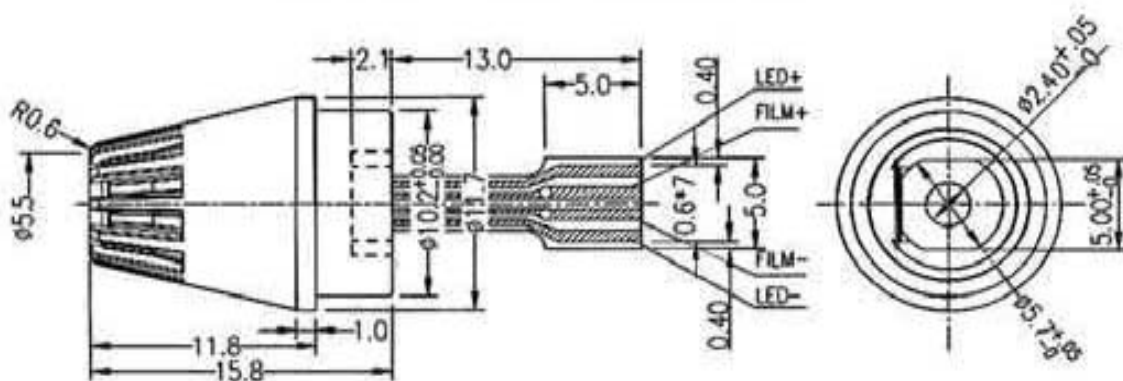

Pen Tip Assembly

Transmitter Specifications

Parameter	Typical Value, at TA = 25°C	Units	Notes
Operating Frequency	80 – 90	kHz	
Resonance Q	6 – 9	(none)	-3dB frequencies
Sound Pressure Output	8	mPa/V	@ 30 cm, 16-cycle sine burst re 20 µPa, @ 30 cm, @
Sound Pressure Level	101	dB	400 Vp-p 16-cycle sine burst @ 800 Vp-p decaying
Signal Output	4	mV	@ 800 Vp-p decaying sine drive, using
Horizontal Beam Directivity	360	+26dB, 2 nd positive peak	SR80KHZ-01, @ 30 cm, gain
Vertical Beam Directivity	>90	Degrees	
Capacitance (at resonance)	166	Degrees	to -6dB level
		pF	

Absolute Maximum Ratings at TA = 25°C:

Drive Voltage (burst mode)	800	Vp-p
Drive Voltage (continuous)	200	Vp-p
Storage Temperature	-20 to +80	°C
Operating Temperature	+5 to +60	°C

ordering information

Description	Model #	Part #
Pen Tip Assembly	PT80kHz-01	1007089-1
Shielded receiver Assembly	SR80kHz-01	1007090-1

联系方式



深圳市亿为测控电子有限公司
Shenzhen Bill-Well Measurement & Control Electronics Co., Ltd.

广东省深圳市南山区创业路怡海广场东座2407 邮编：518000

电话：+86 755 2641 9890 传真：+86 755 2641 9680

电子邮箱：sales@bill-well.com