

## FS20 Low Force Compression Load Cell



- 750 and 1500 Grams-Force
- High Level Output
- Interchangeable
- Industry Standard Packaging
- CE Compliance



### DESCRIPTION

The FS20 is a low compression force sensor that creates new markets previously unrealizable due to cost and performance constraints. The FS20 offers normalized zero and span for interchangeability and is thermally compensated for changes in zero and span with respect to temperature.

The FS20 incorporates MEAS' proprietary Microfused™ technology which employs micromachined silicon piezoresistive strain gages fused with high temperature glass to a high performance stainless steel substrate. Microfused™ technology eliminates age-sensitive organic epoxies used in traditional load cell designs providing excellent long term span and zero stability. The FS20 measures direct force and is therefore not subject to lead-die fatigue failure common with competitive designs which use a pressure capsule embedded within a silicone gel-filled cavity. Operating at very low strains, Microfused™ technology provides an essentially unlimited cycle life expectancy, superior resolution, and high over-range capabilities.

The FS20 brings your OEM product to life whether you need thousands or millions of load cells annually. Although the standard model is ideal for a wide range of applications, our dedicated design team at our Load Cell Engineering Center is ready to provide you with custom designs for your OEM applications.

Please refer to the FC22 and FC23 for higher force applications.

### FEATURES

- Small Size
- Low Noise
- Robust: High Over-Range Capability
- High Reliability
- Low Deflection
- Essentially Unlimited Cycle Life Expectancy
- Low Off Center Errors
- Fast Response Time
- Industry Standard Packaging
- 750 and 1500 Grams-Force Range
- Reverse Polarity Protected

### APPLICATIONS

- Robotics End-Effectors
- Variable Force Control
- Load and Compression Sensing
- Pumps
- Contact Sensing
- Weighing
- Household Appliances

# FS20 Low Force Compression Load Cell

## STANDARD RANGES

Range	Grams-Force
0 to 750	•
0 to 1500	•

## PERFORMANCE SPECIFICATIONS

Supply Voltage: 5.0V, Ambient Temperature: 25°C (unless otherwise specified)

PARAMETERS	MIN	TYP	MAX	UNITS	NOTES
Span	2.85	3	3.15	V	1
Zero Force Output	0.95	1	1.05	V	1
Accuracy (non linearity, hysteresis, and repeatability)		±1		%Span	2
Output Resistance			5	Ω	
Temperature Error – Span	-2.5		2.5	%Span	3
Temperature Error – Zero	-1.5		1.5	%Span	3
Long Term Stability (1 year)		±1		%Span	
Compensated Temperature	0		50	°C	
Operating Temperature	0		70	°C	
Storage Temperature	-20		+85	°C	
Maximum Overload			2.5X	Rated	
Supply Voltage	3.3	5	12	Vdc	
Isolation Resistance (250Vdc)	50			MΩ	
Deflection at Rated Load			0.05	mm	
Humidity	0		90	%RH	
Creep (20 minutes at FS input)		1		%Span	
Weight		5.31		grams	

For custom configurations, consult factory.

### Notes

1. Ratiometric to supply.
2. Best fit straight line
3. Maximum temperature error over compensated range with respect to 25°C.

## CE Compliance

IEC61000-4-2 [4 KV/4 KV (Air/Contact)]

IEC61000-4-3 (3 V/m)

IEC55022 Class A

# FS20 Low Force Compression Load Cell

## DIMENSIONS

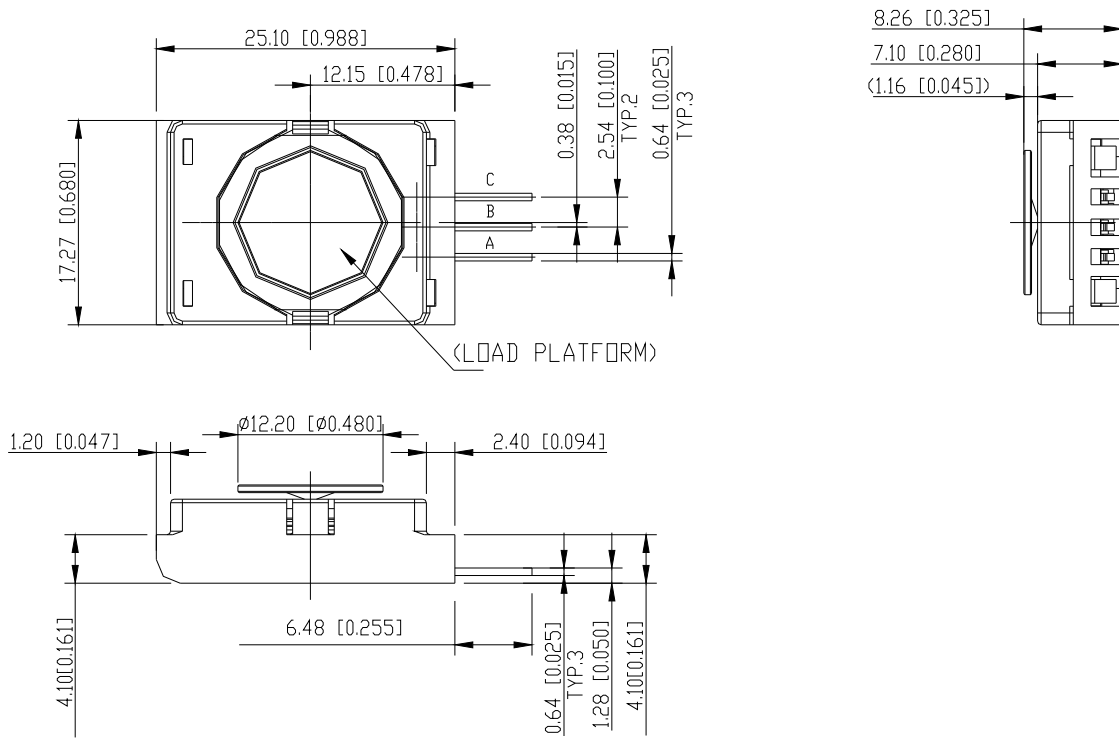

## CONNECTIONS

AMPLIFIED PIN OUT:

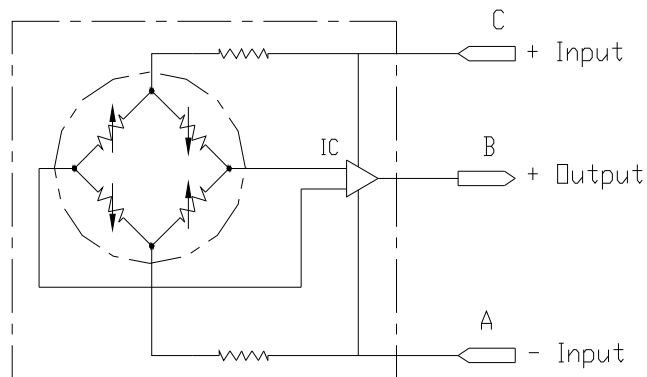

# FS20 Low Force Compression Load Cell

## ORDERING INFORMATION

FS20 5 0 - 0000 - 1500 - G

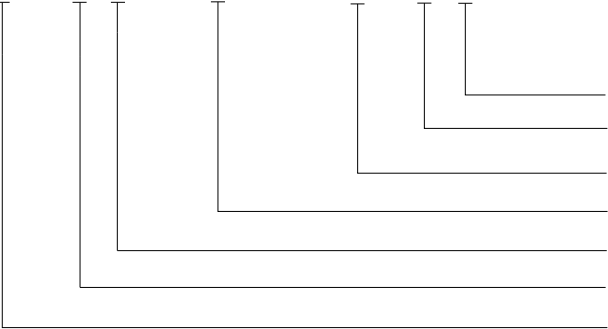

- Units (G = Gram-force)
- Multiplier (- = None)
- Force Range
- Specials (Reserved for Custom Designs)
- Connection (0 = Pin output)
- Output (5 = 1 - 4V)
- Model

## 联系方式



深圳市亿为测控电子有限公司  
Shenzhen Bill-Well Measurement & Control Electronics Co., Ltd.

广东省深圳市南山区创业路怡海广场东座2407 邮编：518000  
电话：+86 755 2641 9890 传真：+86 755 2641 9680  
电子邮箱：sales@bill-well.com