



- Rugged Design for Harsh Environments
- High Burst Pressure Limit
- High Reliability
- Low and High Level Output Signals

DESCRIPTION

The P1200 Series pressure transducers and transmitters provide high accuracy pressure measurement of liquids and gases. These robust transducers combine hybrid electronics with highly reliable strain gauge sensing technology to offer superior performance in rugged applications. Constructed from media compatible 17-4 PH stainless steel, the P1200 provides exceptional performance in extreme environments.

Accuracy of the P1200 is guaranteed to be within $\pm 0.20\%$ F.R.O. over a wide temperature compensated range of -20°C to 80°C . The P1200 is available with either cable or connector terminations or offers a variety of outputs including 0-20 mV, 0-100 mV, 0-5 V and 4-20 mA. Six selectable pressure ports are available to suit most application requirements. Pressure ranges include 0-75 psi to 10,000 psi (0-5 bar to 700 bar) and can be referenced in absolute, sealed or vented gauge. The P1200 Series maintains a high burst rate of greater than 20x the rated pressure and 5x overpressure limit without damage to the sensor due to a positive over travel stop.

For parts requiring RoHS compliance, please contact factory.

FEATURES

- Typical Accuracy of $< \pm 0.15\%$ F.R.O.
- Cable/Connector Termination
- Stainless Steel Media Isolated
- 5x Overpressure Protection
- High and Low Level Output

APPLICATIONS

- Vehicle Brake System Monitoring
- Gas Production
- Farm Machinery
- Hydraulic Control Monitoring

P1200

PERFORMANCE SPECS

Series	P1200	P1230	P1240	P1260	P1280
Model Number	P1221/3	P1231/3	P1241/3	P1261/3	P1281/3
Input Voltage	10VDC (12 V max)	10VDC (12 V max)	10VDC (12 V max)	18-32VDC	10-36VDC
Impedance (ohms)	1000 to 1600	-	-	-	-
Current (mA max)	10	12	12	25	-
Full Range Output (±2%)	20mV	100mV	5VDC	5VDC	4-20 mA (16 mA±2%)
Impedance (ohm)	1000 ±50	<10	<10	<10	Load Resistance 1300 ohm (max) at 36VDC
Current (mA max)	-	-	5	5	-
Frequency Response	2.5 to 40 kHz	2 kHz	2 kHz	1 kHz	1 kHz
Residual Unbalance	<±2	<±2	<±2	<±2	4.0 mA +2-0
Weight oz (gm)	3.4 (95)	4.4 (125)	4.4 (125)	4.4 (125)	4.4 (125)

COMMON SPECIFICATIONS

Pressure Ranges

High (psi)	0-75, 100, 150, 220, 250, 350, 500, 750, 1000, 1500, 2200, 2900, 3500, 5000, 7500, 10,000
(bar)	0-5, 7, 10, 15, 20, 25, 35, 50, 70, 100, 150, 200, 250, 350, 500, 700
DIN (bar)	6, 10, 16, 25, 40, 60, 100, 160, 250, 400, 600

Pressure References Vented gauge (Sensors should only breathe dry noncorrosive gases. Sealed gauge and absolute to special order).

Pressure Limit >5x full range pressure or 12,000 psi (830 bar), whichever is less.

Burst Pressure >20 x full range pressure or 22,000 psi (1,520 bar), whichever is less

Pressure Media Liquids or gases compatible with 17-4 PH stainless steel

Combined Non-linearity, Hysteresis

and Non-repeatability <±0.15% F.R.O. (typ); ±0.20% F.R.O. max (BSL) – high range

Temperature Range

Operable -65°F to 185°F (-54°C to 85°C) [P1221/4 -65°F to 250°F (-54°C to 120°C)]

Compensated -4°F to 185°F (-20°C to 85°C) [P1221/4 -4°F to 212°F (-20°C to 100°C)]

Storage -65°F to 250°F (-54°C to 120°C)

Combined Thermal Zero

And Sensitivity Shift <±0.010% F.R.O./°F (±0.02% F.R.O./°C) over compensated temperature range

Total Thermal Error Band* (including NLH) %F.R.O.

-4° to 185°F (-20° to 85 °C ±1.2% typical, ±2.0% max. (over compensated temperature range)

Shock Resistance 1000 g for 5 msec

Vibration Resistance Surpasses MIL STD810C Method 514-2 Curve L and EUROCAE ED 14A/RTCA 160A

Humidity

Connector Version 95% Relative humidity

Cable Version Immersible to IP67

EMC

Emissions to EN55022 (CISPR 22) Limit B; Radiated Immunity to IEC 801-3 Level 3 10 V/m; Burst Transients to IEC 801-4 Level 3 (2kV); Electrostatic Discharge to IEC 801-2 Level 2 (4kV contact); Surges to IEC 801-5 class 3 (2kV).

Insulation Resistance 500 MOhm at 50 VDC

P1200

DIMENSIONS

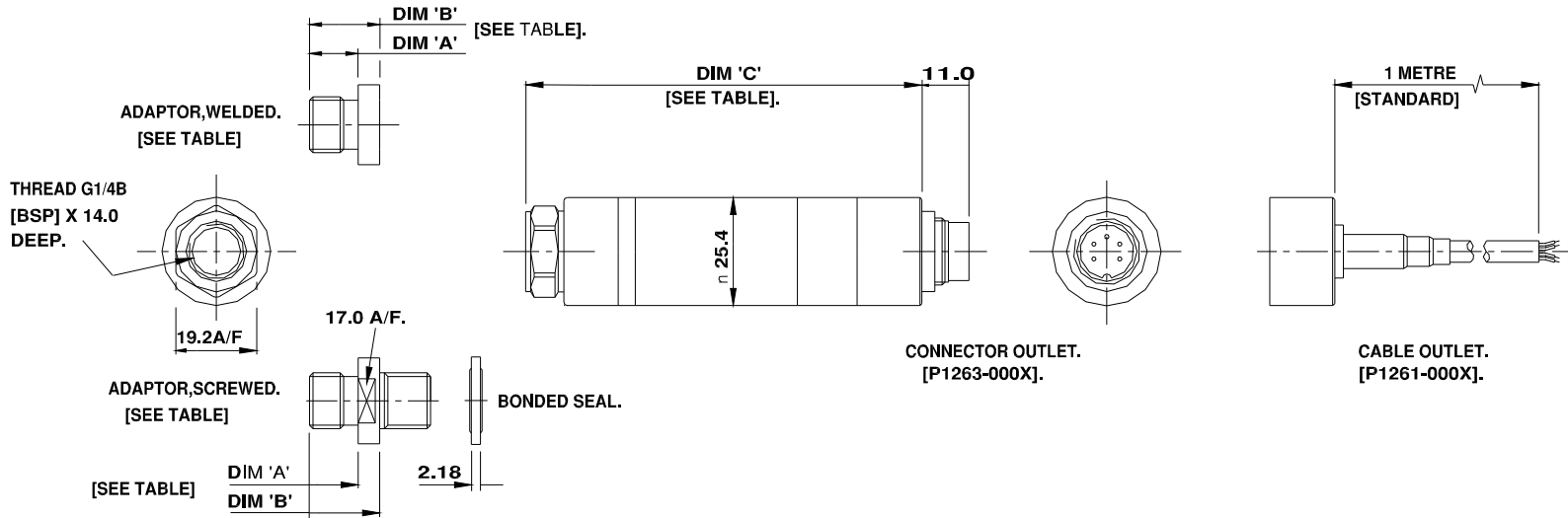

Adapters					
Thread Size	Code Welded	A	B	Code Screw In	B
G1/4A (BSP) (F)	0001				
G1/4A (BSP) (M)	0002	0.46 (11.7)	0.67 (16.9)	0022	0.70 (17.8)
M14 x 1.5 (M)	0003	0.40 (10.2)	0.61 (15.4)	0023	0.62 (15.8)
7/16"-20UNF-2A (M)	0004	0.56 (14.3)	0.77 (19.5)	0024	0.78 (19.8)
1/4"-18NPT (M)	0005	0.67 (17.0)	0.87 (22.2)	0025	0.92 (23.4)
M10 x 1.0 (F)	0006		0.60 (15.2)	0026	0.61 (15.4)
1/4"-18NPT (F)	0009				

	Dimension C	
	0 to 5 - 50 bar	0 to 70 -700 bar
P1221/3-00XX	65.0	66.5
P1231/3-00XX	79.0	80.5
P1241/3-00XX	79.0	80.5
P1261/3-00XX	93.4	95.0
P1281/3-00XX	79.0	80.5

P1200

ORDERING INFORMATION

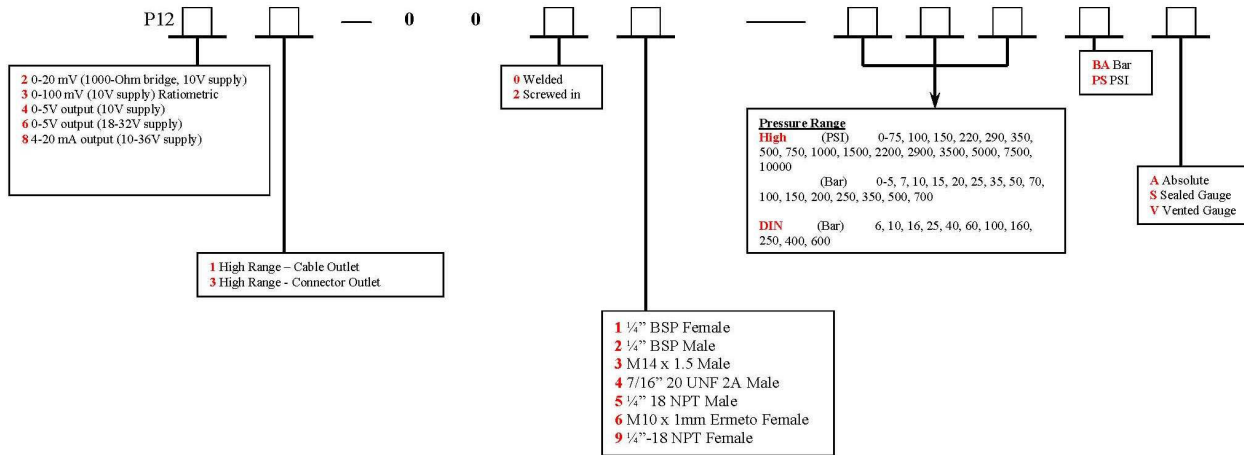

Example: P1283-0023-10KPSS = 4 to 20mA output, connector outlet, screwed in M14 male port, 10,000 psi sealed gauge

联系方式



深圳市亿为测控电子有限公司
Shenzhen Bill-Well Measurement & Control Electronics Co., Ltd.

广东省深圳市南山区创业路怡海广场东座2407 邮编：518000

电话：+86 755 2641 9890 传真：+86 755 2641 9680

电子邮箱：sales@bill-well.com