

85 Flush Mount

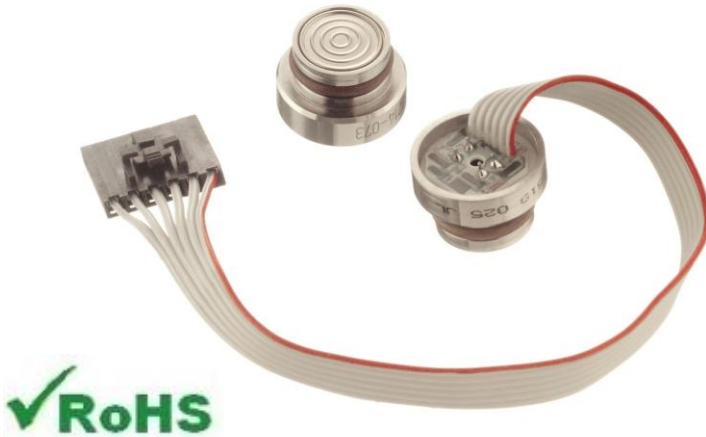

- 316L SS
- Flush Diaphragm
- 0 - 100mV Output
- Absolute and Gage
- Temperature Compensated



DESCRIPTION

The 85 Flush Mount is a small profile, media compatible, piezoresistive silicon pressure sensor packaged in a 316L stainless steel housing. The 85 Flush Mount is designed for o-ring mounting where the diaphragm must not be shrouded by weld ring or fitting.

The sensing package utilizes silicon oil to transfer pressure from the 316L stainless steel diaphragm to the sensing element. A ceramic substrate is attached to the package that contains laser-trimmed resistors for temperature compensation and offset correction. An additional laser trimmed resistor is included which can be used to adjust an external differential amplifier and provide span interchangeability to within $\pm 1\%$.

FEATURES

- O-Ring Flush Mount
- 0°C to 70°C Compensated Temperature Range
- $\pm 0.1\%$ Pressure Non Linearity
- $\pm 0.75\%$ Temperature Performance
- $\pm 1.0\%$ Interchangeable Span (provided by gain set resistor)
- Solid State Reliability

APPLICATIONS

- Dialysis Machines
- Infusion Pumps
- Medical Systems
- Pressure Transmitters
- Level Systems

STANDARD RANGES

Range	psig	psia
0 to 15	•	•
0 to 30	•	•
0 to 50	•	•
0 to 100	•	•
0 to 300	•	•
0 to 500	•	•

PERFORMANCE SPECIFICATIONS

Supply Current: 1.5mA

Ambient Temperature: 25°C (unless otherwise specified)

Parameters are specified for the compensated versions only

PARAMETERS	MIN	TYP	MAX	UNITS	NOTES
Span	65	100	150	mV	1
Zero Pressure Output	-2		2	mV	2
Pressure Non Linearity	-0.1		0.1	%Span	3
Pressure Hysteresis	-0.05		0.05	%Span	
Repeatability		±0.02		%Span	
Input Resistance	2000	3500	5800	Ω	
Output Resistance	4000		6000	Ω	
Temperature Error – Span	-0.75		0.75	%Span	4
Temperature Error – Offset	-0.75		0.75	%Span	4
Thermal Hysteresis – Span	-0.25		0.25	%Span	4
Thermal Hysteresis – Offset	-0.25		0.25	%Span	4
Long Term Stability – Span		±0.1		%Span/year	
Long Term Stability – Offset		±0.1		%Span/year	
Supply Current	0.5	1.5	2.0	mA	5
Output Load Resistance	5			MΩ	6
Insulation Resistance (50Vdc)	50			MΩ	7
Output Noise (10Hz to 1kHz)		1.0		uV p-p	
Response Time (10% to 90%)		1.0		Ms	
Pressure Overload			3X	Rated	8
Pressure Burst			4X	Rated	9
Compensated Temperature	0		70	°C	
Operating Temperature	-20		+125	°C	10
Storage Temperature	-50		+125	°C	10

Media – Pressure Port Liquids and gases compatible with 316/316L Stainless Steel

Notes

1. For amplified output circuits, 3.012V ±% interchangeability with gain set resistor. See Application Schematic.
2. Measured at vacuum for Absolute (A), ambient for Gage (G).
3. Best fit straight line.
4. Over the compensated temperature range with respect to 25°C.
5. Guarantees output/input ratiometricity.
6. Load resistance to reduce measurement errors due to output loading.
7. Between case and sensing element.
8. The maximum temperature range that can be applied without changing the transducer's performance or accuracy.
9. The maximum pressure that can be applied to a transducer without rupture of either the sensing element or transducer.
10. Maximum temperature range for product with standard cable and connector is -20°C to +105°C.

85 Flush Mount

DIMENSIONS

DIMENSIONS ARE IN INCHES [mm]

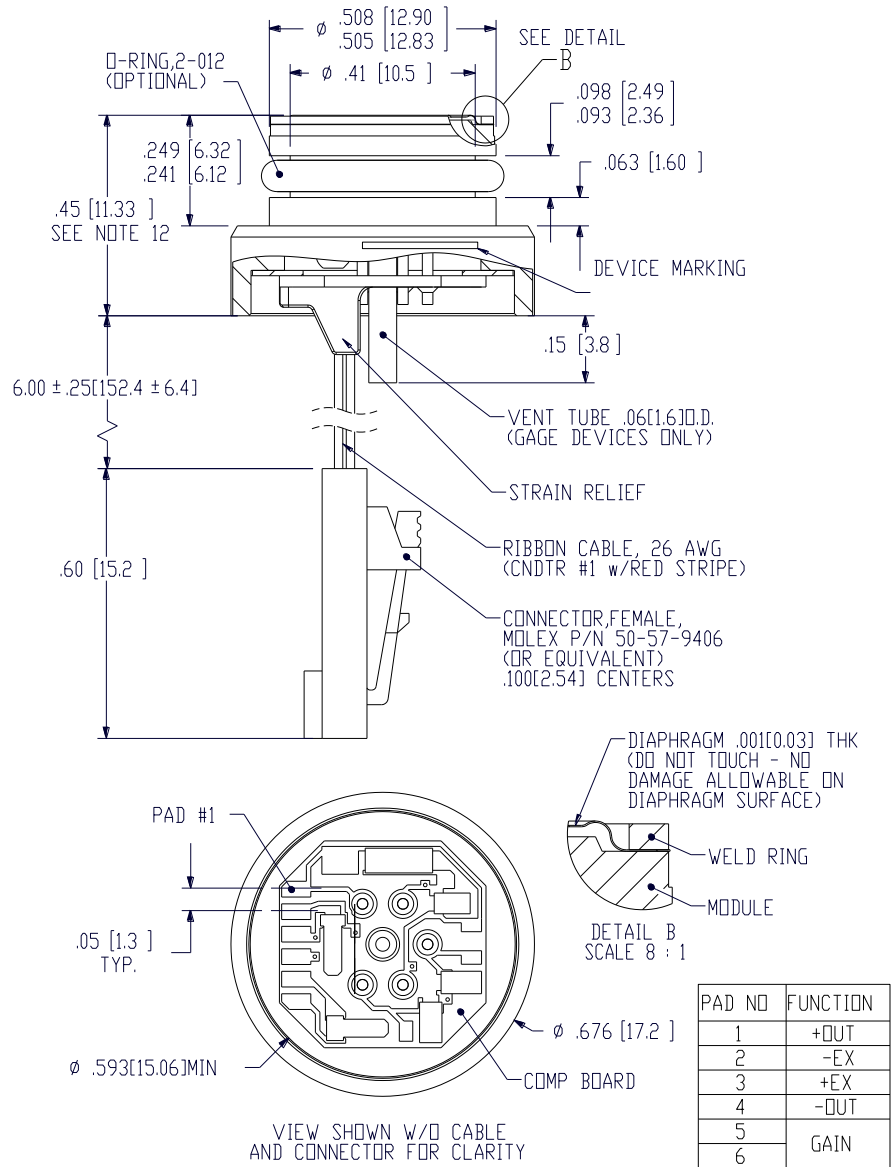

85 Flush Mount

APPLICATION SCHEMATIC

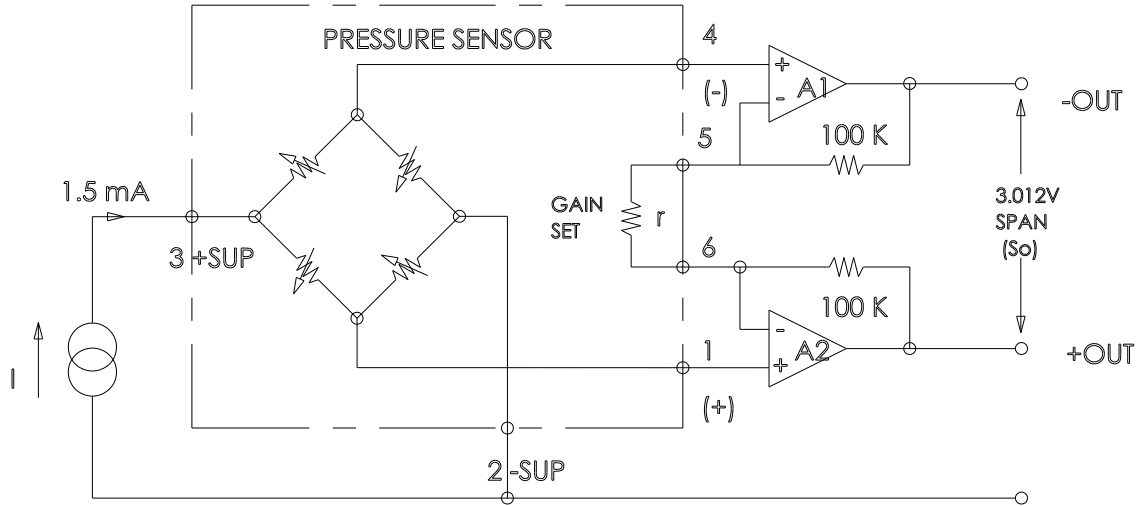

ORDERING INFORMATION

85 - 050 - G - F C T

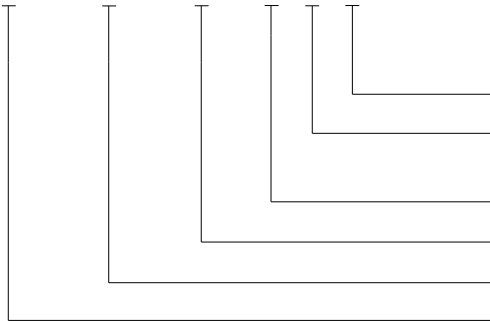

- Vent (T = Tube, Blank = No Tube)
- Electrical (C = Ribbon Cable with Connector, R = Ribbon Cable, P = Solder Pads)
- F = Flush Diagram
- Type (A = Absolute, G = Gage)
- Pressure Range
- Model

联系方式



深圳市亿为测控电子有限公司
Shenzhen Bill-Well Measurement & Control Electronics Co., Ltd.

广东省深圳市南山区创业路怡海广场东座2407 邮编：518000
电话：+86 755 2641 9890 传真：+86 755 2641 9680
电子邮箱：sales@bill-well.com