

## MS5805-02BA01 Miniature Altimeter Module



- High resolution module, 20 cm
- Fast conversion down to 0.5 ms
- Low power, 0.6  $\mu\text{A}$  (standby < 0.15  $\mu\text{A}$  at 25°C)
- Integrated digital pressure sensor (24 bit  $\Delta\Sigma$  ADC)
- Supply voltage 1.8 to 3.6 V
- Operating range: 300 to 1200 mbar, -40 to +85 °C
- Extended pressure range: 10 to 2000 mbar
- I<sup>2</sup>C interface
- No external components (Internal oscillator)
- Excellent long term stability
- Sealing designed for 2.5 x 1mm O-ring

### DESCRIPTION

The MS5805-02BA is a new generation of high-resolution altimeter sensors from MEAS Switzerland with I<sup>2</sup>C bus interface. It is optimized for altimeters and variometers with an altitude resolution of 20 cm. The sensor module includes a high-linearity pressure sensor and an ultra low power 24 bit  $\Delta\Sigma$  ADC with internal factory-calibrated coefficients. It provides a precise digital 24 Bit pressure and temperature value and different operation modes that allow the user to optimize for conversion speed and current consumption. A high-resolution temperature output allows the implementation of an altimeter/thermometer function without any additional sensor. The MS5805-02BA can be interfaced to virtually any microcontroller. The communication protocol is simple, without the need of programming internal registers in the device. This new sensor module generation is based on leading MEMS technology and latest benefits from MEAS Switzerland proven experience and know-how in high volume manufacturing of altimeter modules, which have been widely used for over a decade. The sensing principle employed leads to very low hysteresis and high stability of both pressure and temperature signal.

### FEATURES

#### FIELD OF APPLICATION

Mobile altimeter / barometer systems  
 Bike computers  
 Adventure or multi-mode watches  
 Variometers  
 Dataloggers

#### FUNCTIONAL BLOCK DIAGRAM

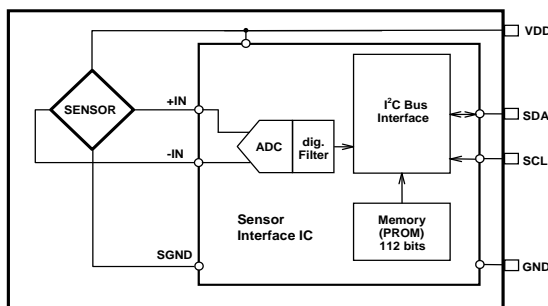

#### TECHNICAL DATA

Sensor Performances ( $V_{DD} = 3\text{ V}$ )				
Pressure	Min	Typ	Max	Unit
Range	10		2000	mbar
ADC	24			bit
Resolution (1)	0.35 / 0.19 / 0.11 / 0.06 / 0.03 / 0.02			mbar
Accuracy 25°C, 750 to 1100 mbar	-2		+2	mbar
Accuracy -20°C to +85°C, 300 to 1200 mbar (2)	-4		+4	mbar
Response time	0.5 / 1.1 / 2.1 / 4.1 / 8.22 / 16.44			ms
Long term stability		$\pm 1$		mbar/yr
Temperature	Min	Typ	Max	Unit
Range	-40		+85	°C
Resolution	<0.01			°C
Accuracy	-1		+1	°C
Notes: (1) Oversampling Ratio: 256 / 512 / 1024 / 2048 / 4096 / 8192 (2) With autozero at one pressure point				

# MS5805-02BA01 Miniature Altimeter Module

## PERFORMANCE SPECIFICATIONS

### ABSOLUTE MAXIMUM RATINGS

Parameter	Symbol	Conditions	Min.	Typ.	Max	Unit
Supply voltage	$V_{DD}$		-0.3		+3.6	V
Storage temperature	$T_S$		-20		+85	°C
Overpressure	$P_{max}$				5	bar
Maximum Soldering Temperature	$T_{max}$	40 sec max			250	°C
ESD rating		Human Body Model	-2		+2	kV
Latch up		JEDEC standard No 78	-100		+100	mA

### ELECTRICAL CHARACTERISTICS

Parameter	Symbol	Conditions	Min.	Typ.	Max	Unit
Operating Supply voltage	$V_{DD}$		1.8	3.0	3.6	V
Operating Temperature	T		-40	+25	+85	°C
Supply current (1 sample per sec.)	$I_{DD}$	OSR	8192	20.09		$\mu$ A
			4096	10.05		
			2048	5.02		
			1024	2.51		
			512	1.26		
256	0.63					
Peak supply current		during conversion		1.25		mA
Standby supply current		at 25°C ( $V_{DD} = 3.0$ V)		0.01	0.1	$\mu$ A
VDD Capacitor		From VDD to GND	100	470		nF

### ANALOG DIGITAL CONVERTER (ADC)

Parameter	Symbol	Conditions	Min.	Typ.	Max	Unit
Output Word				24		bit
Conversion time	$t_c$	OSR	8192	16.44		ms
			4096	8.22		
			2048	4.13		
			1024	2.08		
			512	1.06		
256	0.54					

# MS5805-02BA01 Miniature Altimeter Module

## PERFORMANCE SPECIFICATIONS (CONTINUED)

### PRESSURE OUTPUT CHARACTERISTICS ( $V_{DD} = 3\text{ V}$ , $T = 25^\circ\text{C}$ UNLESS OTHERWISE NOTED)

Parameter	Conditions	Min.	Typ.	Max	Unit
Operating Pressure Range	$P_{\text{range}}$ Full Accuracy	300		1200	mbar
Extended Pressure Range	$P_{\text{ext}}$ Linear Range of ADC	10		2000	mbar
Absolute Accuracy, no autozero	at $25^\circ\text{C}$ , 750..1100 mbar	-2		+2	mbar
Absolute Accuracy, autozero at one pressure point	300..1200 mbar at $25^\circ\text{C}$ 300..1200 mbar, $-20..85^\circ\text{C}$	-2 -4		+2 +4	mbar
Maximum error with supply voltage	$V_{DD} = 1.8\text{ V} \dots 3.6\text{ V}$		$\pm 2.5$		mbar
Long-term stability			$\pm 1$		mbar/yr
Resolution RMS	OSR 8192 4096 2048 1024 512 256		0.02 0.03 0.06 0.11 0.19 0.35		mbar
Reflow soldering impact	IPC/JEDEC J-STD-020C (See application note AN808 on <a href="http://meas-spec.com">http://meas-spec.com</a> )		-1.5		mbar
Recovering time after reflow (1)			5		days

(1) Time to recover at least 66% of the reflow impact.

### TEMPERATURE OUTPUT CHARACTERISTICS ( $V_{DD} = 3\text{ V}$ , $T = 25^\circ\text{C}$ UNLESS OTHERWISE NOTED)

Parameter	Conditions	Min.	Typ.	Max	Unit
Absolute Accuracy	at $25^\circ\text{C}$ $-20..85^\circ\text{C}$	-1 -2		+1 +2	$^\circ\text{C}$
Maximum error with supply voltage	$V_{DD} = 1.8\text{ V} \dots 3.6\text{ V}$		$\pm 0.3$		$^\circ\text{C}$
Resolution RMS (to confirm with measured values)	OSR 8192 4096 2048 1024 512 256		0.002 0.003 0.004 0.006 0.009 0.012		$^\circ\text{C}$

## MS5805-02BA01 Miniature Altimeter Module

### PERFORMANCE SPECIFICATIONS (CONTINUED)

#### DIGITAL INPUTS (SDA, SCL)

Parameter	Symbol	Conditions	Min.	Typ.	Max	Unit
Serial data clock	SCL				400	kHz
Input high voltage	V <sub>IH</sub>		80% V <sub>DD</sub>		100% V <sub>DD</sub>	V
Input low voltage	V <sub>IL</sub>		0% V <sub>DD</sub>		20% V <sub>DD</sub>	V
Input leakage current	I <sub>leak25°C</sub> I <sub>leak85°C</sub>	at 25°C			0.1	μA

#### PRESSURE OUTPUTS (I<sup>2</sup>C, DOUT)

Parameter	Symbol	Conditions	Min.	Typ.	Max	Unit
Output high voltage	V <sub>OH</sub>	I <sub>source</sub> = 0.6 mA	80% V <sub>DD</sub>		100% V <sub>DD</sub>	V
Output low voltage	V <sub>OL</sub>	I <sub>sink</sub> = 0.6 mA	0% V <sub>DD</sub>		20% V <sub>DD</sub>	V
Load capacitance	C <sub>LOAD</sub>			16		pF

## TYPICAL PERFORMANCE CHARACTERISTICS

### PRESSURE AND TEMPERATURE ERROR VS PRESSURE AND TEMPERATURE (Typical values)

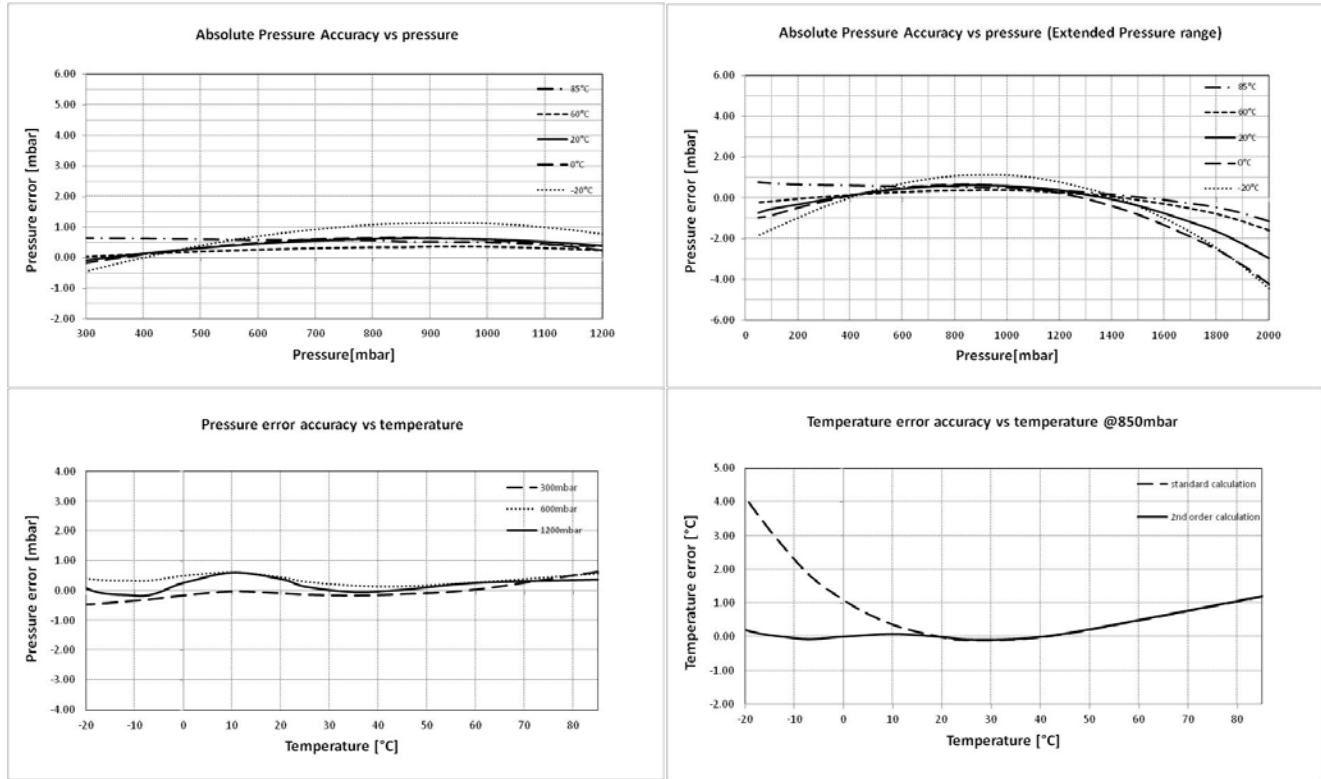

### PRESSURE AND TEMPERATURE ERROR VS POWER SUPPLY (Typical values)

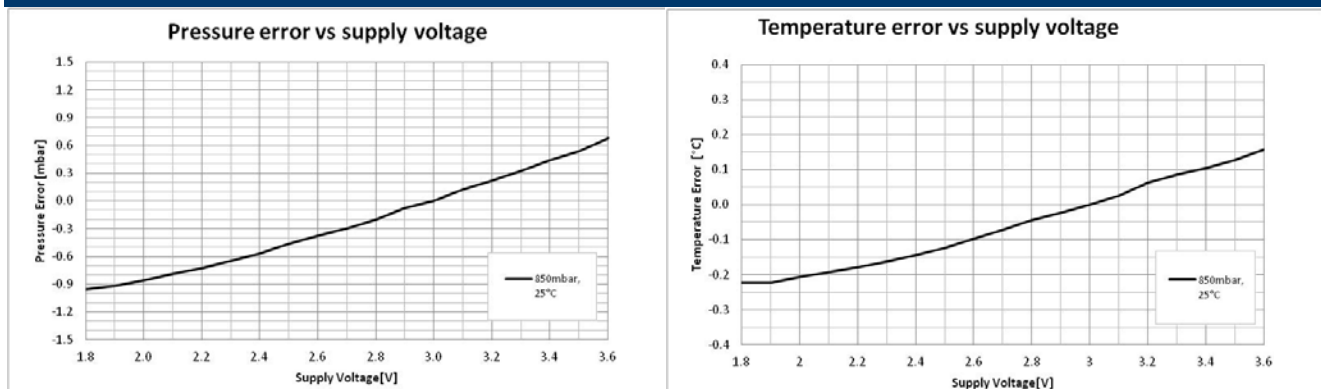

# MS5805-02BA01 Miniature Altimeter Module

## FUNCTIONAL DESCRIPTION

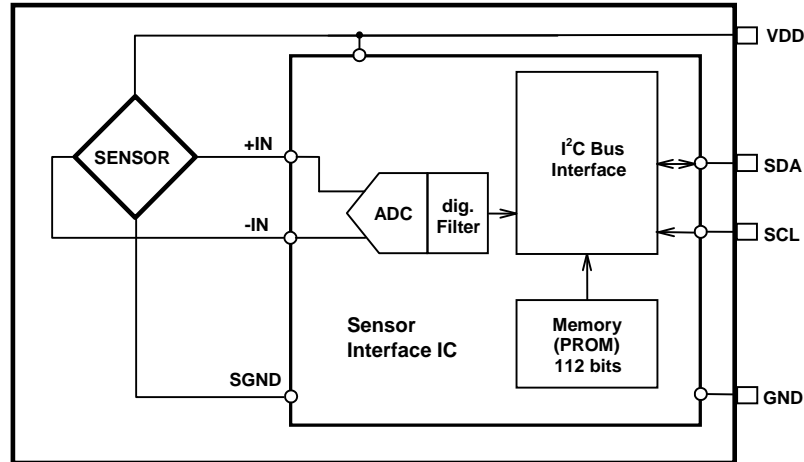

Figure 1: Block diagram of MS5805-02BA

### GENERAL

The MS5805-02BA consists of a piezo-resistive sensor and a sensor interface integrated circuit. The main function of the MS5805-02BA is to convert the uncompensated analogue output voltage from the piezo-resistive pressure sensor to a 24-bit digital value, as well as providing a 24-bit digital value for the temperature of the sensor.

### FACTORY CALIBRATION

Every module is individually factory calibrated at two temperatures and two pressures. As a result, 6 coefficients necessary to compensate for process variations and temperature variations are calculated and stored in the 112-bit PROM of each module. These bits (partitioned into 6 coefficients) must be read by the microcontroller software and used in the program converting D1 and D2 into compensated pressure and temperature values.

### COMMUNICATION INTERFACE

The MS5805-02BA has been built with I<sup>2</sup>C serial interface.

Module ref	Mode	Pins used
MS5805-02BA01	I <sup>2</sup> C	SDA, SCL

The external microcontroller clocks in the data through the input SCL (Serial CLock) and SDA (Serial DAta). The sensor responds on the same pin SDA which is bidirectional for the I<sup>2</sup>C bus interface. So this interface type uses only 2 signal lines and does not require a chip select.

# MS5805-02BA01 Miniature Altimeter Module

## PRESSURE AND TEMPERATURE CALCULATION

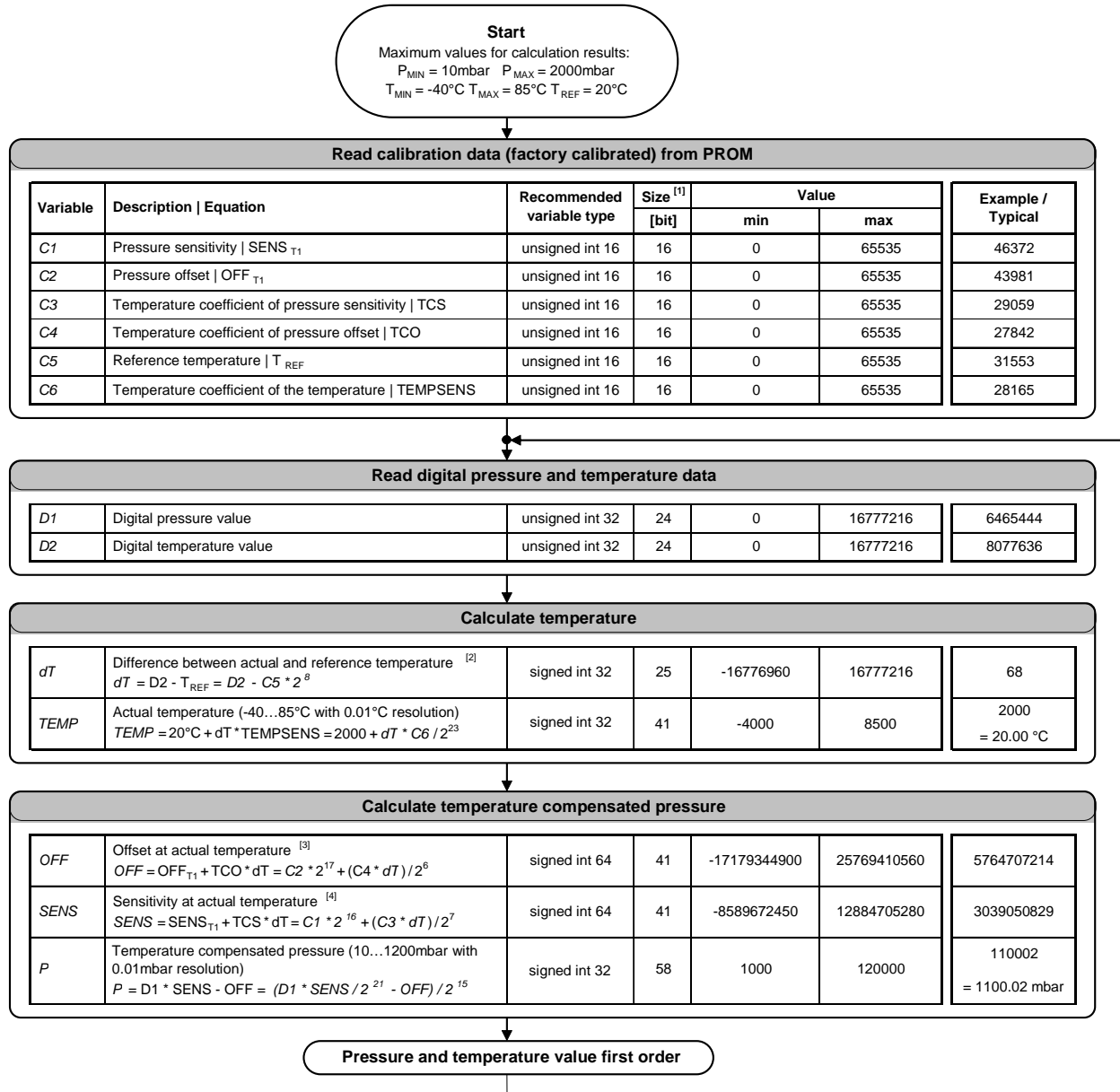

Notes

- [1] Maximal size of intermediate result during evaluation of variable
- [2] min and max have to be defined
- [3] min and max have to be defined
- [4] min and max have to be defined

Figure 2: Flow chart for pressure and temperature reading and software compensation.

## SECOND ORDER TEMPERATURE COMPENSATION

The results of the last first order calculation are entered in the following chart to obtain the pressure and temperature compensated with the 2<sup>nd</sup> order: P2 and TEMP2.

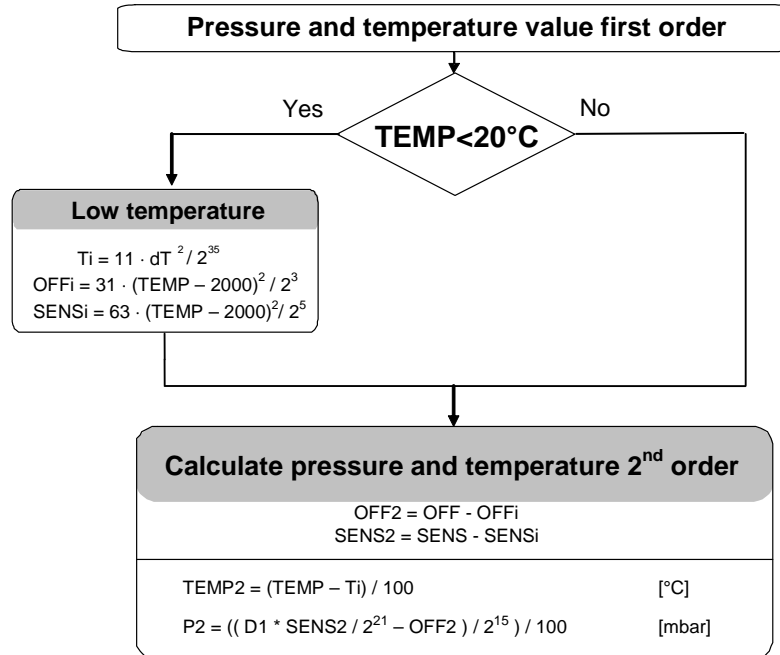

Figure 3: Flow chart for pressure and temperature to the optimum accuracy.



# MS5805-02BA01 Miniature Altimeter Module

## I<sup>2</sup>C INTERFACE

### COMMANDS

The MS5805-02BA has only five basic commands:

1. Reset
2. Read PROM (112 bit of calibration words)
3. D1 conversion
4. D2 conversion
5. Read ADC result (24 bit pressure / temperature)

Each I<sup>2</sup>C communication message starts with the start condition and it is ended with the stop condition. The MS5805-02BA address is 1110110x (write : x=0, read : x=1).

Size of each command is 1 byte (8 bits) as described in the table below. After ADC read commands the device will return 24 bit result and after the PROM read 16bit result. The address of the PROM is embedded inside of the PROM read command using the a2, a1 and a0 bits.

Bit number	Command byte								hex value
	0	1	2	3	4	5	6	7	
Bit name	PRO M	CO NV	-	Typ	Ad2/ Os2	Ad1/ Os1	Ad0/ Os0	Stop	
Command									
Reset	0	0	0	1	1	1	1	0	0x1E
Convert D1 (OSR=256)	0	1	0	0	0	0	0	0	0x40
Convert D1 (OSR=512)	0	1	0	0	0	0	1	0	0x42
Convert D1 (OSR=1024)	0	1	0	0	0	1	0	0	0x44
Convert D1 (OSR=2048)	0	1	0	0	0	1	1	0	0x46
Convert D1 (OSR=4096)	0	1	0	0	1	0	0	0	0x48
Convert D1 (OSR=8192)	0	1	0	0	1	0	1	0	0x4A
Convert D2 (OSR=256)	0	1	0	1	0	0	0	0	0x50
Convert D2 (OSR=512)	0	1	0	1	0	0	1	0	0x52
Convert D2 (OSR=1024)	0	1	0	1	0	1	0	0	0x54
Convert D2 (OSR=2048)	0	1	0	1	0	1	1	0	0x56
Convert D2 (OSR=4096)	0	1	0	1	1	0	0	0	0x58
Convert D2 (OSR=8192)	0	1	0	1	1	0	1	0	0x5A
ADC Read	0	0	0	0	0	0	0	0	0x00
PROM Read	1	0	1	0	Ad2	Ad1	Ad0	0	0xA0 to 0xAE

Figure 4: Command structure

# MS5805-02BA01 Miniature Altimeter Module

## RESET SEQUENCE

The Reset sequence shall be sent once after power-on to make sure that the calibration PROM gets loaded into the internal register. It can be also used to reset the device PROM from an unknown condition.

The reset can be sent at any time. In the event that there is not a successful power on reset this may be caused by the SDA being blocked by the module in the acknowledge state. The only way to get the MS5805 to function is to send several SCLs followed by a reset sequence or to repeat power on reset.

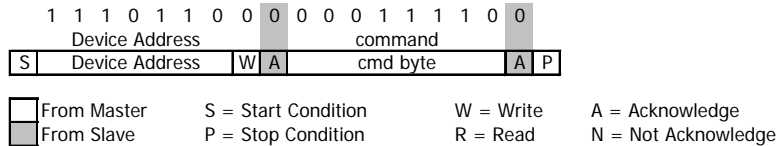

Figure 5: I<sup>2</sup>C Reset Command

## PROM READ SEQUENCE

The read command for PROM shall be executed once after reset by the user to read the content of the calibration PROM and to calculate the calibration coefficients. There are in total 7 addresses resulting in a total memory of 112 bit. Addresses contains factory data and the setup, calibration coefficients, the serial code and CRC. The command sequence is 8 bits long with a 16 bit result which is clocked with the MSB first. The PROM Read command consists of two parts. First command sets up the system into PROM read mode. The second part gets the data from the system.

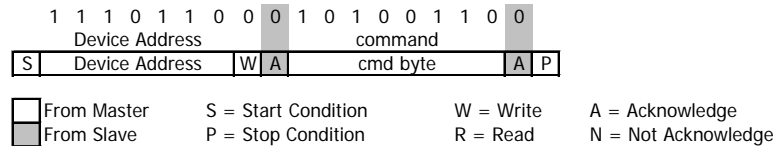

Figure 6: I<sup>2</sup>C Command to read memory address= 011

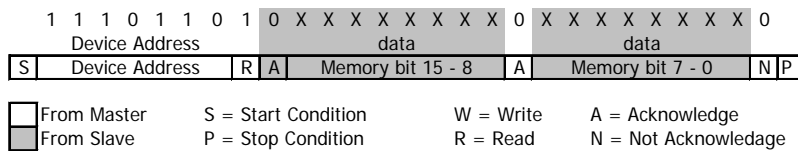

Figure 7: I<sup>2</sup>C answer from MS5805

# MS5805-02BA01 Miniature Altimeter Module

## CONVERSION SEQUENCE

The conversion command is used to initiate uncompensated pressure (D1) or uncompensated temperature (D2) conversion. After the conversion, using ADC read command the result is clocked out with the MSB first. If the conversion is not executed before the ADC read command, or the ADC read command is repeated, it will give 0 as the output result. If the ADC read command is sent during conversion the result will be 0, the conversion will not stop and the final result will be wrong. Conversion sequence sent during the already started conversion process will yield incorrect result as well. A conversion can be started by sending the command to MS5805. When command is sent to the system it stays busy until conversion is done. When conversion is finished the data can be accessed by sending a Read command, when an acknowledge is sent from the MS5805, 24 SCL cycles may be sent to receive all result bits. Every 8 bits the system waits for an acknowledge signal.

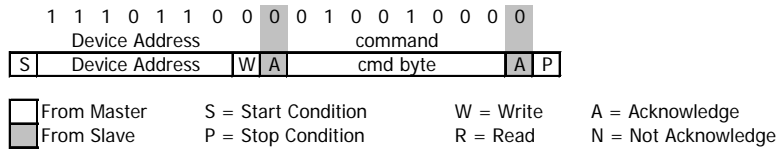

Figure 8: I<sup>2</sup>C command to initiate a pressure conversion (OSR=4096, typ=D1)

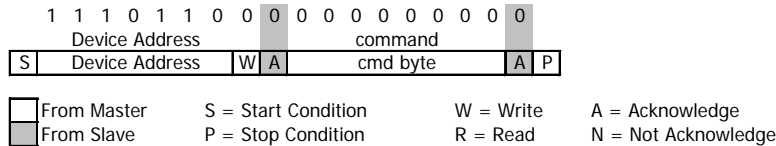

Figure 9: I<sup>2</sup>C ADC read sequence

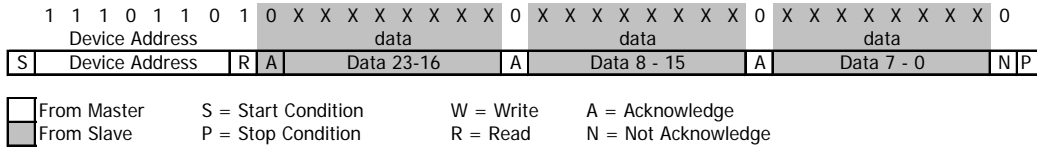

Figure 10: I<sup>2</sup>C answer from MS5805

## CYCLIC REDUNDANCY CHECK (CRC)

MS5805-02BA contains a PROM memory with 112-Bit. A 4-bit CRC has been implemented to check the data validity in memory. The application note AN520 describes in detail CRC-4 code used.

A	D	D	D	D	D	D	D	D	D	D	D	D	D	D	D	D	D
d	B	B	B	B	B	B	B	B	B	B	B	B	B	B	B	B	B
d	1	1	1	1	1	1	1	9	8	7	6	5	4	3	2	1	0
0	CRC				Factory defined												
1	C1																
2	C2																
3	C3																
4	C4																
5	C5																
6	C6																

Figure 11: Memory PROM mapping

# MS5805-02BA01 Miniature Altimeter Module

## APPLICATION CIRCUIT

The MS5805-02BA is a circuit that can be used in conjunction with a microcontroller in mobile altimeter applications. It is designed for low-voltage systems with a supply voltage of 3 V.

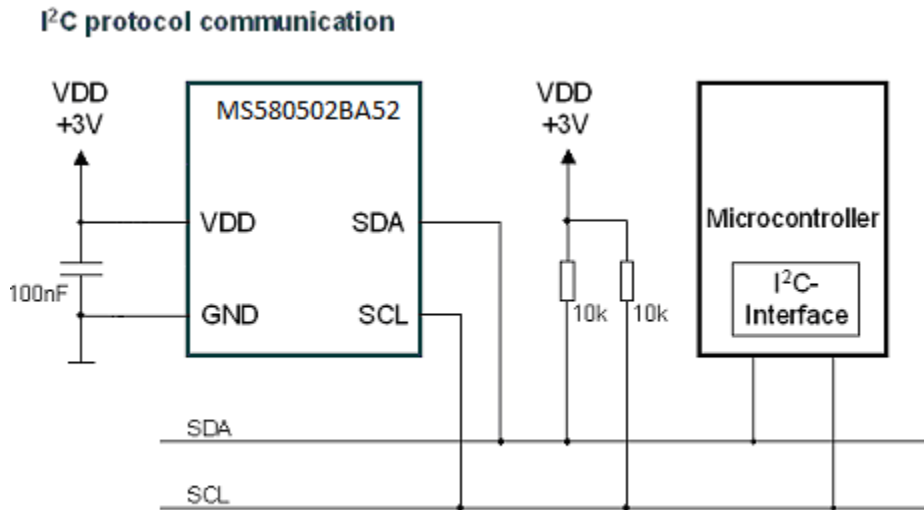

Figure 12: Typical application circuit with I<sup>2</sup>C protocol communication

# MS5805-02BA01 Miniature Altimeter Module

## PIN CONFIGURATION

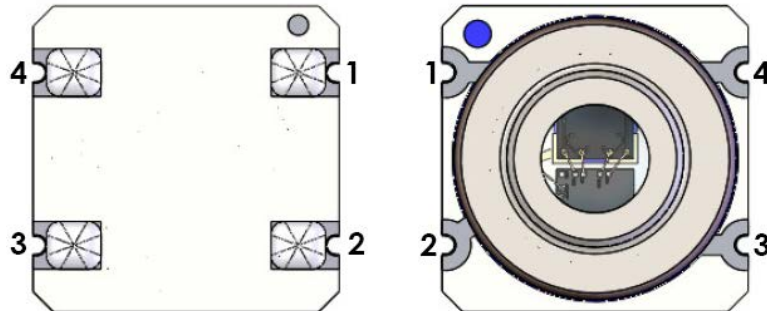

Figure 13: pin configuration

Pin	Name	Type	Function
1	VDD	P	Positive supply voltage
2	SCL	I	Serial data Clock
3	SDA	IO	I <sup>2</sup> C data IO
4	GND	P	Ground

## DEVICE PACKAGE OUTLINE

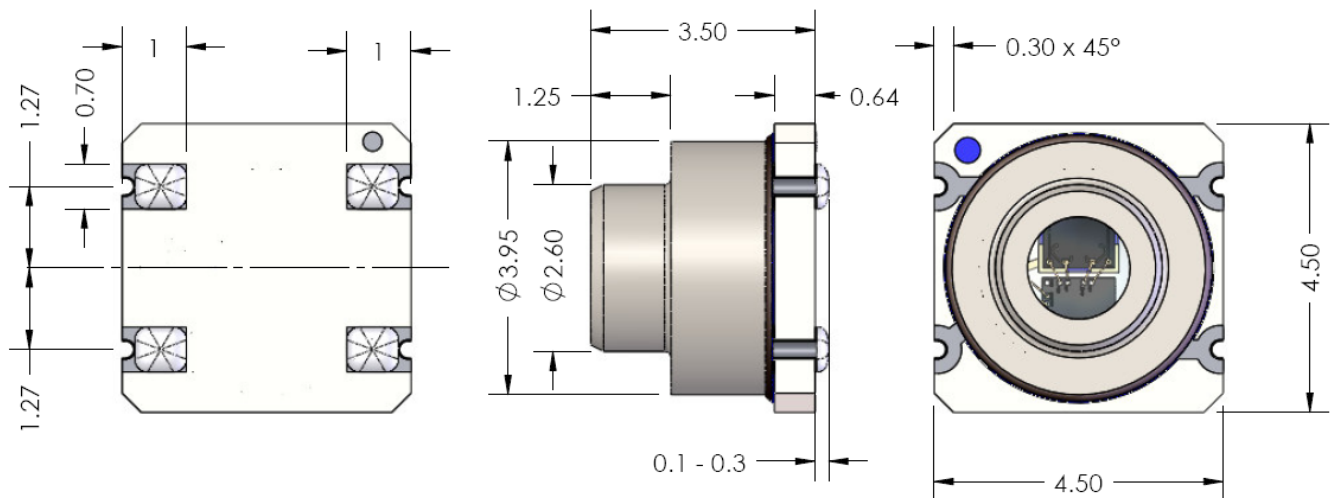

Figure 14: MS5805-02BA package outlines

- Notes:**
- (1) Dimensions in mm
  - (2) Interpret Dim and tolerance per ASME Y14.5M - 1994
  - (3) Angular dimensions  $\pm 0.3^\circ$
  - (4) Hole locations  $\pm 0.1$
  - (4) Linear dimension  $\pm 0.1$
  - (5) Cap centering  $\pm 0.15$  from center of the ceramic

# MS5805-02BA01 Miniature Altimeter Module

## RECOMMENDED PAD LAYOUT

Pad layout for bottom side of the MS5805 soldered onto printed circuit board.

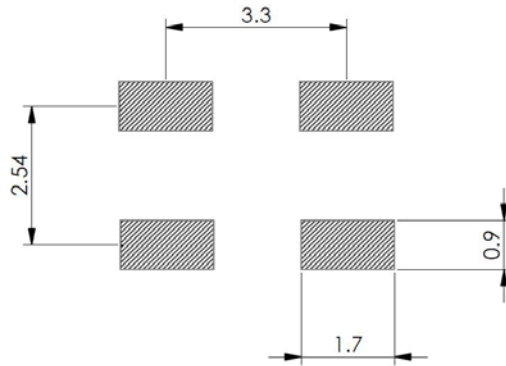

Figure 15: MS5805 pad layout

## SHIPPING PACKAGE

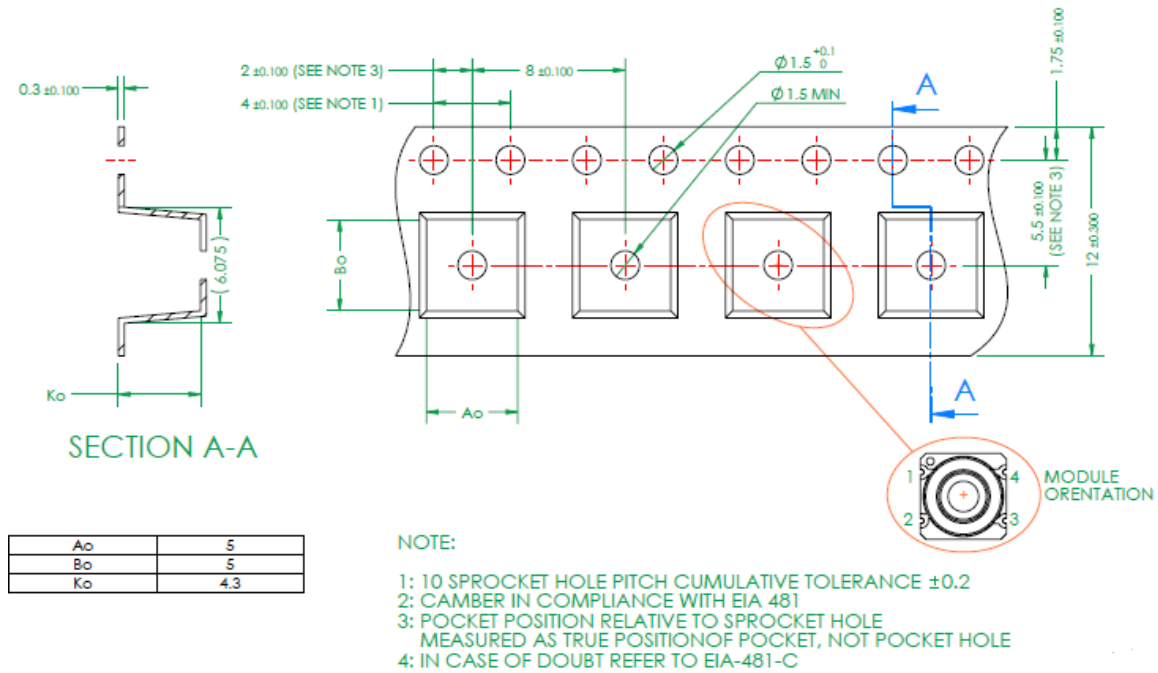

Figure 16: Tape and Reel

# MS5805-02BA01 Miniature Altimeter Module

---

## MOUNTING AND ASSEMBLY CONSIDERATIONS

---

### SOLDERING

Please refer to the application note AN808 available on our website for all soldering issues.

### CONNECTION TO PCB

The package outline of the module allows the use of a flexible PCB for interconnection. This can be important for applications in watches and other special devices.

### CLEANING

The MS5805-02BA has been manufactured under cleanroom conditions. It is therefore recommended to assemble the sensor under class 10'000 or better conditions. Should this not be possible, it is recommended to protect the sensor opening during assembly from entering particles and dust. To avoid cleaning of the PCB, solder paste of type "no-clean" shall be used. Cleaning might damage the sensor!

### ESD PRECAUTIONS

The electrical contact pads are protected against ESD up to 2 kV HBM (human body model). It is therefore essential to ground machines and personnel properly during assembly and handling of the device. The MS5805-02BA is shipped in antistatic transport boxes. Any test adapters or production transport boxes used during the assembly of the sensor shall be of an equivalent antistatic material.

### DECOUPLING CAPACITOR

Particular care must be taken when connecting the device to the power supply. A 100 nF ceramic capacitor must be placed as close as possible to the MS5805-02BA VDD pin. This capacitor will stabilize the power supply during data conversion and thus, provide the highest possible accuracy.

# MS5805-02BA01 Miniature Altimeter Module

## ORDERING INFORMATION

Product Code	Product	Art. No	Delivery form
MS580502BA01	Miniature Altimeter Module, I2C serial communication	MS580502BA01-50	Tape and reel

## 联系方式



深圳市亿为测控电子有限公司  
Shenzhen Bill-Well Measurement & Control Electronics Co., Ltd.

广东省深圳市南山区创业路怡海广场东座2407 邮编：518000

电话：+86 755 2641 9890 传真：+86 755 2641 9680

电子邮箱：sales@bill-well.com