

379 Cable Assembly

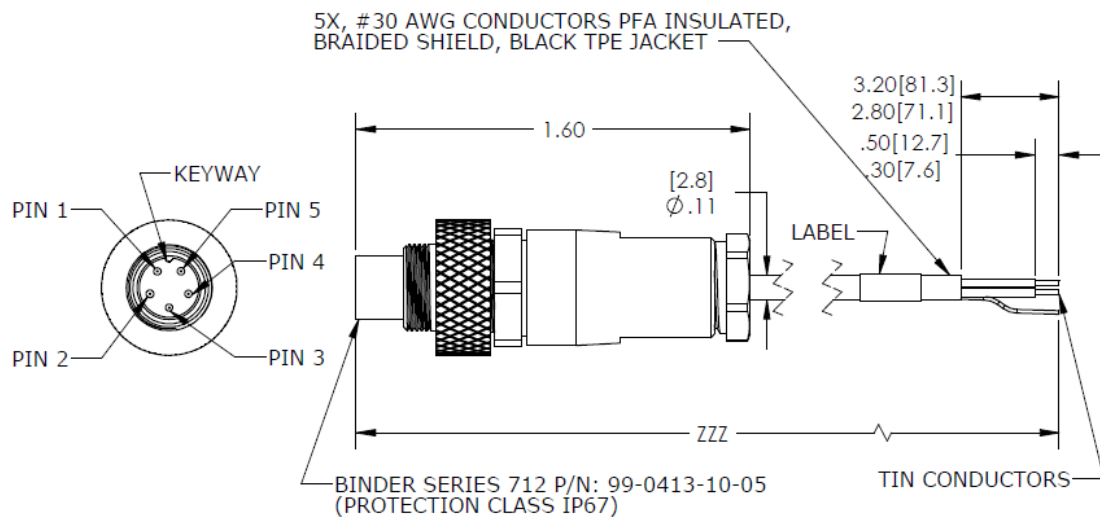

DIMENSIONS



DESCRIPTION

Instrumentation cable for the model 140 & 142 in-line amplifiers. Featuring shielded model 712 series Binder connector to pigtail leads. Standard cable length is 120 inches.

FEATURES

- TPE Jacket
- PFA Insulated #30 AWG Conductors
- SPC Braided Shield
- Shielded Connector
- 40°C to +85°C Temp Range

APPLICATIONS

- In-line Amplifiers
- Laboratory Testing
- Vibration Monitoring
- General Purpose

379 Cable Assembly

ORDERING CODE

379-ZZZ (-ZZZ designates length in inches, -120 standard)

联系方式



深圳市亿为测控电子有限公司
Shenzhen Bill-Well Measurement & Control Electronics Co., Ltd.

广东省深圳市南山区创业路怡海广场东座2407 邮编：518000

电话：+86 755 2641 9890 传真：+86 755 2641 9680

电子邮箱：sales@bill-well.com