

Model 801X-AR/-AP Accelerometer



4-20mA Loop Power
 True RMS or Peak Output
 -40°C to +85°C Operating Range
 Top Exit Connector or Integral Cable



The Model 8011 & 8012 are internally shielded rugged 4-20mA accelerometers. The accelerometers are available in ranges from $\pm 5g$ to $\pm 50g$, in either RMS or Peak acceleration output options. The model 8011 features a top exit MIL-C-5015 connector while the model 8012 features an integral cable. The units are hermetically sealed and are designed for operating in temperature ranges from -40°C to +85°C.

FEATURES

- $\pm 5g$ to $\pm 50g$ Dynamic Range
- 10-5000Hz Bandwidth
- Case Isolated, Internally Shielded
- Hermetically Sealed, Welded
- Annular Shear Mode
- Reverse Wiring Protection
- Stable Temperature Response
- 2-Pin MIL-C-5015 Connector

APPLICATIONS

- General Purpose
- Machine Monitoring
- Rotary Compressors
- Motors and Pumps
- Rotating Machinery

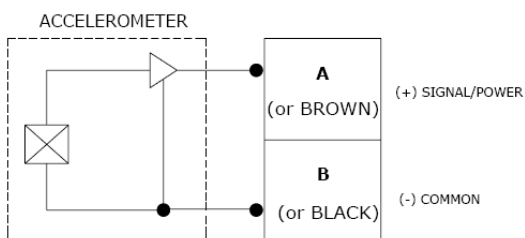

dimensions

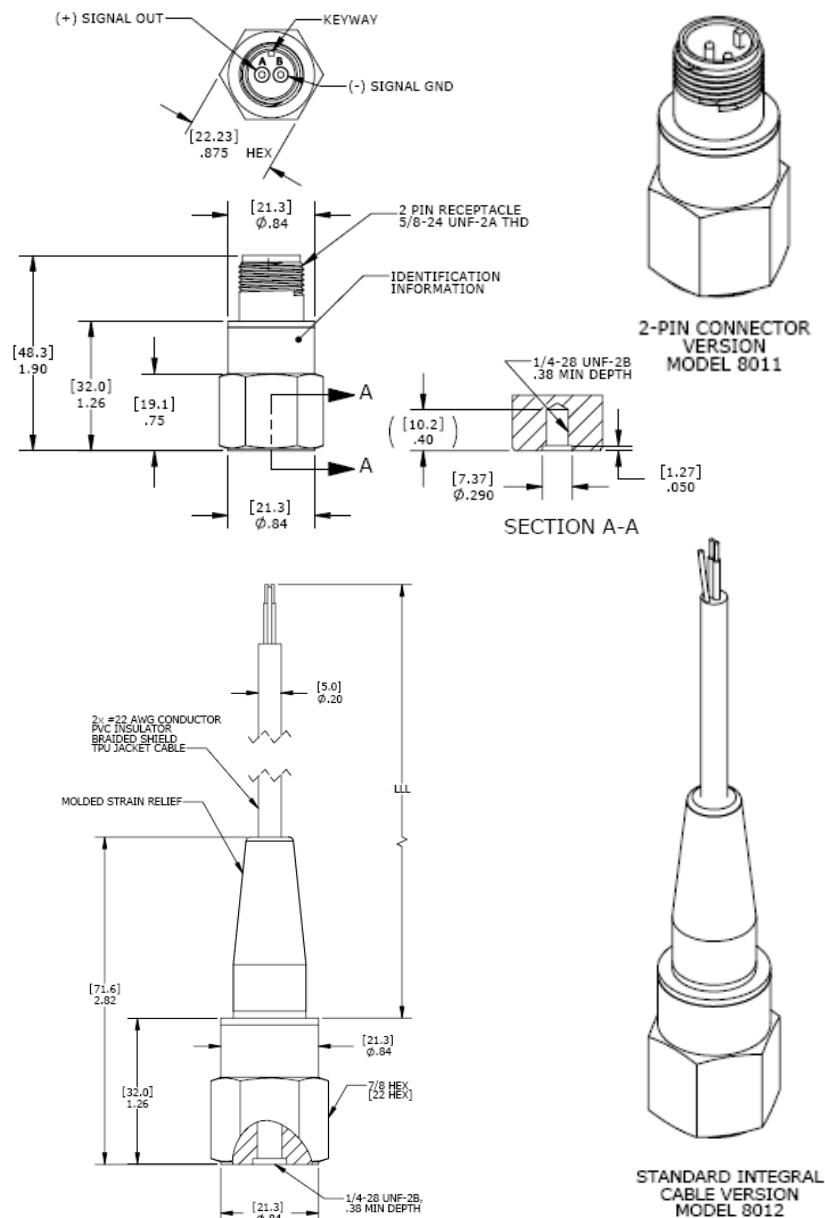

Model 801X-AR/-AP Accelerometer

All values are typical at +24°C, 100Hz and 15Vdc excitation unless otherwise stated. Measurement Specialties reserves the right to update and change these specifications without notice. Standard product parameters are described in PSC-1003 for Plug & Play AC Accelerometers.

Parameters

DYNAMIC					Notes
Range (g Peak or RMS)	±5	±10	±20	±50	
Output (mA)	4 to 20	4 to 20	4 to 20	4 to 20	
Frequency Response (cpm)	600-300000	600-300000	600-300000	600-300000	±10%
Frequency Response (Hz)	10-5000	10-5000	10-5000	10-5000	±10%
Non-Linearity (%FSO)	±1	±1	±1	±1	
Transverse Sensitivity (%)	<5	<5	<5	<5	
Shock Limit (g)	5000	5000	5000	5000	

ELECTRICAL

Excitation Voltage (Vdc)	12 to 30	
Loop Resistance (Ohms)	900 max	See Note 1
Turn on Time (sec)	<10	
Grounding	Case Isolated, Internally Shielded	

ENVIRONMENTAL

Operating Temperature (°C)	-40 to +85
Storage Temperature (°C)	-40 to +85

PHYSICAL

Sensing Element	Ceramic (shear mode)
Case Material	Stainless Steel
Weight (grams)	93
Mounting Torque	24 lb-in (2.7 N-m)

Calibration supplied: CS-FREQ-0100 NIST Traceable Amplitude Calibration from 20Hz to ±10% Frequency Response Limit

Supplied accessories: AC-A03663 ¼-28 to ¼-28 mounting stud

Optional accessories: 316-XXX Cable Assembly, Straight (XXX designates length in inches, 10ft standard)
318-XXX Cable Assembly, 90 Degrees (XXX designates length in inches, 10ft standard)
AC-D03664 ¼-28 to M5 mounting stud
AC-D03665 ¼-28 to M6 mounting stud
AC-A04209 Magnetic Mounting Adaptor

Note 1

Maximum Loop Resistance = (Excitation Voltage – 12Vdc) / 20mA

ordering info

PART NUMBERING Model Number+Range

801X-ZZ-GGG-CCC

| | | | Cable length (120 is 120 inches)
| | | Range (050 is 50g)
| | Range Type (AR is RMS Acceleration)
| Electrical Connection Option (1 for 2-pin connector, 2 for integral cable)

-ZZ

AR = RMS

AP = Peak

Example: 8011-AR-050

Model 8011, 2-pin connector, RMS acceleration output, 50g range

联系方式



深圳市亿为测控电子有限公司
Shenzhen Bill-Well Measurement & Control Electronics Co., Ltd.

广东省深圳市南山区创业路怡海广场东座2407 邮编：518000

电话：+86 755 2641 9890 传真：+86 755 2641 9680

电子邮箱：sales@bill-well.com