

# Model 7514A Accelerometer



+260°C Charge Output Accelerometer  
50pC/g output, 14kHz Bandwidth  
Hermetically Sealed  
Stud Mount, Side Connector



The **Model 7514A** is a stud mounted piezoelectric charge mode accelerometer with an operating temperature range to +260°C. The accelerometer is designed for high frequency vibration and shock measurements and offers a wide bandwidth to >14kHz with a nominal charge output of 50pC/g. The model 7514A features a hermetically sealed stainless steel housing and a #10-32 stud mount configuration.

## FEATURES

- 13pC/g to 50pC/g Sensitivity
- Wide bandwidth up to >14kHz
- Stud Mounted
- Hermetically Sealed
- Annular Shear Mode
- -73°C to +260°C Operating Range
- Stable Temperature Response

## APPLICATIONS

- Vibration & Shock Monitoring
- High Temp Applications
- Laboratory Testing
- High Frequency Applications
- Gearbox Vibration Monitoring

## dimensions

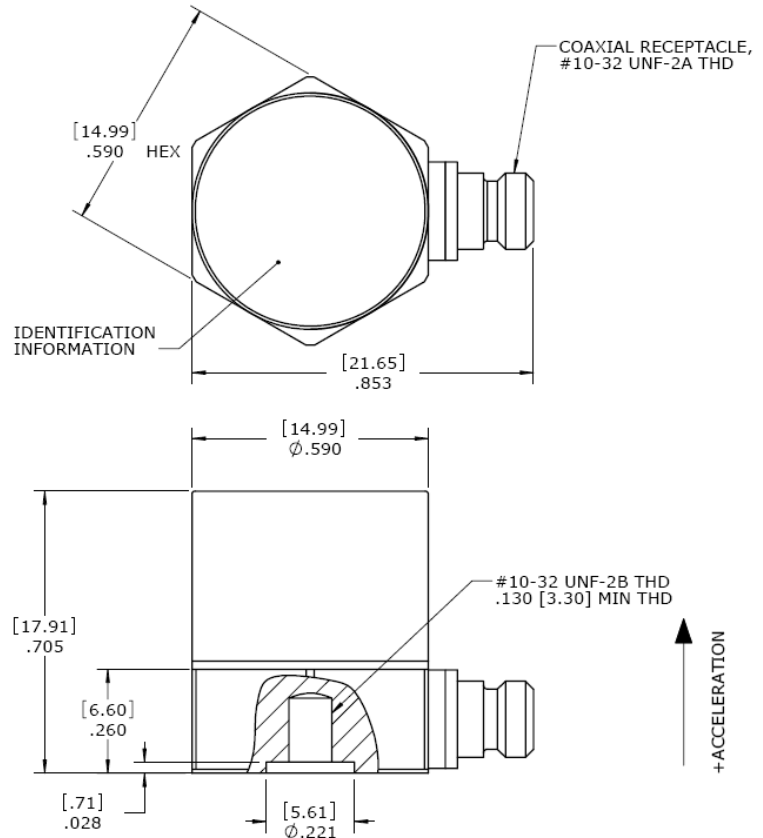

## ACCELEROMETER

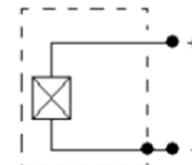

# Model 7514A Accelerometer

## performance specifications

All values are typical at +24°C, 100Hz unless otherwise stated. Measurement Specialties reserves the right to update and change these specifications without notice. Standard product parameters are described in PSC-1003 for Plug & Play AC Accelerometers.

### Parameters

#### DYNAMIC

	-50	-30	-20	-13	Notes
Dash Number	50	30	20	13	Typical
Sensitivity (pC/g)	40	24	14.5	9.0	Minimum
Frequency Response (Hz) <sup>2</sup>	0.5-6000	0.5-7000	0.5-9000	0.5-11000	±10%
Frequency Response (Hz) <sup>2</sup>	0.1-9000	0.1-10000	0.1-12000	0.1-14000	±2dB
Natural Frequency (Hz)	26000	28000	30000	33000	
Non-Linearity (%FSO)	±1/1000g	±1/1000g	±1/1000g	±1/1000g	
Transverse Sensitivity (%)	<5	<5	<5	<5	
Dynamic Range (g) <sup>1</sup>	±500	±800	±1250	±2000	
Shock Limit (g)	10000	10000	10000	10000	

#### ELECTRICAL

Capacitance (pF)	1050	1050	1050	1050	Nominal
Insulation Resistance (MΩ)	>100	>100	>100	>100	@100Vdc
Grounding	Case Grounded				

#### ENVIRONMENTAL

Temperature Response (%)	See Typical Temperature Response Curve
Operating Temperature (°C)	-73 to +260
Storage Temperature (°C)	-73 to +260
Humidity	Hermetically Sealed

#### PHYSICAL

Sensing Element	Ceramic (shear mode)
Case Material	Stainless Steel
Electrical Connector	10-32 Coaxial Receptacle
Weight (grams)	19
Mounting	#10-32 to #10-32 Mounting Stud (included)
Mounting Torque	18 lb-in (2.0 N-m)

<sup>1</sup> Operating range over which the accelerometer meets the linearity specifications

<sup>2</sup> Low-end response of the accelerometer is a function of its associated electronics.

<b>Calibration supplied:</b>	CS-FREQ-0100	NIST Traceable Amplitude Calibration from 20Hz to ±2dB Frequency Response Limit
<b>Supplied accessories:</b>	AC-D02298	10-32 to 10-32 mounting stud
<b>Optional accessories:</b>	320-XXX 324-XXX 130 161A AC-D03105 AC-D03106	Cable Assembly, 10-32 to 10-32 (XXX designates length in inches, 10ft standard) Cable Assembly, 10-32 to BNC (XXX designates length in inches, 10ft standard) In-Line Charge Converter 4-Channel PE & IEPE Signal Conditioner Adhesive Mounting Adaptor Magnetic Mounting Adaptor

## ordering info

PART NUMBERING Model Number+Sensitivity

7514A-GG  
|  
| \_\_\_\_\_ (50 is 50pC/g)

Example: 7514A-50  
Model 7514A, 50pC/g

# Model 7514A Accelerometer

## performance specifications

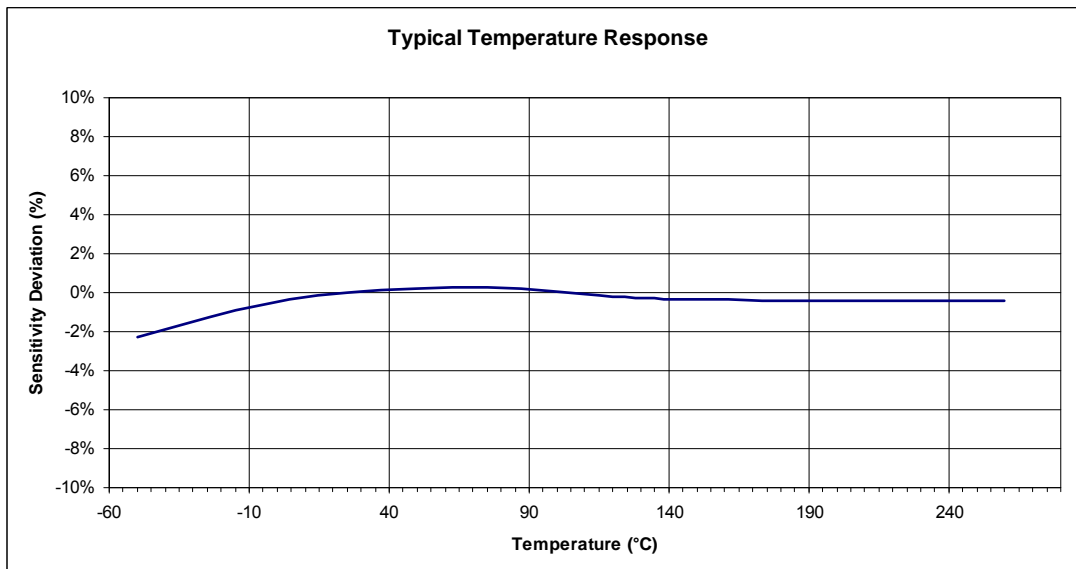
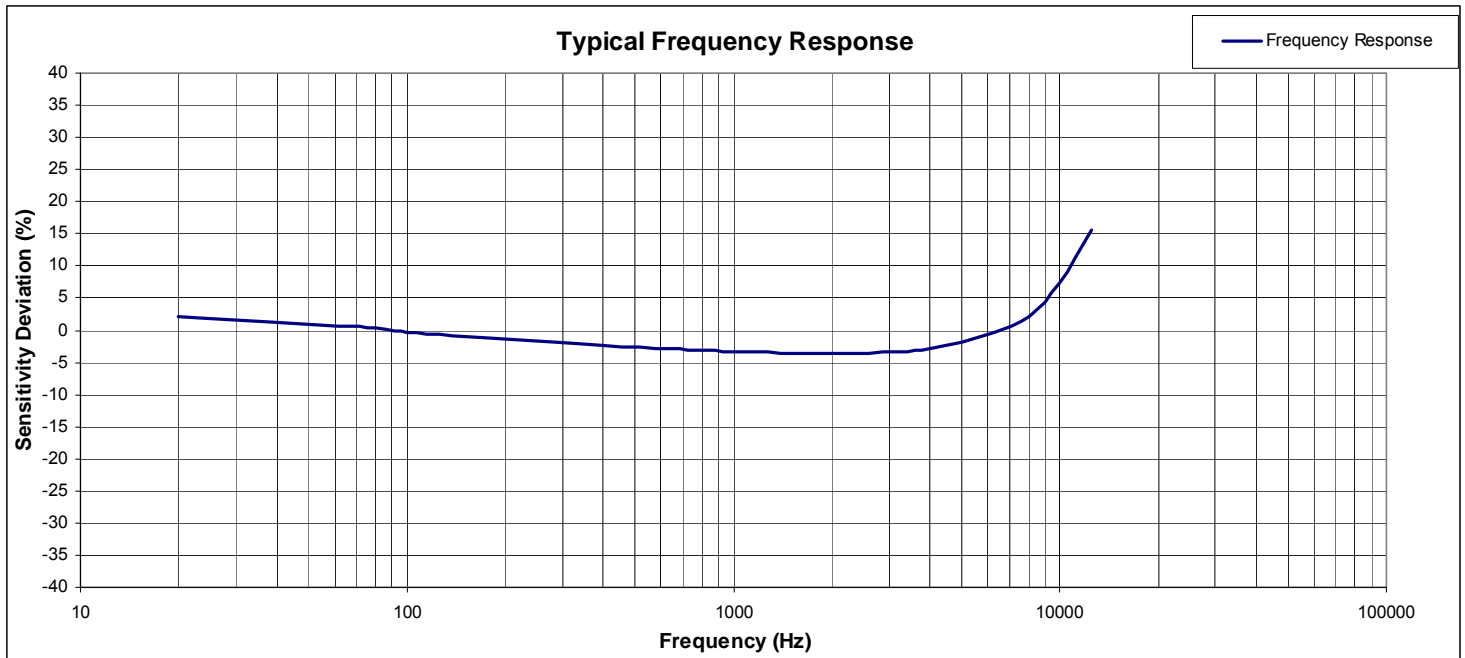

## 联系方式



深圳市亿为测控电子有限公司  
Shenzhen Bill-Well Measurement & Control Electronics Co., Ltd.

广东省深圳市南山区创业路怡海广场东座2407 邮编：518000

电话：+86 755 2641 9890 传真：+86 755 2641 9680

电子邮箱：sales@bill-well.com

[www.bill-well.com](http://www.bill-well.com)

深圳市亿为测控电子有限公司