

Model 7505A Accelerometer



+260°C Charge Output Accelerometer
5.6pC/g output, 10kHz Bandwidth
Hermetically Sealed
Stud Mount, Top Connector



The **Model 7505A** is a stud mounted piezoelectric charge mode accelerometer with an operating temperature range to +260°C. The accelerometer is designed for high frequency vibration and shock measurements and offers a wide bandwidth to >10kHz and a nominal charge output of 5.6pC/g. The model 7505A features a hermetically sealed stainless steel housing and a #10-32 stud mount configuration.

dimensions

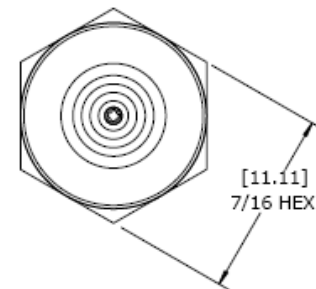

FEATURES

- -73°C to +260°C Operating Range
- Wide bandwidth up to >10kHz
- Stainless Steel Housing
- Annular Shear Mode
- Case Grounded
- 10-32 Top Connector

APPLICATIONS

- Vibration & Shock Monitoring
- High Temp Applications
- Laboratory Testing
- High Frequency Applications
- Gearbox Vibration Monitoring

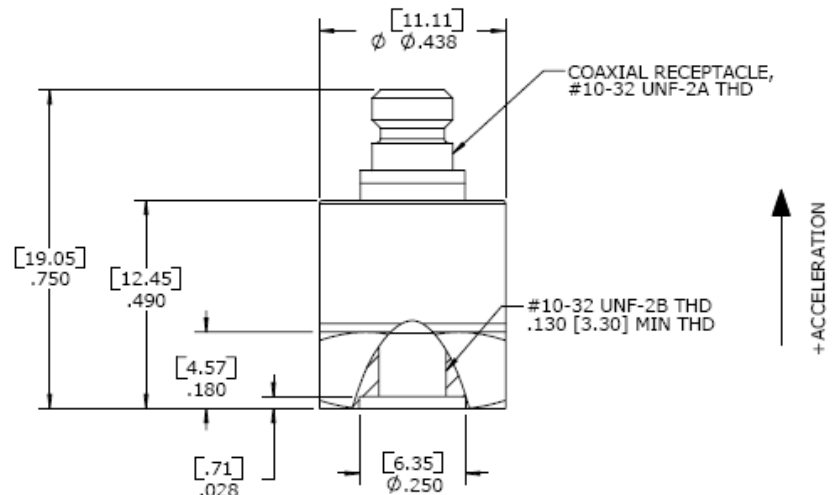

ACCELEROMETER

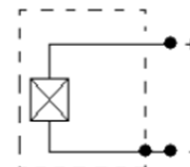

Model 7505A Accelerometer

performance specifications

All values are typical at +24°C, 100Hz unless otherwise stated. Measurement Specialties reserves the right to update and change these specifications without notice. Standard product parameters are described in PSC-1003 for Plug & Play AC Accelerometers.

Parameters

DYNAMIC

		Notes
Sensitivity (pC/g)	5.6	Typical
Sensitivity (pC/g)	4.0	Minimum
Frequency Response (Hz) ²	1-10000	±10%
Frequency Response (Hz) ²	0.3-15000	±2dB
Natural Frequency (Hz)	47000	
Non-Linearity (%FSO)	±1/1000g	
Transverse Sensitivity (%)	<5	
Dynamic Range (g) ¹	±4000	
Shock Limit (g)	10000	

ELECTRICAL

Capacitance (pF)	560	Nominal
Insulation Resistance (MΩ)	>100	@100Vdc
Grounding	Case Grounded	

ENVIRONMENTAL

Temperature Response (%)	See Typical Temperature Response Curve
Operating Temperature (°C)	-73 to +260
Storage Temperature (°C)	-73 to +260
Humidity	Hermetically Sealed

PHYSICAL

Sensing Element	Ceramic (shear mode)
Case Material	Stainless Steel
Weight (grams)	7.3
Mounting	#10-32 to #10-32 Mounting Stud (included)
Mounting Torque	18 lb-in (2.0 N-m)

¹ Operating range over which the accelerometer meets the linearity specifications

² Low-end response of the accelerometer is a function of its associated electronics.

Calibration supplied: CS-FREQ-0100 NIST Traceable Amplitude Calibration from 20Hz to ±2dB Frequency Response Limit

Supplied accessories: AC-D02298 10-32 to 10-32 mounting stud

Optional accessories: 320-XXX Cable Assembly, 10-32 to 10-32 (XXX designates length in inches, 10ft standard)
130 In-Line Charge Converter
161A 4-Channel PE & IEPE Signal Conditioner
AC-D03105 Adhesive Mounting Adaptor
AC-D03106 Magnetic Mounting Adaptor

Model 7505A Accelerometer

performance specifications

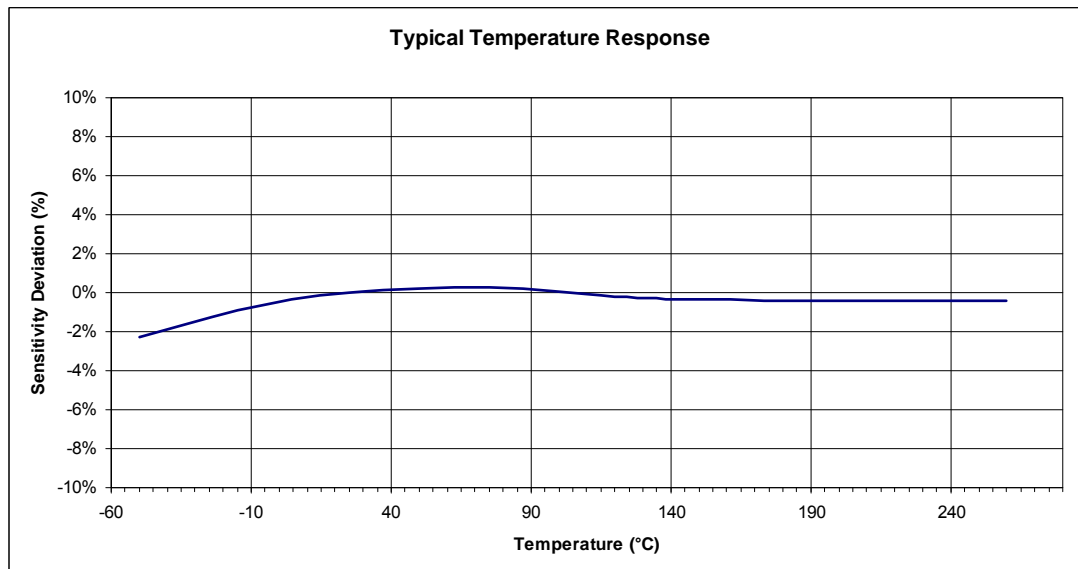
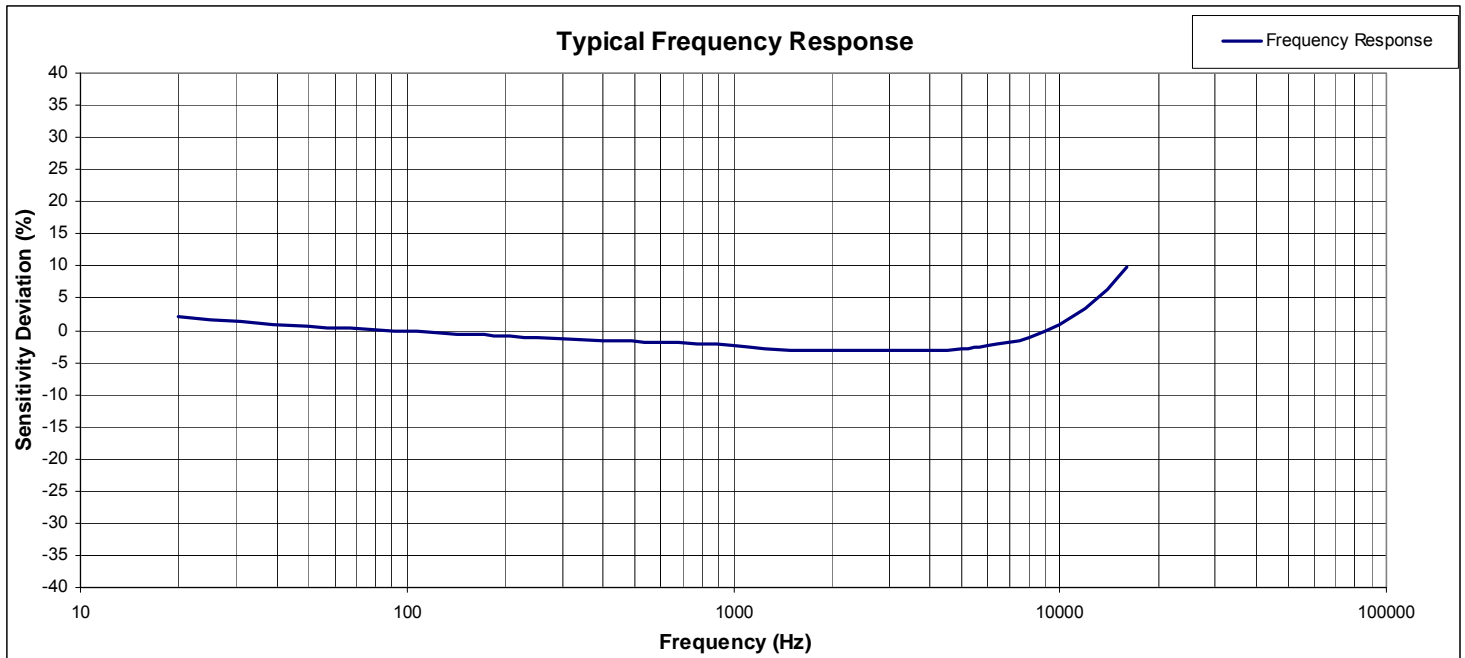

ordering info

PART NUMBERING Model Number

7505A

联系方式



深圳市亿为测控电子有限公司
Shenzhen Bill-Well Measurement & Control Electronics Co., Ltd.

广东省深圳市南山区创业路怡海广场东座2407 邮编：518000

电话：+86 755 2641 9890 传真：+86 755 2641 9680

电子邮箱：sales@bill-well.com

www.bill-well.com

深圳市亿为测控电子有限公司