

Model 606M1 Accelerometer



Seat Pad Accelerometer
MEMS, Triaxial Sensors
DC Response
Accurate Temp Compensation
ISO 10326-1 Configuration



The **Model 606M1** is a MEMS triaxial seat pad accelerometer with both static and dynamic responses designed specially for characterizing whole body vibration in accordance with ISO 2631-1 and ISO 8041. The DC response of the silicon MEMS sensors is the key to yield accurate velocity and displacement results from the raw acceleration data. The 606M1 incorporates integral temperature compensation that provides a stable output over a wide operating range. The on-board voltage regulation circuit works with power supply from 8 to 32Vdc.

dimensions

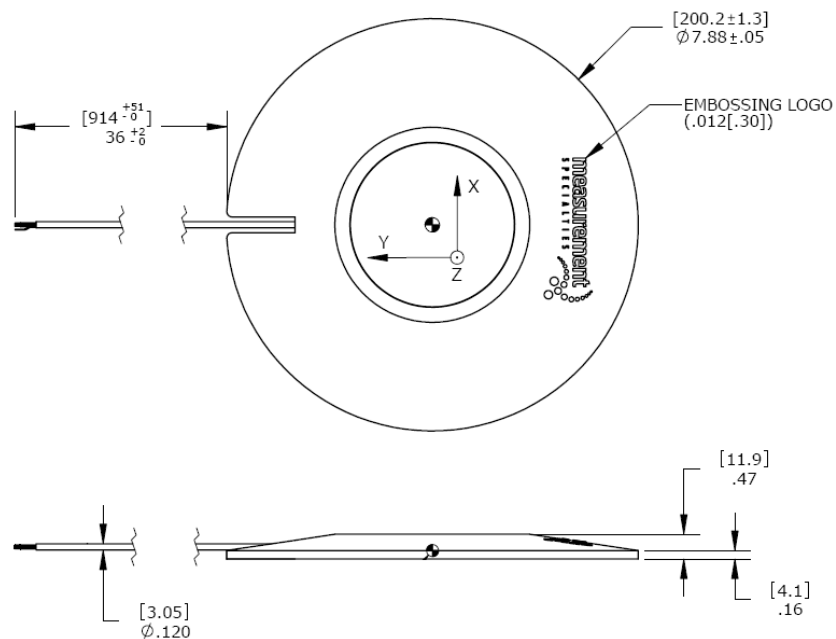

FEATURES

- Three Independent Circuits
- Low Current Consumption
- Ranges: $\pm 25g$
- Gas Damped, DC Response
- High Over-Range Protection
- Temperature Compensation
- Low Transverse Sensitivity

APPLICATIONS

- Whole Body Vibration Study
- Vibration/Shock Monitoring
- Helicopter Flight Testing
- Heavy Equipment Testing
- Biodynamic Study

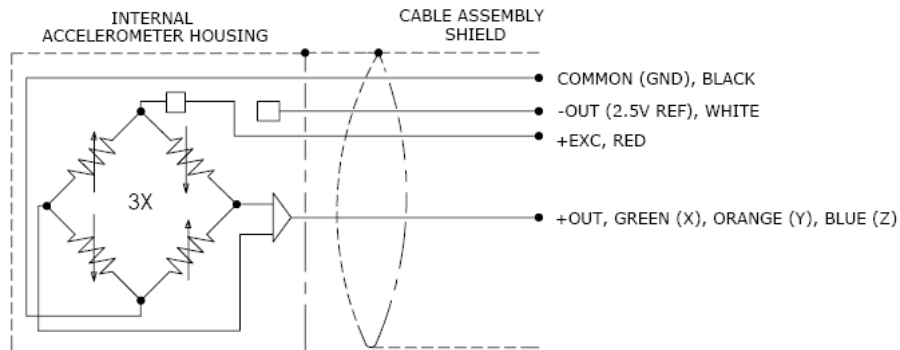

Model 606M1 Accelerometer

performance specifications

All values are typical at +24°C, 100Hz and 12Vdc excitation unless otherwise stated. Measurement Specialties reserves the right to update and change the specifications without notice. Standard product parameters are described in PSC-1004 for Plug & Play DC Accelerometers.

Parameters

DYNAMIC

		Notes
Range (g)	±25	
Sensitivity (mV/g)	80	
Frequency Response (Hz)	0-800	±5%
Frequency Response (Hz)	0-1000	±1dB
Natural Frequency (Hz)	4000	
Non-Linearity (%FSO)	±1.0	
Transverse Sensitivity (%)	<3	
Damping Ratio	0.7	
Shock Limit (g)	5000	

ELECTRICAL

Zero Acceleration Output (mV)	±100	Differential
Excitation Voltage (Vdc)	8 to 36	
Excitation Current (mA)	<15	
Bias Voltage (Vdc)	2.5	
Output Impedance (Ω)	<100	
Insulation Resistance (MΩ)	>100	@100Vdc
Turn On Time (msec)	<100	
Residual Noise (μV RMS)	800	Passband
Ground Isolation	Isolated from Mounting Surface	

ENVIRONMENTAL

Thermal Zero Shift (%FSO)	±3	Typical
Thermal Sensitivity Shift (%)	±3.5	Typical
Operating Temperature (°C)	-20 to 85	
Compensated Temperature (°C)	-20 to 85	
Storage Temperature (°C)	-20 to 85	

PHYSICAL

Case Material (Seat Pad)	Nitrile Rubber
Cable	6x #28 AWG Conductors, PFA Insulated, Braided Shield, TPE Jacket
Weight (grams)	380

Wiring color code:

X-axis: +Excitation = Red; +Output = Green; -Output (-2.5V Ref) = White; Common (Ground) = Black
Y-axis: +Excitation = Red; +Output = Orange; -Output (-2.5V Ref) = White; Common (Ground) = Black
Z-axis: +Excitation = Red; +Output = Blue; -Output (-2.5V Ref) = White; Common (Ground) = Black

Calibration supplied: CS-FREQ-0100 NIST Traceable Amplitude Calibration from 20Hz to ±5% Frequency Response Limit

Optional accessories: 101 Three Channel DC Signal Conditioner Amplifier

PART NUMBERING Model Number

606M1

联系方式



深圳市亿为测控电子有限公司
Shenzhen Bill-Well Measurement & Control Electronics Co., Ltd.

广东省深圳市南山区创业路怡海广场东座2407 邮编：518000

电话：+86 755 2641 9890 传真：+86 755 2641 9680

电子邮箱：sales@bill-well.com