

# Model EGCS-S425 Accelerometer



Range  $\pm 50$  to  $\pm 2000g$   
Critically Damped  
Internally Compensated  
ISO 6487 Compliant

The **Model EGCS-S425** is a small, ISO 6487 and SAE J211 compliant piezoresistive accelerometer. This unit features internal temperature compensation, anodized aluminum alloy housing and flexible cable output. This sensing element is damped with fluid to extend useful frequency range and reduce the effect of high frequencies.

## FEATURES

- Fluid Damping
- Ranges from  $\pm 50g$  to  $\pm 2000g$
- Flexible Cable
- $-20^{\circ}\text{C}$  to  $+80^{\circ}\text{C}$  Temperature Range
- Built-in mechanical stops
- Low zero offset  $< \pm 10$  mV
- Internal Temperature Compensation
- 10Vdc Excitation with  $\pm 150$  mV Output

## APPLICATIONS

- Auto Safety Testing
  - Crash
  - Sled
  - Dummy
- Pedestrian Impact



## dimensions

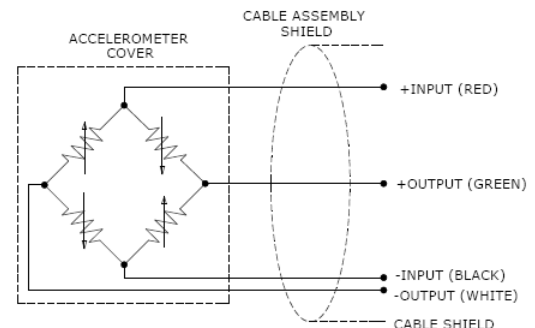
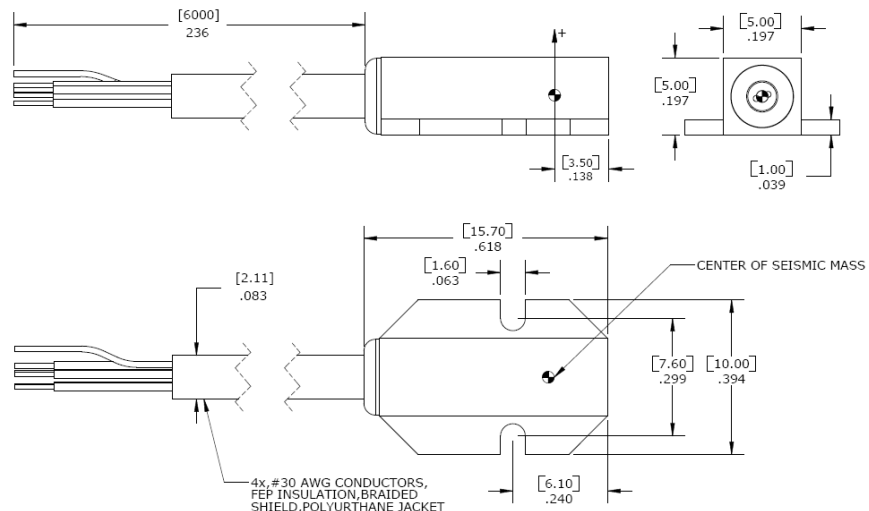

# Model EGCS-S425 Accelerometer

## performance specifications

All values are typical at  $\pm 24^{\circ}\text{C}$ , 100 Hz and 10Vdc excitation unless otherwise stated. Measurement Specialties reserves the right to update and change these specifications without notice. Standard product parameters are described in PSC-1004 for Plug & Play DC Accelerometers.

### RANGES AND OUTPUTS:

g range "FS"	g over-range limit	Attenuation Fh	Attenuation Fn	Attenuation 2Fh	Full Scale Output (mV / FSO)			Natural Frequency Min.
		At 180 Hz	At 300 Hz	At 360 Hz	Nom.	Min.	Max.	Min.
$\pm 50$	$\pm 5000$	$\pm 0.5\text{dB}$	+0.5dB / -2dB	+0.5dB / -4dB	$\pm 150$	$\pm 100$	$\pm 225$	1 kHz
$\pm 100$	$\pm 5000$	At 600 Hz	At 1000 Hz	At 1200 Hz	$\pm 150$	$\pm 100$	$\pm 225$	1.5 kHz
		$\pm 0.5\text{dB}$	+0.5dB / -2dB	+0.5dB / -4dB				
$\pm 250$	$\pm 10000$	$\pm 0.5\text{dB}$	+0.5dB / -2dB	+0.5dB / -4dB	$\pm 150$	$\pm 100$	$\pm 225$	2.5 kHz
$\pm 500$	$\pm 10000$	$\pm 0.5\text{dB}$	+0.5dB / -2dB	+0.5dB / -4dB	$\pm 150$	$\pm 100$	$\pm 225$	4.5 kHz
$\pm 1000$	$\pm 10000$	$\pm 0.5\text{dB}$	+0.5dB / -1dB	+0.5dB / -2dB	$\pm 150$	$\pm 100$	$\pm 225$	6 kHz
$\pm 2000$	$\pm 10000$	$\pm 0.5\text{dB}$	+0.5dB / -0.5dB	+0.5dB / -1dB	$\pm 150$	$\pm 100$	$\pm 225$	10 kHz

Parameter	Value	Unit	Notes
<b>DYNAMIC</b>			
Full Scale Output	$\pm 150$	mV	
Non-Linearity and Hysteresis	$< \pm 1$	%FSO	
Transverse Sensitivity	1	%	Nominal
Zero Acceleration Output	$\pm 10$	mV	
Thermal Zero Shift (TZS)	$\pm 3$	mV	
Thermal Sensitivity Shift (TSS)	$< \pm 0.1$	% / $^{\circ}\text{C}$	
Damping Ratio	0.7		Nominal
<b>ELECTRICAL</b>			
Voltage Excitation	10	Vdc	Alternate excitations available
Input Resistance	2000	$\Omega$	Nominal
Output Resistance	1000	$\Omega$	Nominal
<b>PHYSICAL</b>			
Weight Without Cable	$< 5$	Grams	Standard cable length = 6 meters
Case Material			Anodized aluminum
Cable	4x #30 AWG, FEP Insulated, Braided Shield, TPU Jacket		
<b>ENVIRONMENTAL</b>			
Operating Temperature	-20 to +80	$^{\circ}\text{C}$	
Compensated Temperature Range	-10 to +50	$^{\circ}\text{C}$	
Humidity			Epoxy sealed, IP61

# Model EGCS-S425 Accelerometer

## performance specifications

### OPTIONS AND ACCESSORIES

<b>Calibration supplied:</b>	CS-FREQ-0100	NIST Traceable Amplitude Calibration
<b>Optional accessories:</b>	AC-A04208	Triaxial Mounting Block
	101	Three Channel DC Signal Conditioner Amplifier
	140	Auto-zero Inline Amplifier

## ordering info

### EGCS – S425 – 100 – /Z1/L2M/C

|            | Options, otherwise leave blank  
|            | Range (100 is 100g)

### Excitation Voltage:

### Special Cable Length:

### Connector Wired to Cable:

### Dallas ID Module:

### Shunt Calibration:

Standard = 10Vdc

V\* = Non standard, contact factory

L00M = Replace "00" with length in meter

Contact Factory

Contact Factory

RCAL00 = Replace "00" with value of % Range  
(ex. RCAL50; 50% FS)

Example: EGCS-S425-2000-/L2M

Model EGCS-S425, 2000g Range, 2 Meter Cable Length

## 联系方式



深圳市亿为测控电子有限公司  
Shenzhen Bill-Well Measurement & Control Electronics Co., Ltd.

广东省深圳市南山区创业路怡海广场东座2407 邮编：518000

电话：+86 755 2641 9890      传真：+86 755 2641 9680

电子邮箱：sales@bill-well.com