

Model 3801A Accelerometer



Gas Damped, DC Response
Hermetically Sealed
mV Output
10,000g Over-Range Protection

The **Model 3801A** is a mV output piezoresistive MEMS accelerometer in a rugged welded hermetic package. The accelerometer incorporates mechanical stops for over-range protection up to greater than 10,000g. The model 3801A is offered in ranges from ± 2 to $\pm 2000g$ and is gas damped to provide a wide frequency response. The accelerometer is temperature compensated to provide a stable output over the operating environment.



dimensions

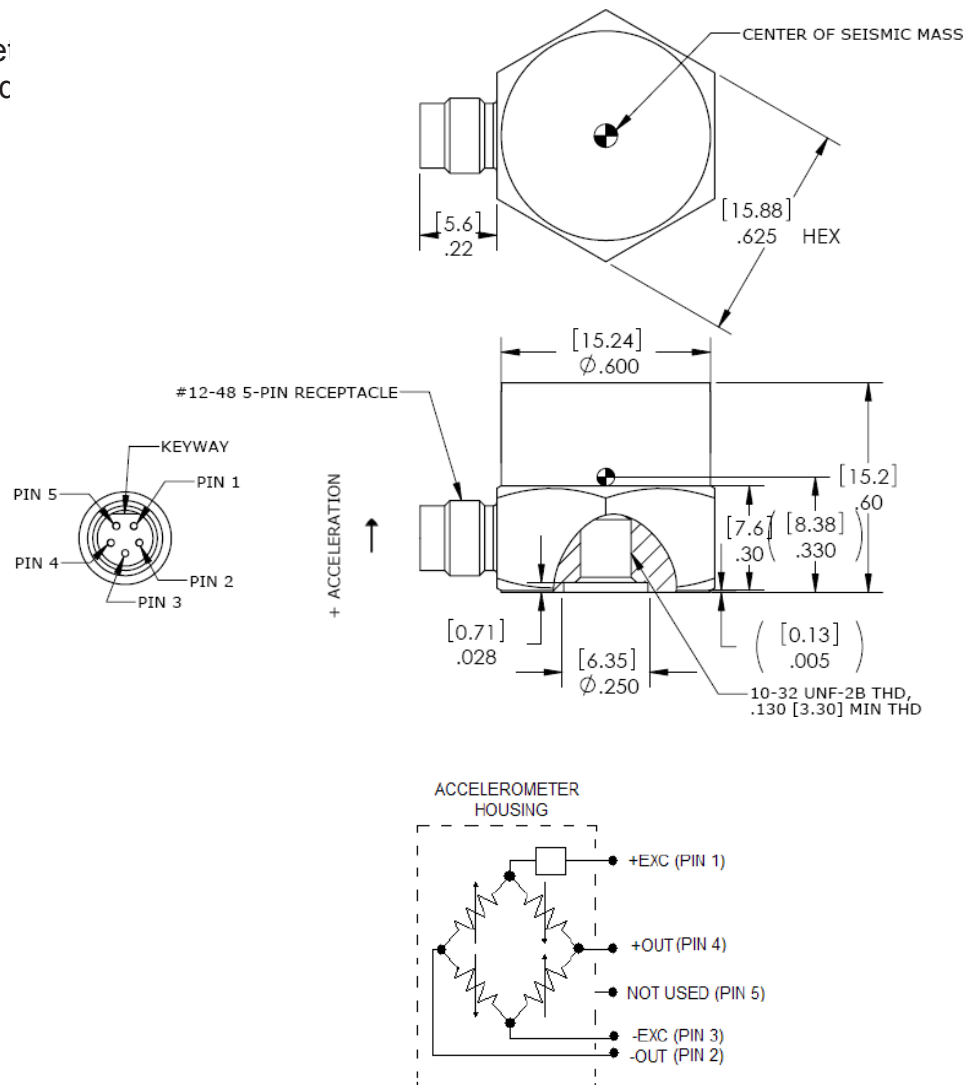

FEATURES

- $\pm 2g$ to $\pm 2000g$ Dynamic Range
- 10,000g Shock Protection
- Hermetically Sealed
- Gas Damping
- mV Output
- DC Response
- Stud Mounting

APPLICATIONS

- Impact Testing
- Structural Testing
- Test and Instrumentation
- Environmental Testing
- Vehicle Testing

Model 3801A Accelerometer

performance specifications

All values are typical at +24°C, 100Hz and 10Vdc excitation unless otherwise stated. Measurement Specialties reserves the right to update and change these specifications without notice. Standard product parameters are described in PSC-1004 for Plug & Play DC Accelerometers.

Parameters

DYNAMIC

	±2	±10	±20	±50	±100	±200	±500	±2000	Notes
Range (g)	±2	±10	±20	±50	±100	±200	±500	±2000	
Sensitivity (mV/g)	12	6	3	1.5	0.7	0.7	0.3	0.1	@10Vdc Excitation
Frequency Response (Hz)	0-100	0-300	0-400	0-800	0-1300	0-1500	0-2500	0-4000	±5% ¹
Frequency Response (Hz)	0-200	0-400	0-500	0-1000	0-1500	0-1800	0-3000	0-5000	±1dB
Natural Frequency (Hz)	700	1000	1500	4000	6000	7000	8000	10000	
Non-Linearity (%FSO)	±1.0	±1.0	±1.0	±1.0	±1.0	±1.0	±1.0	±1.0	
Transverse Sensitivity (%)	<3	<3	<3	<3	<3	<3	<3	<3	
Damping Ratio	0.7	0.7	0.7	0.7	0.7	0.6	0.5	0.3	
Shock Limit (g)	10000	10000	10000	10000	10000	10000	10000	10000	

ELECTRICAL

Zero Acceleration Output (mV)	±25	±25	±25	±25	±25	±25	±25	±25	Differential
Excitation Voltage (Vdc)	5 to 10	5 to 10	5 to 10	5 to 10	5 to 10	5 to 10	5 to 10	5 to 10	
Input Resistance (kΩ)	4 to 10	4 to 10	4 to 10	4 to 10	4 to 10	4 to 10	4 to 10	4 to 10	
Output Resistance (kΩ)	2.4 to 4.8	2.4 to 4.8	2.4 to 4.8	2.4 to 4.8	2.4 to 4.8	2.4 to 4.8	2.4 to 4.8	2.4 to 4.8	
Insulation Resistance (MΩ)	>100	>100	>100	>100	>100	>100	>100	>100	@100Vdc
Residual Noise (μV RMS)	10	10	10	10	10	10	10	10	Maximum
Ground Isolation	Isolated from Mounting Surface								

ENVIRONMENTAL

Thermal Zero Shift (%FSO/°C)	±0.04	±0.04	±0.04	±0.04	±0.04	±0.04	±0.04	±0.04	
Thermal Sensitivity Shift (%/°C)	±0.05	±0.05	±0.05	±0.05	±0.05	±0.05	±0.05	±0.05	
Operating Temperature (°C)	-55 to +125								
Compensated Temperature (°C)	-20 to +85								
Storage Temperature (°C)	-55 to +125								

PHYSICAL

Case Material	Stainless Steel
Weight (grams)	20
Mounting	#10-32 to #10-32 Mounting Stud (included)
Mounting Torque	18 lb-in (2.0 N-m)

Wiring color code: +Excitation = Pin 1; -Excitation = Pin 3; +Output = Pin 4; -Output = Pin 2
(Pin 5 is not used)

Calibration supplied: CS-FREQ-0100 NIST Traceable Amplitude Calibration from 20Hz to ±5% Frequency Response Limit¹

Supplied accessories: AC-D02298 10-32 to 10-32 mounting stud

Optional accessories: 340A-XXX Cable Assembly, #28 AWG, -54 to +121°C (XXX designates length in inches, 5ft standard)
343-XXX Cable Assembly, #28 AWG, -40 to +85°C (XXX designates length in inches, 5ft standard)
101 Three Channel DC Signal Conditioner Amplifier

ordering info

PART NUMBERING Model Number+Range

3801A-GGGG

|
| _____ Range (0100 is 100 g)

Example: 3801A-0100
Model 3801A, 100g

联系方式



深圳市亿为测控电子有限公司
Shenzhen Bill-Well Measurement & Control Electronics Co., Ltd.

广东省深圳市南山区创业路怡海广场东座2407 邮编: 518000

电话: +86 755 2641 9890 传真: +86 755 2641 9680

电子邮箱: sales@bill-well.com

www.bill-well.com

深圳市亿为测控电子有限公司