

# Model 3255A Accelerometer



PC Board Mountable Accelerometer  
Amplified Output  
Temperature Compensated  
High Over-Range Protection



The **Model 3255A** is a signal conditioned board mountable MEMS accelerometer available in  $\pm 25g$  to  $\pm 500g$  ranges. The package can be mounted in one of two orientations, allowing the measurement axis to be either parallel or perpendicular to the mounting surface without the use of costly brackets. The accelerometer incorporates integral temperature compensation and offers a flat frequency response from DC to 1500Hz.

## dimensions

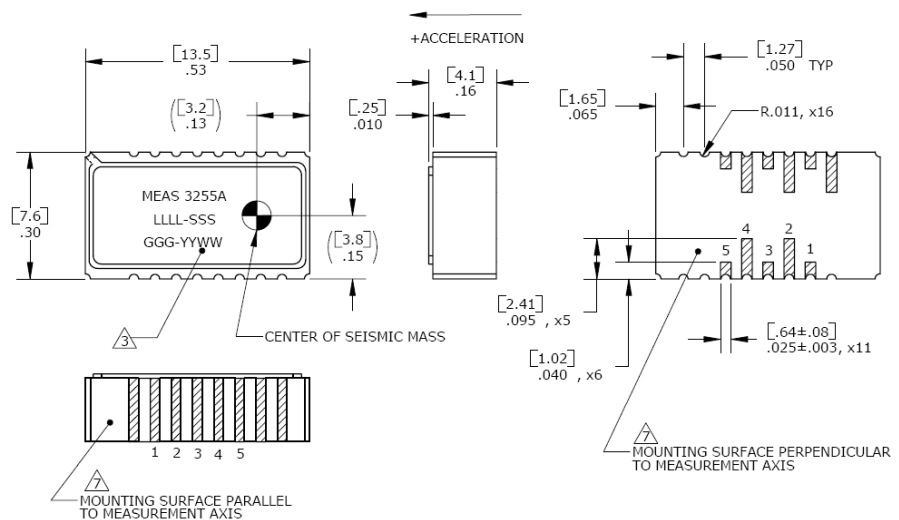

## FEATURES

- $\pm 25g$  to  $\pm 500g$  Ranges
- Three Axis Mounting Options
- Surface Mount Package
- DC Response, Gas Damping
- Hermetically Sealed
- 5Vdc Excitation

## APPLICATIONS

- Impact & Shock Testing
- Vibration & Shock Monitoring
- Embedded Applications
- Transportation Measurements

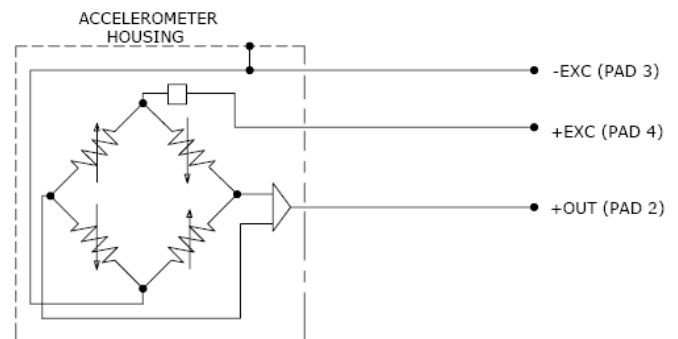

**US Patents 5,103,667; 5,253,510; 5,445,006; 5,503,016; and 5,616,863 apply**

# Model 3255A Accelerometer

## performance specifications

All values are typical at +24°C, 100Hz and 5Vdc excitation unless otherwise stated. Measurement Specialties reserves the right to update and change these specifications without notice. Standard product parameters are described in PSC-1002 for Embedded DC Accelerometers.

### Parameters

#### DYNAMIC

	±25	±50	±100	±250	±500	Notes
Range (g)	±25	±50	±100	±250	±500	
Sensitivity (mV/g) ±10%	80.0	40.0	20.0	8.0	4.0	@5Vdc Excitation <sup>1</sup>
Frequency Response (Hz)	0-800	0-1000	0-1200	0-1500	0-1500	±5%
Natural Frequency (Hz)	4000	4000	6000	8000	10000	
Non-Linearity (%FSO)	±0.5	±0.5	±0.5	±0.5	±0.5	
Transverse Sensitivity (%)	<3	<3	<3	<3	<3	<1 Typical
Damping Ratio	0.7	0.7	0.7	0.6	0.5	Typical
Shock Limit (g)	5000	5000	5000	5000	5000	

#### ELECTRICAL

Zero Acceleration Output (V)	2.5±0.10	2.5±0.10	2.5±0.10	2.5±0.10	2.5±0.10	Single-Ended
Excitation Voltage (Vdc) <sup>1</sup>	2.7 to 5.5	2.7 to 5.5	2.7 to 5.5	2.7 to 5.5	2.7 to 5.5	
Excitation Current (mA)	<5	<5	<5	<5	<5	
Bias Voltage (Vdc)	2.5	2.5	2.5	2.5	2.5	
Full Scale Output Voltage (Vdc)	±2.0	±2.0	±2.0	±2.0	±2.0	
Output Impedance (Ω)	<100	<100	<100	<100	<100	
Insulation Resistance (MΩ)	>100	>100	>100	>100	>100	@100Vdc
Residual Noise (μV RMS)	800	400	400	400	400	Passband
Ground Isolation	Isolated from Mounting Surface					

#### ENVIRONMENTAL

Thermal Zero Shift (%FSO/°C)	±0.018	±0.018	±0.018	±0.018	±0.018	
Thermal Sensitivity Shift (%/°C)	±0.021	±0.021	±0.021	±0.021	±0.021	
Operating Temperature (°C)	-54 to +121					
Compensated Temperature (°C)	-20 to +85					
Storage Temperature (°C)	-54 to +121					

#### PHYSICAL

Case Material	Ceramic
Weight (grams)	1.5
Mounting	Solder

<sup>1</sup>Output is ratiometric with excitation voltage.

<sup>2</sup>Do not electrically connect undesignated pads in sensor application. Except pad 5 may be tied to pad 4 without affecting performance.

<sup>3</sup>Maximum ratings without damage:

- Excitation voltage: +5.5Vdc
- ESD protection: 4kV
- Solder reflow temperature: +260°C (10 seconds)

<sup>4</sup>Adhesive underfill suggested for high-g applications.

**Calibration supplied:** CS-SENS-0100 NIST Traceable Amplitude Calibration at 100Hz

## ordering info

PART NUMBERING Model Number+Range

3255A-GGG

|  
| \_\_\_\_\_ Range (050 is 50 g)

Example: 3255A-050  
Model 3255A, 50g

## 联系方式



深圳市亿为测控电子有限公司  
Shenzhen Bill-Well Measurement & Control Electronics Co., Ltd.

广东省深圳市南山区创业路怡海广场东座2407 邮编：518000

电话：+86 755 2641 9890 传真：+86 755 2641 9680

电子邮箱：sales@bill-well.com

电话：+86 755 2641 9890

www.bill-well.com

深圳市亿为测控电子有限公司