

R120LC – DC Operated Low Cost RVIT



- Low cost
- 5VDC supply voltage
- 0 to 120 degree sensing range
- Non-contact design
- ¼ inch shaft diameter
- Ratiometric output
- No wear potentiometer replacement
- Light weight

DESCRIPTION

The **R120LC** RVIT (Rotary Variable Inductance Transducer) is a cost efficient, DC operated non-contact angular position sensor. It provides a smooth 0.5 to 4.5VDC output, ratiometric to the supply voltage and proportional to angular position over the 120 degree sensing range. The R120LC utilizes non-contacting, differential inductive technology, and does not suffer the wear problems experienced by potentiometers.

The R120LC proprietary design utilizes a set of four printed circuit coils and a light-weight conductive spoiler to achieve superior performance with a low moment of inertia. During operation, the light weight spoiler rotates with the transducer shaft, differentially altering the inductance of the printed circuit planar coils. The resulting unbalance is precisely measured using a patented autoplex circuit. This signal is then converted to a linear DC output voltage proportional to the angle of the rotor shaft. The digital circuit provides resistance to environmental disturbances such as EMI and RFI, and is ideally suited to the most rigorous industrial applications.

Calibrated over the full 120 degree sensing range, the R120LC offers exceptional performance at a cost effective price. It also features a wide operating temperature range, infinite resolution, and an extremely long rotational cycle life.

Also see our other DC operated, angular position sensor models, **RVIT-15 Series** (single ended DC operation, voltage or current output), **R60D** (bipolar DC operation), and the **R30D** (DC operated RVDT).

*MEAS acquired Schaevitz Sensors and the **Schaevitz**® trademark in 2000.*

FEATURES

- Precision ball bearings
- Infinite resolution
- Low moment of inertia
- Long term reliability
- Wide operating temperature range

APPLICATIONS

- Valve position
- Fly-by-wire joy-stick position feedback
- General aviation stall warning sensor
- Potentiometer replacement

R120LC – DC Operated Low Cost RVIT

PERFORMANCE SPECIFICATIONS

ELECTRICAL SPECIFICATIONS	
Input voltage	5±0.25 VDC
Input current	21mA maximum
Angular range	0 to 120 degree
Non-linearity	±0.5% of FSO
Output at range ends	+0.5 to +4.5 VDC (ratiometric to input voltage)
Sensitivity	6.67mV/V/degree (ratiometric to input voltage)
Temp coefficient of output	±0.02% of FSO per °F [0.03% of FSO per °C], over operating temperature range
Output current	5mA maximum
Output impedance	1Ω maximum
Non-repeatability and hysteresis	0.1% of FRO maximum
Frequency response	200 HZ @ -3 dB

ENVIRONMENTAL AND MECHANICAL SPECIFICATIONS	
Operating temperature range	-13°F to +185°F [-25°C to 85°C]
Storage temperature range	-67°F to +257°F [-55°C to 125°C]
Mechanical angular range	360 degrees (no stops)
Bearings	ABEC 3 precision
Shaft diameter	¼ inch [6.3mm]
Torque	0.12 inch.ounce-force [8.6 gram-force.cm]
Weight	1.2oz [34gm]
Electrical connection	4 lead wires, 28 AWG , PTFE insulation, 12 inches [30cm] long

Notes:

All values are nominal unless otherwise noted

FSO (Full Scale Output): Largest absolute value of the outputs measured at the ends of the range

FRO (Full Range Output): Algebraic difference in outputs measured at the ends of the range

DIMENSIONS

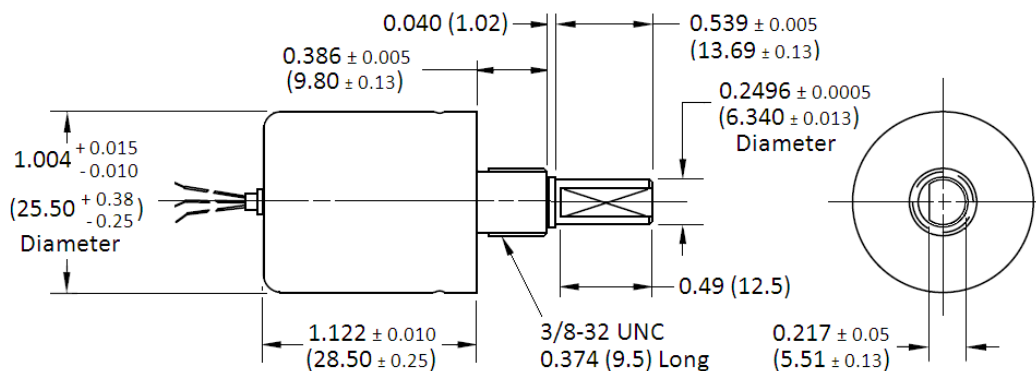

Dimensions are in inch (mm)

R120LC – DC Operated Low Cost RVIT

WIRING INFORMATION

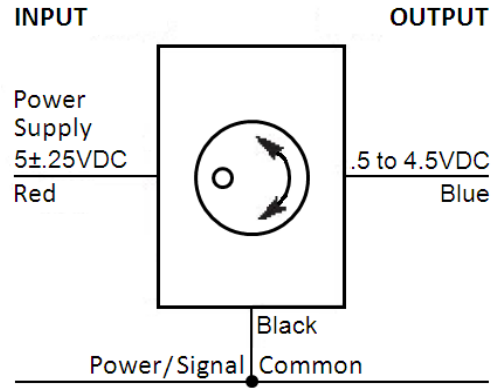

ORDERING INFORMATION

Description	Model	Part Number
RVIT 0-120°	R120LC	02183000-000

联系方式



深圳市亿为测控电子有限公司
Shenzhen Bill-Well Measurement & Control Electronics Co., Ltd.

广东省深圳市南山区创业路怡海广场东座2407 邮编：518000
电话：+86 755 2641 9890 传真：+86 755 2641 9680
电子邮箱：sales@bill-well.com