

ATA-2001 – Analog LVDT/RVDT Signal Conditioner with digital calibration



- 115 or 220 VAC line powered
- Microprocessor controlled calibration
- Superior digital filtering
- Selectable excitation frequencies & amplitudes
- Voltage and current outputs
- 250 to 1000Hz selectable frequency response
- Auto fall-back synchronization
- Splash-proof front panel with status LEDs
- 1/8 DIN standard panel mounting

DESCRIPTION

The **ATA-2001** is a general purpose, AC line-powered, LVDT/RVDT analog conditioner with digital setup and calibration. The embedded microprocessor generates a PWM-shaped sine wave and handles all calibration functions. It also controls the demodulation, filtration and synchronization of the LVDT or RVDT transducer signal. All settings are stored in non-volatile memory for restoration on power up. Zero, Gain and Phase adjustments are accomplished via the use of splash-proof front panel pushbuttons and digital voltage dividers. Intended for the most demanding industrial applications, the ATA 2001 is CE certified, and has been rigorously tested to the highest industrial standards for EMI, RFI and ESD.

Designed for universal compatibility with 4, 5 and 6 electrical connection transducers, the ATA-2001 provides a wide range of oscillator frequencies, gains and two excitation voltages, affording maximum interface versatility. The very high drive current of 45mA allows operation with transducer input impedances as low as 12 Ohms (with 0.5 VRMS excitation). With high gain capability and low noise, the ATA 2001 provides measurement resolutions beyond any product currently available.

The **unique auto fall-back synchronization** feature allows reliable master/slave operation, for prevention of amplifier cross talk, without the worry of sync signal loss. If the internal processor in a slave amplifier detects an unstable or missing sync signal, the internal clock will take over, continuing at the pre-selected nominal frequency. Upon restoration of a normal sync pulse, the oscillator will return to the slave mode.

The ATA 2001 is contained within a rugged, one-piece, extruded aluminum housing which provides optimal amplifier performance under the most rigorous EMI and RFI conditions. An integral panel mounting system provides for convenient 1/8 DIN standard, panel installation. A pre-punched 19" rack adapter is also available to accommodate up to eight amplifiers per adapter installation.

Also see our other signal conditioner models, **LDM-1000** (DIN rail mount, VDC and 4-20mA output), **LVM-110** (VDC input/output), **LiM-420** (4-20mA transmitter), **PML-1000** (1/8th DIN panel meter, VDC, current and RS485 outputs), and our **IEM-422** (NEMA-13 rated 4-20mA transmitter).

MEAS acquired Schaevitz Sensors and the **Schaevitz**[®] trademark in 2000.

FEATURES

- Microprocessor controlled & non-volatile memory
- Phase shift compensation
- Auto fall-back synchronization
- Rugged extruded aluminum housing

APPLICATIONS

- Power-gen turbine control
- Head box slice lip position control
- Roller gap position feedback
- Precision metrology labs

ATA-2001 – Analog LVDT/RVDT Signal Conditioner with digital calibration

PERFORMANCE SPECIFICATIONS

ELECTRICAL SPECIFICATIONS	
Line power requirements	115VAC $\pm 10\%$, 50-400Hz; 220VAC $\pm 10\%$, 50-400Hz (<i>switch selectable</i>)
Line voltage regulation	$\pm 10\%$, with no change in output
Voltage output	
Unipolar voltage output range	0 to 10VDC, with 10mA maximum current capability
Bipolar voltage output range	± 10 VDC (using 100% zero suppression), with 10mA maximum current capability
Noise and ripple (voltage output)	3mV RMS maximum @ 2.5KHz excitation frequency
Output impedance (voltage output)	1 Ω maximum
Current output	
Current output range	4 to 20mA
Maximum loop resistance	700 Ω with internal loop supply; 1000 Ω with 24VDC external supply (<i>32vdc MAX</i>)
Noise and ripple (current output)	10 μ A rms (max)
Analog outputs frequency response	
Frequency response @ -3db	250Hz @ 2.5kHz excitation 500Hz @ 5.0kHz excitation 1000Hz @ 10kHz excitation
Amplifier characteristics	
Transducer input sensitivity range	High gain: 0.04 to 0.9 VRMS; Low gain: 0.5 to 10 VRMS (<i>switch selectable</i>)
Input impedance	100k Ω
Zero suppression range	$\pm 110\%$ of FSO
Phase shift compensation range	± 120 degrees maximum
Non-linearity and hysteresis	$\pm 0.05\%$ of FSO, maximum
Stability	$\pm 0.05\%$ of FSO, maximum, after 20 minute warm up
Temperature coefficient of output	$\pm 0.02\%$ of FSO per degree F [$\pm 0.036\%$ per degree C] over operating temp. range
Transducer excitation	
Voltage	0.5 or 3.5 VRMS, sine wave (<i>switch selectable</i>)
Current	45mA RMS maximum
Frequency	2.5, 5 or 10kHz (<i>switch selectable</i>)
Transducer requirements	
Transducer type	LVDT or RVDT with 4, 5 or 6 electrical connections
Input impedance (Primary)	12 Ω minimum with 0.5 VRMS excitation; 80 Ω minimum with 3.5 VRMS excitation
Full scale output	High gain: 0.04 to 0.9 VRMS; Low gain: 0.5 to 10 VRMS

ENVIRONMENTAL AND MECHANICAL SPECIFICATIONS	
Operating temperature range	-40°F to +185°F [-40°C to 85°C]
Storage temperature range	-40°F to +257°F [-40°C to 125°C]
Weight	2.1lbs [950 grams]
Transducer electrical connections	DB-9S (See our transducer data sheets for jumper cables or connector option)
Output and sync connections	Barrier terminal strip
Mounting	1/8 DIN standard panel mounting (<i>19" rack adapter for 8-up available</i>)

Notes:

All values are nominal unless otherwise noted

FSO (Full Scale Output) is the largest absolute value of the outputs measured at the range ends

ATA-2001 – Analog LVDT/RVDT Signal Conditioner with digital calibration

WIRING – INPUT (TRANSDUCER)

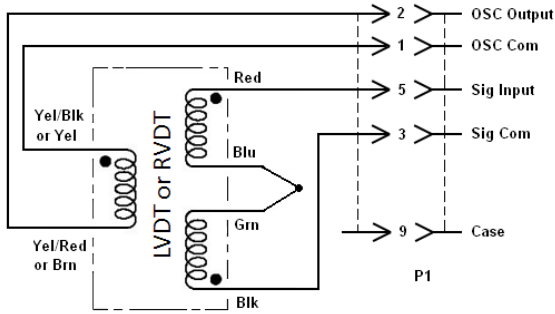

TRANSDUCER WITH LEADS OR CABLE

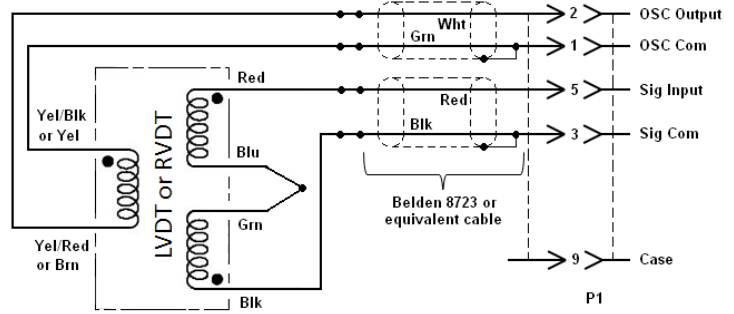

TRANSDUCER WITH LEAS AND SPLICED CABLE

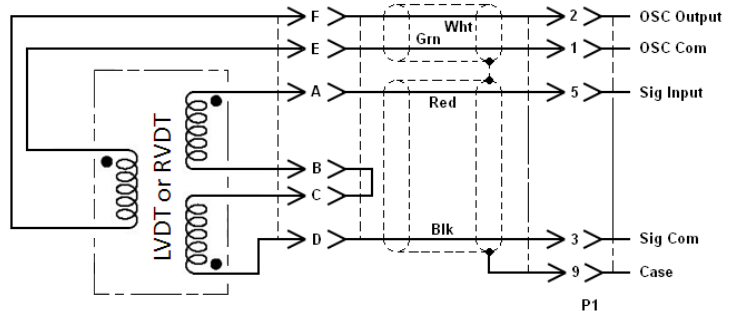
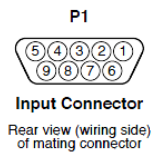

TRANSDUCER WITH CONNECTOR AND JUMPER CABLE

WIRING – OUTPUT

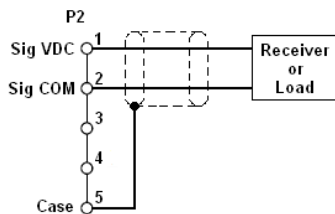

VOLTAGE OUTPUT

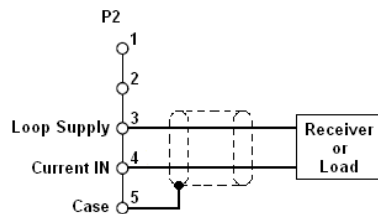

4-20mA OUTPUT USING THE INTERNAL LOOP SUPPLY

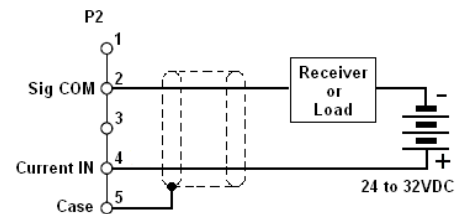

4-20mA OUTPUT USING AN EXTERNAL LOOP SUPPLY

ATA-2001 – Analog LVDT/RVDT Signal Conditioner with digital calibration

DIMENSIONS

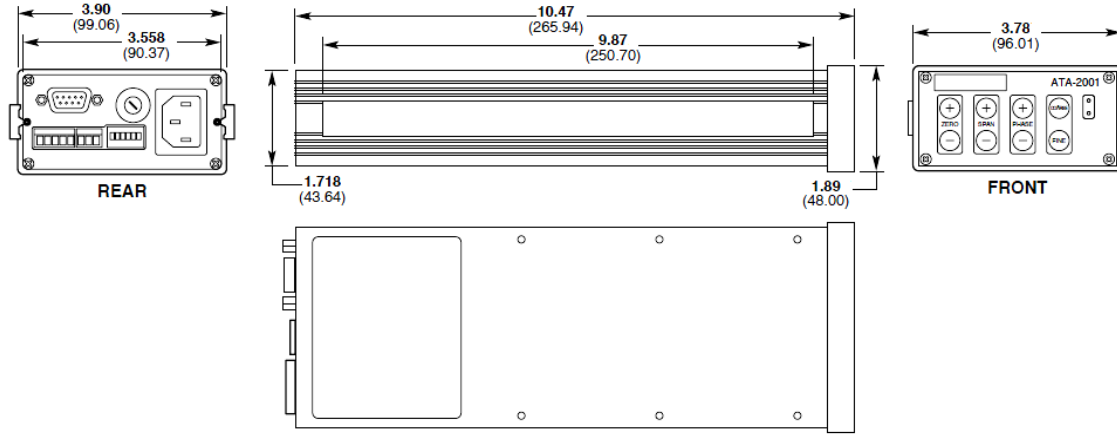

DIMENSIONS - RACK ADAPTOR (SOLD SEPARATELY)

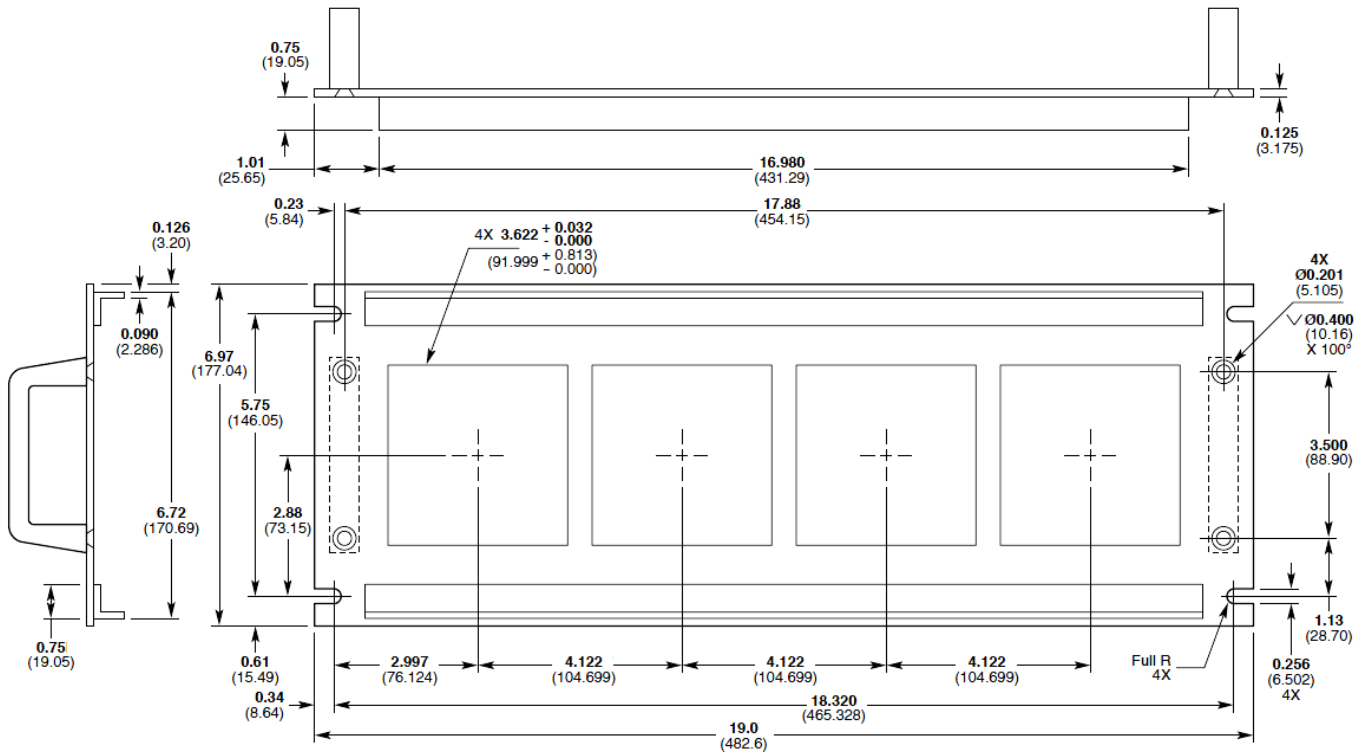

Accommodates up to eight ATA-2001 Amplifiers
 Dimensions are in inch (mm)

ATA-2001 – Analog LVDT/RVDT Signal Conditioner with digital calibration

ORDERING INFORMATION

Description	Part Number
ATA-2001 LVDT/RVDT Signal Conditioner	02291327-000
Rack Adaptor for up to 8 signal conditioners <i>(ATA-2001 conditioners not included)</i>	05290032-000
Cable to connect HCA/HCI Series LVDTs, GCA Series Gage Heads, and R36AS RVDT to ATA-2001 (1) <i>(PTO6A-10-6S to DB-9P connector)</i>	04290457-000
Extension cable to connect LBB Series (option -004) Gage Heads to ATA-2001 (1) <i>(DB-9S to DB-9P connector)</i>	04290565-000
Extension Cable to connect LBB (option -001) to ATA-2001 (1) <i>(PTO6A-10-6S to DB-9P connector)</i>	04290577-000

(1) All cables are shielded, 10 foot long, and are rated 80°C [176°F] operating. Consult factory for other lengths.

联系方式



深圳市亿为测控电子有限公司
Shenzhen Bill-Well Measurement & Control Electronics Co., Ltd.

广东省深圳市南山区创业路怡海广场东座2407 邮编：518000

电话：+86 755 2641 9890 传真：+86 755 2641 9680

电子邮箱：sales@bill-well.com