

# M-12 Series - Layer wound AC LVDT



- Premium performance at competitive price
- Low 100ppm/°C temperature coefficient
- Low phase shift
- Metric 12mm housing diameter
- Stroke ranges from  $\pm 10$  to  $\pm 100$ mm
- Stainless steel housing
- Magnetically shielded
- Imperial or metric threaded core

## DESCRIPTION

The **M-12 Series** of layer-wound LVDTs offer premium performance at standard LVDT pricing. The M-12 series are wound with state-of-the art, computerized winding machines on a ribless bobbin, resulting in the smooth transfer function required for the most demanding materials testing and position feedback applications. Precision distribution and tapering of the layer windings provide an excellent stroke to length ratio, without sacrificing sensor linearity.

A constant sum of the secondary output voltages throughout the linear range insures compatibility with ratiometric signal conditioning schemes for even lower temperature coefficients (refer to MEAS application note "Principles of the LVDT" in our online [resource library](#)).

The M-12 Series coil designs have been optimized to provide the lowest possible temperature coefficient of sensitivity, while maintaining suitability for operation with extended cable lengths. An internal high-permeability magnetic shield provides protection in the noisiest electromagnetic environments, while the high-quality AISI 304 Series stainless steel housing protects the LVDT from corrosion in aggressive environments.

Like in most of our LVDTs, the M-12 windings are vacuum impregnated with a specially formulated, high temperature, flexible resin, and the coil assembly is potted inside its housing with a two-component epoxy. This provides excellent protection against hostile environments such as high humidity, vibration and shock.

Measurement Specialties, Inc. (NASDAQ MEAS) offers many other types of sensors and signal conditioners. Data sheets can be downloaded from our web site at: <http://www.meas-spec.com/datasheets.aspx>

MEAS acquired Schaevitz Sensors and the **Schaevitz™** trademark in 2000.

## FEATURES

- Small 12mm diameter case
- Low temperature coefficient of sensitivity
- Excellent stroke to length ratio
- Smooth transfer function
- Constant sum of secondary output voltages
- Electromagnetic shielding
- AISI 304 Series stainless steel case

## APPLICATIONS

- Materials testing extensometers
- Cylinder position feedback
- Hydraulic spool valve position feedback
- Roller gap positioning
- Automotive suspension testing
- Flight simulators
- Aircraft flight control feedback

# M-12 Series - Layer wound AC LVDT

## PERFORMANCE SPECIFICATIONS

ELECTRICAL SPECIFICATIONS						
Parameter	M-12 10	M-12 20	M-12 30	M-12 50	M-12 65	M-12 100
Stroke range	±0.39 [±10]	±0.79 [±20]	±1.18 [±30]	±1.97 [±50]	±2.56 [±65]	±3.94 [±100]
Sensitivity, V/V/inch [mV/V/mm]	1.07 [42.0]	0.54 [21.2]	0.25 [10.0]	0.25 [9.9]	0.22 [8.8]	0.18 [7.1]
Output at stroke ends (*)	420mV/V	424mV/V	300mV/V	495mV/V	573mV/V	710mV/V
Phase shift	+3°	+2°	+2°	+3°	-2°	-3°
Input impedance (PRIMARY)	570Ω	1100Ω	1540Ω	780Ω	1500Ω	1000Ω
Output impedance (SECONDARY)	540Ω	400Ω	600Ω	825Ω	920Ω	1700Ω
Non-linearity	±0.25% of FR, maximum					
Input voltage	3 VRMS sine wave					
Test frequency	2.5kHz					
Null voltage	0.5% of FRO, maximum					

ENVIRONMENTAL SPECIFICATIONS & MATERIALS	
Operating temperature	-65°F to +300°F [-55°C to 150°C]
Temperature coefficient of sensitivity	0.018% per degree F [0.01% per degree C]
Shock survival	500 g (11ms half-sine)
Vibration tolerance	20 g up to 2KHz
Housing material	AISI 304 Series stainless steel
Electrical connection	Six lead-wires, 26 AWG, PTFE insulated, 1 foot [0.3m] long

**Notes:**

*Dimensions are in inch [mm]*

*All values are nominal unless otherwise noted*

*Electrical specifications are for the test frequency indicated in the table*

*FR: Full Range is the stroke range, end to end; FR=2xS for ±S stroke range*

*FRO (Full Range Output): Algebraic difference in outputs measured at the ends of the range*

*(\*): Unit for output at stroke ends is millivolt per volt of excitation*

# M-12 Series - Layer wound AC LVDT

## MECHANICAL SPECIFICATIONS

Parameter	M-12 10	M-12 20	M-12 30	M-12 50	M-12 65	M-12 100
Main body length "A"	2.64 [67]	3.82 [97]	4.61 [117]	6.10 [155]	7.87 [200]	11.22 [285]
Core length "B"	1.42 [36]	1.81 [46]	1.81 [46]	1.81 [46]	2.36 [60]	2.95 [75]
Bore diameter "D"	0.122 [3.1]	0.122 [3.1]	0.122 [3.1]	0.122 [3.1]	0.134 [3.4]	0.134 [3.4]

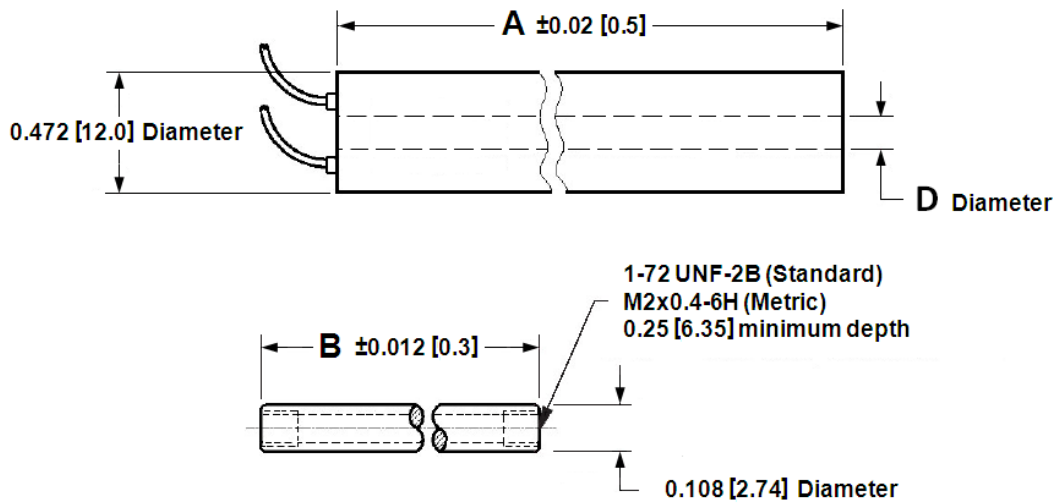

Dimensions are in inch [mm]

## WIRING INFORMATION

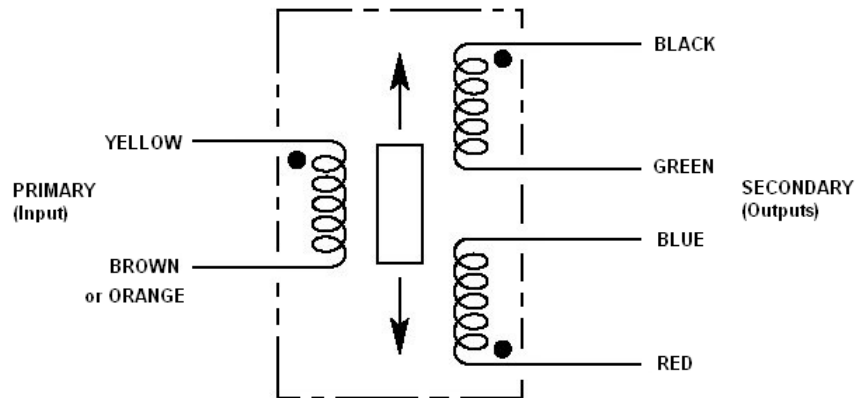

Connect Green to Blue for differential output

# M-12 Series - Layer wound AC LVDT

## ORDERING INFORMATION

Description	Model	Part Number
±10mm LVDT	M-12 10	02561036-000
±20mm LVDT	M-12 20	02561037-000
±30mm LVDT	M-12 30	02561038-000
±50mm LVDT	M-12 50	02561039-000
±65mm LVDT	M-12 65	02561043-000
±100mm LVDT	M-12 100	02561040-000
OPTIONS		
5.0 KHz calibration		XXXXXXXX-002
Metric threaded core option (M2x0.4-6H threads)		XXXXXXXX-006
5.0 KHz calibration AND metric threaded core option		XXXXXXXX-008

ACCESSORIES	
Core connecting rod, 6 inches long, 1-72 threads	05282945-006
Core connecting rod, 12 inches long, 1-72 threads	05282945-012
Core connecting rod, 24 inches long, 1-72 threads	05282945-024
Core connecting rod, 36 inches long, 1-72 threads	05282945-036
Core connecting rod, 6 inches long, M2x0.4 metric threads	05282976-006
Core connecting rod, 12 inches long, M2x0.4 metric threads	05282976-012
Mounting block	04560956-000

Refer to our "[Accessories for LVDTs](#)" data sheet for our LVDT signal conditioning instrumentation and other accessories.

## 联系方式



深圳市亿为测控电子有限公司  
Shenzhen Bill-Well Measurement & Control Electronics Co., Ltd.

广东省深圳市南山区创业路怡海广场东座2407 邮编：518000

电话：+86 755 2641 9890 传真：+86 755 2641 9680

电子邮箱：sales@bill-well.com