

# XS-ZTR Series – Extreme environment LVDT



- Cryogenic/high-temperature operation
- Gamma and neutron radiation resistant
- 2500 PSI [172 bar] operating pressure
- 100% inorganic material construction
- Stroke ranges of  $\pm 0.1$  and  $\pm 0.25$  inch
- Hermetically sealed
- Stainless steel housing
- Imperial or metric threaded core

## DESCRIPTION

The **XS-ZTR Series** of LVDTs were specifically designed for measuring displacements in extremely high and very low, cryogenic temperature environments. The XS-ZTR will operate continuously from **-320 to +1020°F** [-195 to +550°C], and will survive non-operating temperatures of up to +1200F [650°C]. It is also capable of performing within specification after radiation exposure to a total integrated neutron flux of  $3 \times 10^{20}$  NVT or  $3 \times 10^{24}$  n/m<sup>2</sup>, and gamma-ray total integrated dose radiation of  $10^{11}$  rad or  $10^9$  Gy.

The XS-ZTR is made exclusively from inorganic materials, specifically selected for their compatible expansion coefficients in order to minimize thermally induced stresses. The coil windings are of ceramic insulated precious metal alloys, while all seams and joints are either welded or brazed with high temperature alloys. The leads are sheathed in stainless steel, with conductors composed of nickel with magnesium oxide insulation. These cables can be terminated to a sealed header or connector if required.

As most inorganic insulation materials are hygroscopic, the entire coil assembly is hermetically sealed inside a stainless steel case. This prevents moisture accumulation, insulation leakage, and protects the coil from hostile surrounding media while allowing the core to move freely.

The XS-ZTR Series is compatible with all Measurement Specialties LVDT signal conditioners, controllers and readouts.

For moderate temperature and radiation applications, consider using our **HR** or **HCA** series LVDT with the MRR (mildly radiation resistant) option.

Measurement Specialties, Inc. (NASDAQ MEAS) offers many other types of sensors and signal conditioners. Data sheets can be downloaded from our web site at: <http://www.meas-spec.com/datasheets.aspx>

*MEAS acquired Schaevitz Sensors and the **Schaevitz**® trademark in 2000.*

## FEATURES

- Extreme operating temperature range
- Radiation resistant
- Single or dual cable configurations
- Optional sealed header or connector
- Special temperature calibrations available
- Calibration certificate supplied with each unit

## APPLICATIONS

- Material testing in pressurized autoclaves
- Nuclear reactor containment vessel bolt tension
- Nuclear reactor valve position
- Cryogenic medicine
- Jet engine thrust vectoring feedback
- Roll gap on steel hot strip and slabbing mills

# XS-ZTR Series – Extreme environment LVDT

---

## RADIATION RESISTANCE

---

Certain applications require resistance to a combination of gamma radiation, neutron radiation and high temperature. Before considering detailed specifications and suitability for a particular application, a review of the following working definitions and equivalents is appropriate.

### Total integrated neutron flux

The total integrated neutron flux (also called neutron fluence) is the neutron flux integrated over time.

Neutron flux: the total distance travelled by all neutrons per unit time and volume

Formula for neutron flux:  $\text{number of neutrons/volume} \times \text{distance/time} = \text{neutron density} \times \text{velocity}$

Neutron density: number of neutrons (n) per unit volume

Formula for total integrated neutron flux:

$\text{neutron density} \times \text{velocity} \times \text{time} = \text{neutron density} \times \text{distance}$

Unit for total integrated neutron flux:

$n/m^3 \times m = n/m^2$  (n: number of neutrons; m: meter)

or

**NVT** ( $n/cm^2$ )

Conversion:  $1 \text{ NVT} = 10^4 \text{ n/m}^2$

### Gamma-ray total integrated dose (TID) radiation

The absorbed dose of ionizing radiation is the amount of energy deposited per unit of mass.

Units: *rad (radiation absorbed dose): radiation that will deposit 0.01 Joule of energy per kilogram of matter*

*Gy (Gray): radiation that will deposit 1 joule of energy per kilogram (SI unit)*

Conversion:  $1 \text{ Gy} = 100 \text{ rad}$

All radiation produces some damage, therefore, the issue becomes how much radiation and what kind of radiation can an object sustain while maintaining its operation specification. At best, this can only be an estimate.

When radiant energy falls on an object, equal amounts of energy from different sources may result in greatly differing amounts of damage depending on the form of radiation, i.e. gamma rays, neutrons, etc. These different sources may also result in qualitatively different kinds of damage. One method to quantify these differences is to determine the rate of radiation that a unit can withstand without instantaneous and unacceptable damage. Another method is to determine the total integrated flux that can be absorbed before “wear-out” damage from radiation occurs. The distinction between rate of flux and total integrated flux must be kept clearly in mind.

There is no direct relationship between neutron fluence and gamma radiation. If we assume equal energy dissipation from differing sources, the energy absorbed by the unit will vary with its absorption cross section. If we try to equalize damage, there is even more uncertainty because of the qualitative differences of the damage caused by various forms of radiation.

# XS-ZTR Series – Extreme environment LVDT

## PERFORMANCE SPECIFICATIONS

ELECTRICAL SPECIFICATIONS		
Parameter	XS-ZTR 100	XS-ZTR 250
Stroke range	±0.10 [±2.54]	±0.25 [±6.35]
Sensitivity V/V/inch [mV/V/mm]	1.3 [51]	0.3 [12]
Output at stroke ends (*)	130mV/V	75mV/V
Phase shift	-8°	+20°
Input impedance (PRIMARY)	95Ω	100Ω
Output impedance (SECONDARY)	250Ω	80Ω
Non-linearity (Room temperature only)	±0.5% of FR maximum	
Input voltage	3 VRMS sine wave	
Test input frequency	2.5kHz	
Input frequency range	400Hz to 5kHz	
Null voltage	0.5% of FSO maximum	

ENVIRONMENTAL SPECIFICATIONS & MATERIALS	
Operating temperature	-320 to +1020°F [-195 to +550°C]
Non-operating temperature	-455 to +1200°F [-270 to +650°C]
Radiation resistance	
Total integrated neutron flux:	3 x 10 <sup>20</sup> NVT or 3 x 10 <sup>24</sup> n/m <sup>2</sup> maximum
Gamma-ray total integrated dose:	10 <sup>11</sup> rad or 10 <sup>9</sup> Gy maximum
Operating pressure	2,500 psi [172 bar] maximum
Shock survival	10 g (11ms half-sine)
Vibration tolerance	10 g up to 2KHz
Housing material	AISI 304 Series stainless steel
Electrical connection, standard	Cable with six lead-wires, 28 AWG solid nickel, MgO insulated, 72 inches [180 cm] long, and 3/16 inch [4.8mm] diameter stainless steel sheath; 1/2 inch [12.7mm] minimum bend radius
Electrical connection, optional (Consult factory)	Pair of 2-conductor, 1/16 inch [1.6 mm] diameter stainless steel sheathed cables. Particularly suitable for applications where the cables are routed through an arduous path within the reactor

**Notes:**

Dimensions are in inch [mm]

All values are nominal unless otherwise noted

Electrical specifications are for the test frequency indicated in the table

(\*): Unit for output at stroke ends is millivolt per volt of excitation (input voltage)

FR: Full Range is the stroke range, end to end; FR=2xS for ±S stroke range

FSO (Full Scale Output): Largest absolute value of the outputs measured at the ends of the range

# XS-ZTR Series – Extreme environment LVDT

## MECHANICAL SPECIFICATIONS

Parameter	100 XS-ZTR	250 XS-ZTR
Main body length "A"	2.51 [63.8]	3.83 [97.3]
Core length "B"	1.35 [34.3]	1.35 [34.3]
Body weight, oz [g]	2.3 [65]	4.1 [116]
Core weight, oz [g]	0.09 [2.5]	0.28 [7.9]

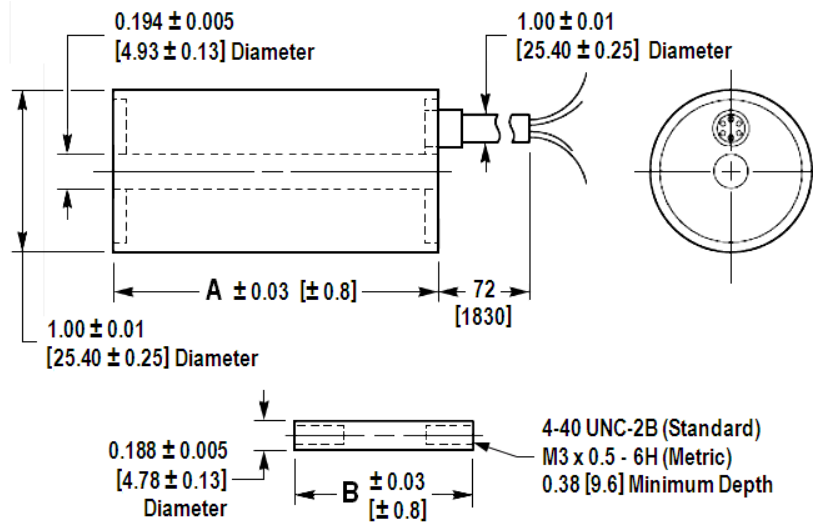

Dimensions are in inch [mm]

## WIRING INFORMATION

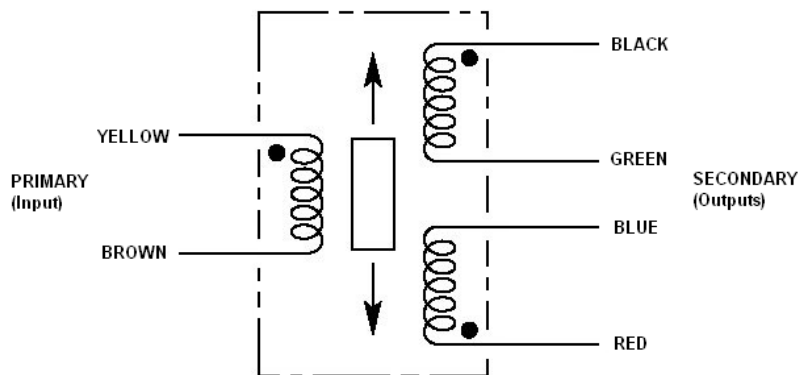

Connect Green to Blue for differential output

# XS-ZTR Series – Extreme environment LVDT

## ORDERING INFORMATION

Description	Model	Part Number
±0.10 inch LVDT	XS-ZTR 100	02560825-000
±0.25 inch LVDT	XS-ZTR 250	02560826-000

OPTIONS		
Metric threaded core option (M3x0.5-6H threads)	All	XXXXXXXX-006

ACCESSORIES	
Core connecting rod, 6 inches long, 6-40 threads	05282946-006
Core connecting rod, 12 inches long, 6-40 threads	05282946-012
Core connecting rod, 24 inches long, 6-40 threads	05282946-024
Core connecting rod, 36 inches long, 6-40 threads	05282946-036
Core connecting rod, 6 inches long, M3x0.5 metric threads	05282977-006
Core connecting rod, 12 inches long, M3x0.5 metric threads	05282977-012

Refer to our "[Accessories for LVDTs](#)" data sheet for our LVDT signal conditioning instrumentation and other accessories.

**IMPORTANT:** This product is made in the USA. Export is strictly regulated by the US Government.

## 联系方式



深圳市亿为测控电子有限公司  
Shenzhen Bill-Well Measurement & Control Electronics Co., Ltd.

广东省深圳市南山区创业路怡海广场东座2407 邮编：518000

电话：+86 755 2641 9890 传真：+86 755 2641 9680

电子邮箱：sales@bill-well.com