

# Magnetic Length Sensor MLS (Hybrid)

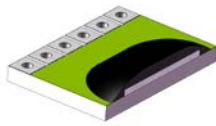

Small Hybride



Large Hybride

- AMR gradient sensor
- Linear displacement, movements, velocities
- High precision
- Various pole pitches available

## DESCRIPTION

Sliding the MLS-Sensors along a magnetic scale will produce a sine and a cosine output signal as a function of the position. In order to deliver satisfying results, this will be achieved as long as the air gap between sensor edge and magnetic scale does not exceed approximately half of the pole pitch. As the sensor principle is based on the anisotropic magneto resistance effect, the signal amplitudes are nearly independent on the magnetic field strength and therefore air gap variations do not have a strong effect on the accuracy. The sensor detects a magnetic gradient field and is thus almost insensitive to homogenous magnetic stray fields.

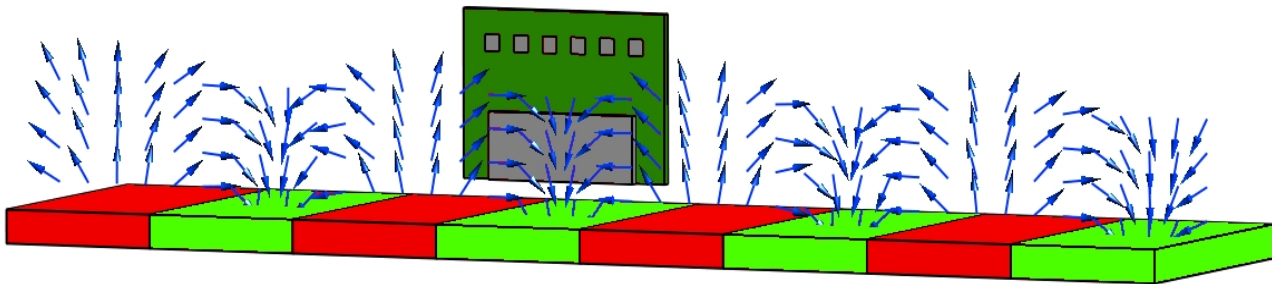

Precise displacement values will be obtained by using a sine/cosine decoder device. The maximal obtainable precision depends on the accuracy of the magnetic scale and on the distance sensor – magnetic scale. Values of <1% of the pole pitch are common.

## FEATURES

- Sin- / cos-output signals suitable for signal evaluation by standard-ASIC's
- Very high precision
- Insensitive to air gap fluctuations
- Highly reliable
- Low interference field sensitivity

## APPLICATIONS

- Linear displacement, movements, velocities in dirty environments
- Very precise angular measurement using pole wheels

# Magnetic Length Sensor MLS (Hybrid)

## SENSOR BASICS

The MLS-sensors consists of two magneto resistive Wheatstone bridges, whose resistors are placed in a way that in combination with a magnetic scale, a sine and a cosine signal is obtained. Thus, MLS sensors will only work together well with pole stripes that meet the design pole pitch. In addition, some sensor types integrate over more than one pole in order to improve sensor performance.

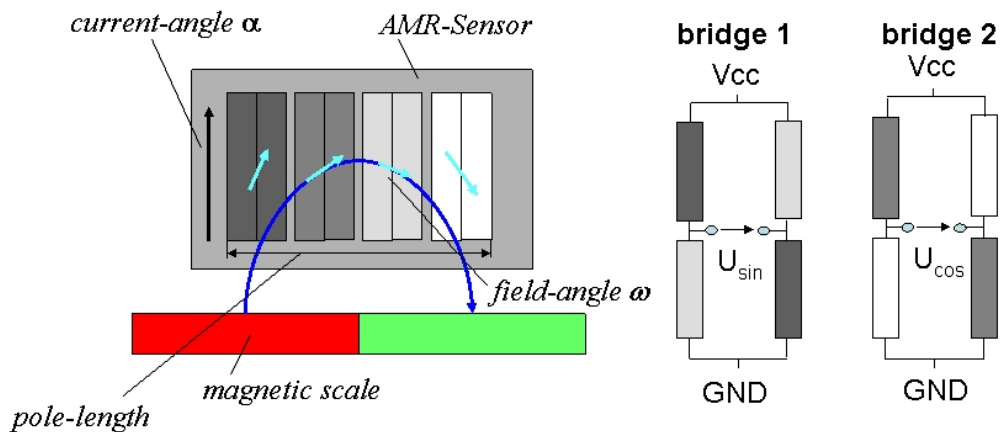

## CHARACTERISTIC VALUES

PARAMETER	SYMBOL	CONDITION	TYPE	MIN	TYP	MAX	UNIT
<b>1. Operating Limits</b>							
max. supply voltage	$V_{cc,max}$					<b>10</b>	V
max. current (both bridges)	$I_{cc,max}$		MLS1000/8 MLS2000/5000			<b>5</b> <b>10</b>	mA
operating temperature	$T_{op}$			<b>-40</b>		<b>+85</b>	°C
storage temperature	$T_{st}$			<b>-40</b>		<b>+125</b>	°C
<b>2. Sensor Specifications (T=25 °C)</b>							
Supply voltage	$V_{cc}$				<b>5</b>		V
pole pitch *)	$p$		MLS1000 MLS2000 MLS5000 MLS8		<b>1000</b> <b>2000</b> <b>5000</b> <b>2500</b>		$\mu\text{m}$
Resistance (both bridges)	$R_b$		MLS1000 MLS2000/5000 MLS8	<b>2000</b> <b>1000</b> <b>30000</b>	<b>3000</b> <b>1500</b> <b>40000</b>	<b>4000</b> <b>2000</b> <b>50000</b>	$\Omega$
Output signal range	$\Delta V_n/V_{cc}$	A, B		<b>16</b>	<b>22</b>		mV/V
Offset voltage	$V_{n,off}$	A, B		<b>-1</b>	<b>0</b>	<b>+1</b>	mV/V
<b>3. Sensor Specifications</b>							
TC of amplitude	TCSV	A, C			<b>-0.35</b>		%/K
TC of resistance	TCBR	A, C			<b>+0.32</b>		%/K
TC of offset	TCVoff	A, C		<b>-4</b>	<b>0</b>	<b>+4</b>	$\mu\text{V/V/K}$

$n = 1;2$  (bridge number); Stress above one or more of the limiting values may cause permanent damage to the device. Exposure to limiting values for extended periods may affect device reliability.

\*) other pole pitches on request

# Magnetic Length Sensor MLS (Hybrid)

## MEASUREMENT CONDITIONS

PARAMETER	SYMBOL	UNIT	CONDITION
<b>A. Set Up Conditions</b>			
ambient temperature	T	°C	T = 25 °C (unless otherwise noted)
supply voltage	V <sub>cc</sub>	V	V <sub>cc</sub> = 5 V
applied magnetic field	H	kA/m	H > 10 kA/m
<b>B. Sensor Specifications (T=25 °C, 360° turn , H=25 kA/m , V<sub>o</sub>max&gt;0, V<sub>o</sub>min&lt;0)</b>			
output signal range	$\Delta V_n / V_{cc}$	mV/V	$\Delta V_n / V_{cc} = (V_{n \max} - V_{n \min}) / V_{cc}$
signal offset	V <sub>off n</sub>	mV/V	$V_{off n} = (V_{n \max} + V_{n \min}) / V_{cc}$
<b>C. Sensor Specifications (T=-25°C, +125°C)</b>			
ambient temperatures	T	°C	T <sub>1</sub> = -25 °C, T <sub>0</sub> = +25 °C, T <sub>2</sub> = +125 °C
TC of amplitude	TCSV	%/K	$TCV = \frac{1}{(T_2 - T_1)} \cdot \frac{\frac{\Delta V_n}{V_{cc}}(T_2) - \frac{\Delta V_n}{V_{cc}}(T_1)}{\frac{\Delta V_n}{V_{cc}}(T_1)} \cdot 100\%$
TC of resistance	TCBR	%/K	$TCR = \frac{1}{(T_2 - T_1)} \cdot \frac{R_n(T_2) - R_n(T_1)}{R_n(T_1)} \cdot 100\%$
TC of offset	TCVoff	μV/(VK)	$TCV_{off_n} = \frac{V_{off_n}(T_2) - V_{off_n}(T_1)}{(T_2 - T_1)}$

n = 1;2 (bridge number)

# Magnetic Length Sensor MLS (Hybrid)

## PACKAGES

### HD (SMALL TWO SIDED HYBRID)

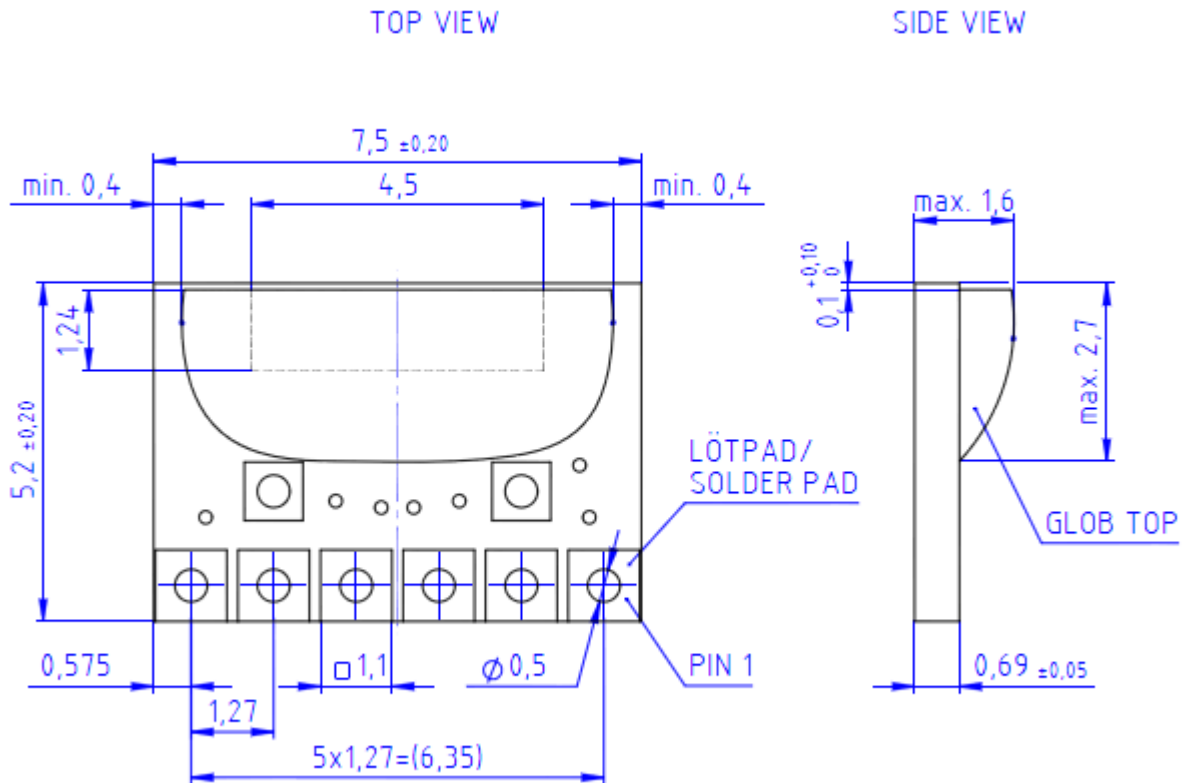

### BOTTOM VIEW

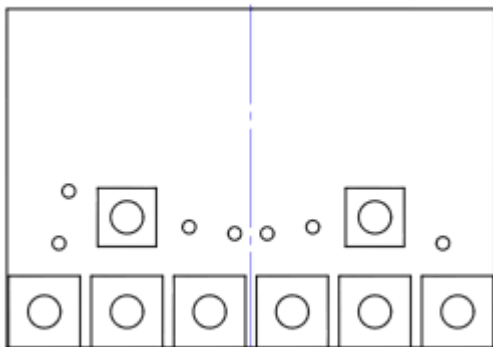

Pin	MLS1000HD	MLS2000HD	MLS5000HD	MLS8HD
1	GND	+V2	+V2	+V2
2	Vcc	Vcc	Vcc	Vcc
3	-V2	GND	GND	GND
4	+V2	+V1	+V1	+V1
5	-V1	-V1	-V1	-V2
6	+V1	-V2	-V2	-V1

# Magnetic Length Sensor MLS (Hybrid)

HK (SMALL HYBRID)

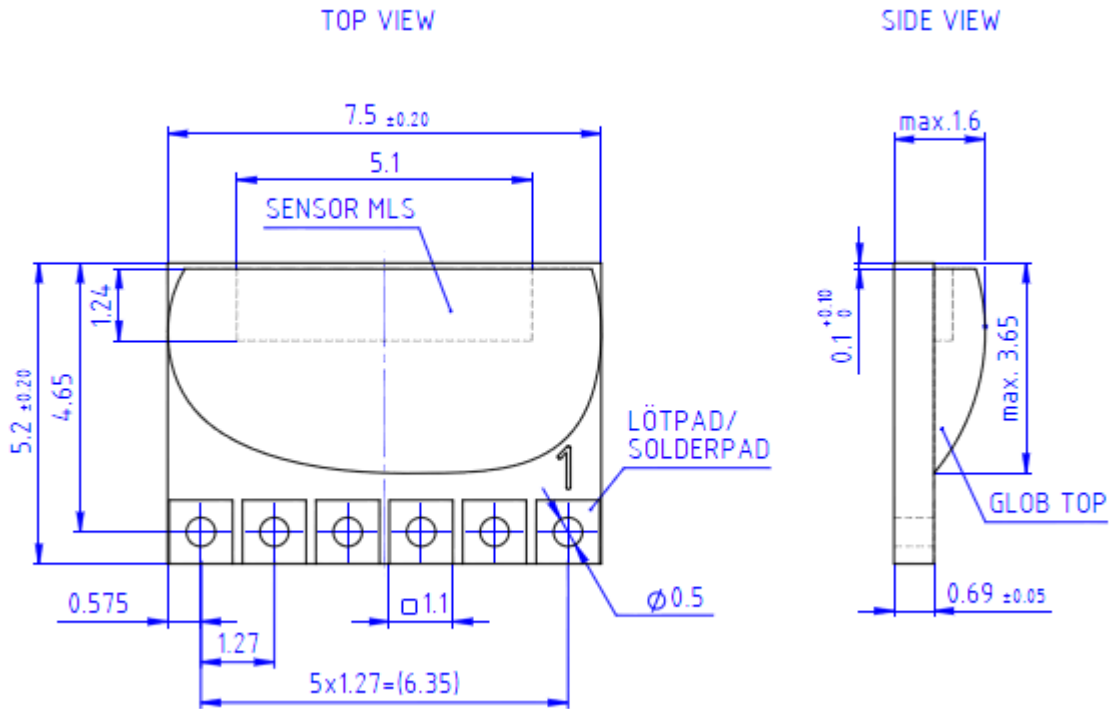

**BOTTOM VIEW**

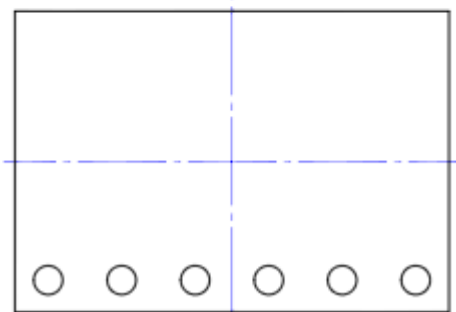

Pin	Annotation	Name
1	Output signal	V <sub>cos-</sub>
2	Supply voltage	V <sub>cc</sub>
3	Ground	GND
4	Output signal	V <sub>sin-</sub>
5	Output signal	V <sub>sin+</sub>
6	Output signal	V <sub>cos+</sub>

# Magnetic Length Sensor MLS (Hybrid)

HS (STANDARD HYBRID)

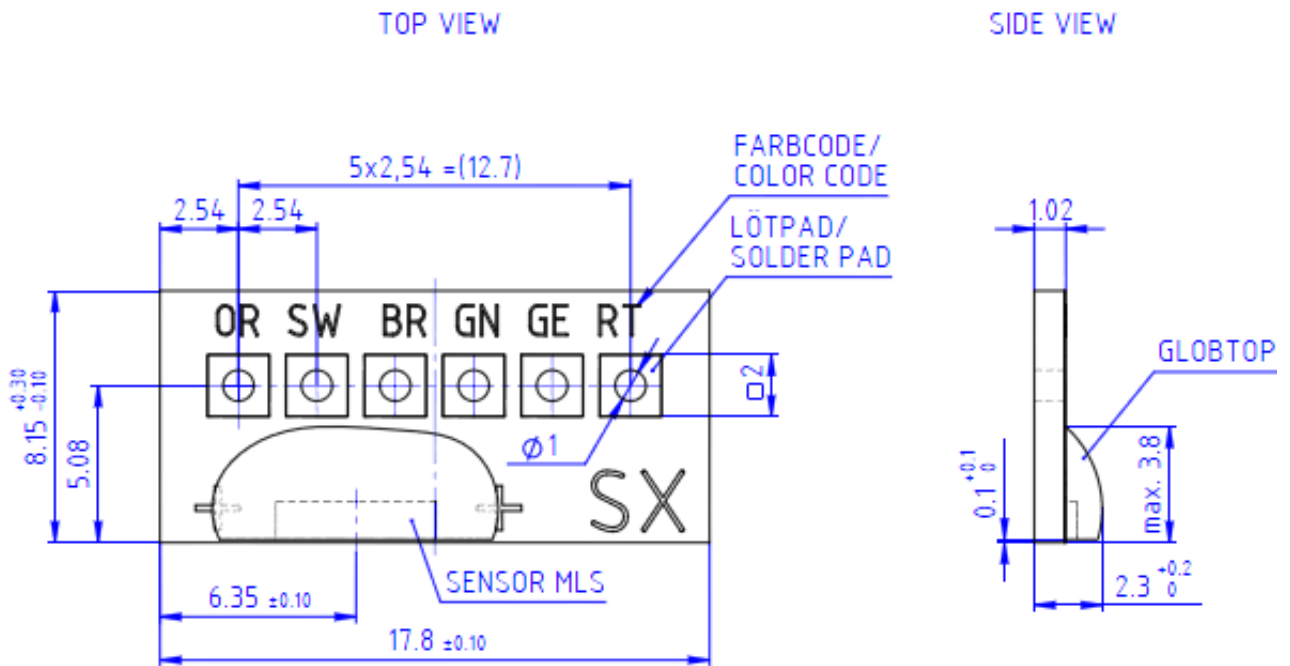

BOTTOM VIEW

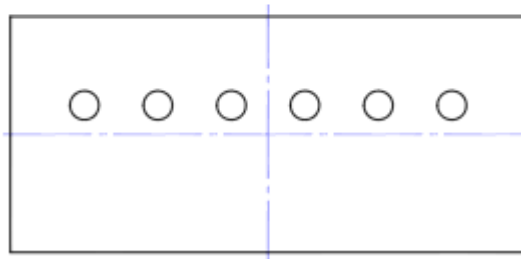

Pin	Annotation	Name
OR	Output signal	$V_{\cos-}$
SW	Supply voltage	$V_{cc}$
BR	Ground	GND
GN	Output signal	$V_{\sin-}$
GE	Output signal	$V_{\sin+}$
RT	Output signal	$V_{\cos+}$

# Magnetic Length Sensor MLS (Hybrid)

## EVALUATION KIT

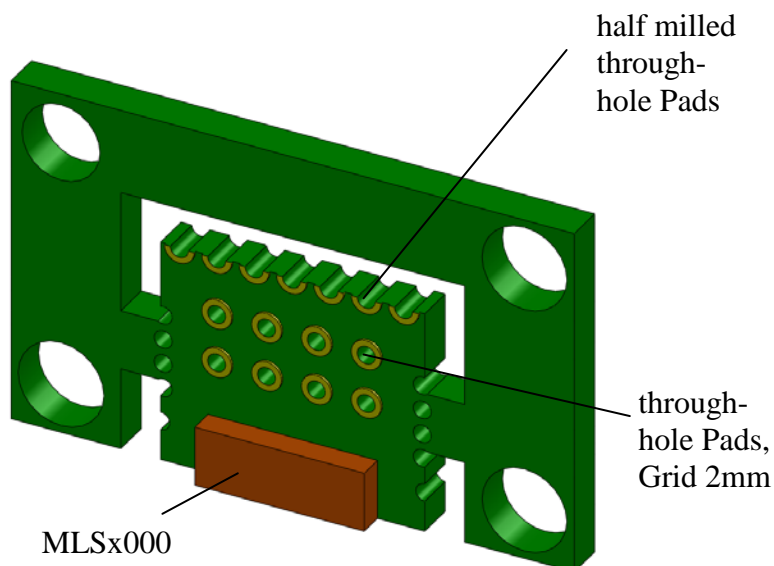
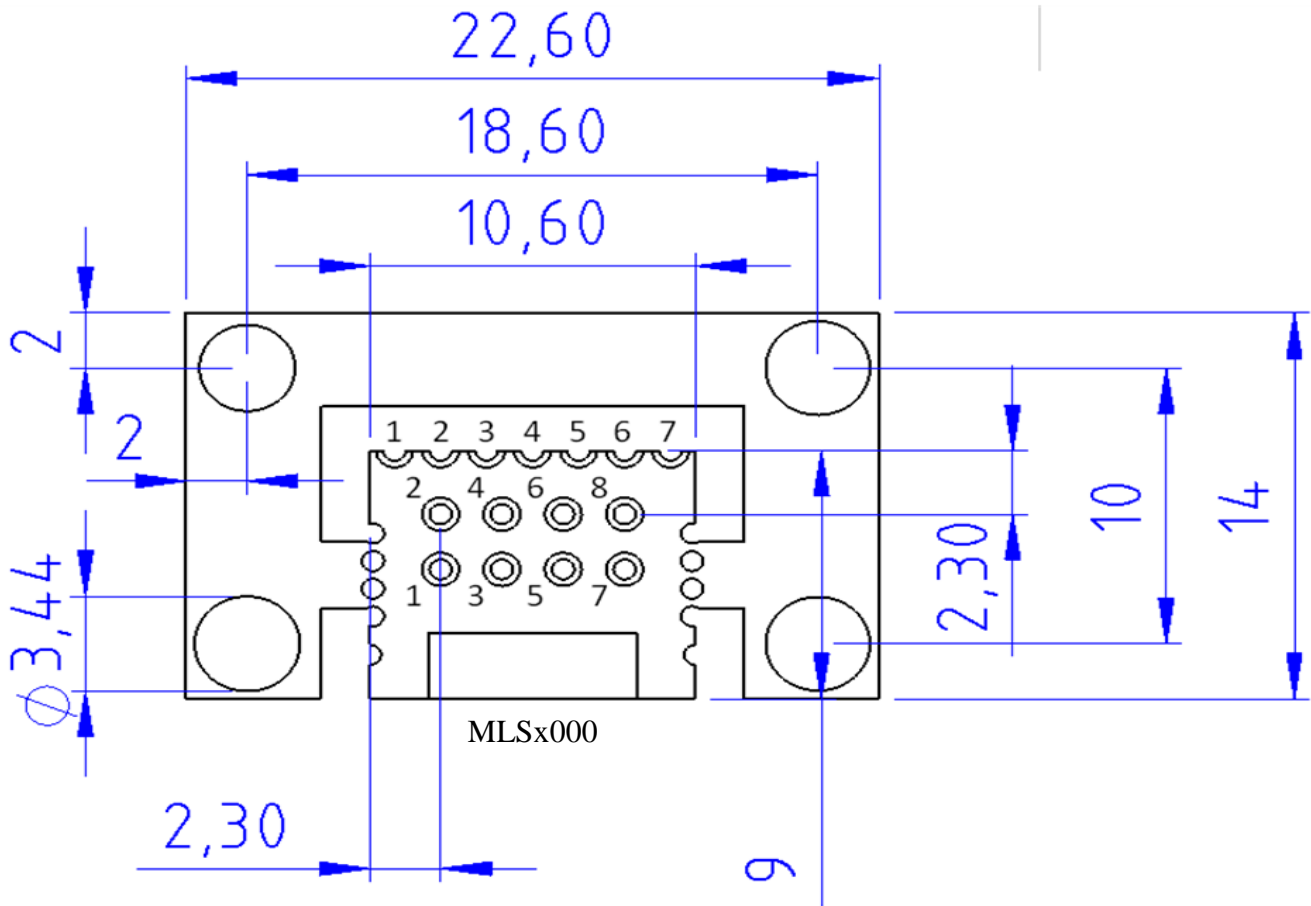

Pin	Annotation	Name
1	Ground	Gnd
2	Output signal	$V_{\cos+}$
3	Output signal	$V_{\sin+}$
4	Supply voltage	$V_{cc2}$
5	Output signal	$V_{\sin-}$
6	Output signal	$V_{\cos-}$
7	Supply voltage	$V_{cc1}$

# Magnetic Length Sensor MLS (Hybrid)

## APPLICATION EXAMPLE

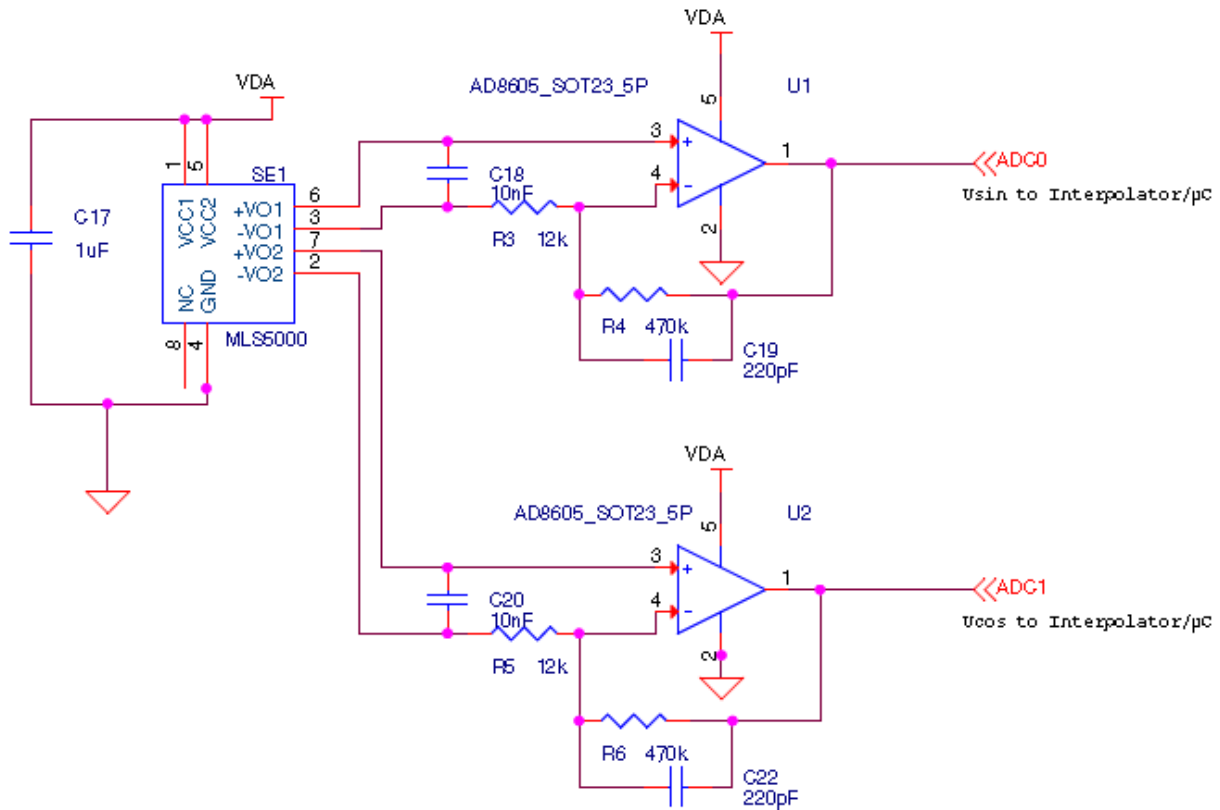

Exemplary hardware configuration using an Analog Devices AD8605 amplifier for preprocessing MLS5000 signals for usage with common Microcontroller

## TEST REQUIREMENTS

The parameters of the MLS sensor are measured in combination with a magnetic scale. The magnetic scale consists of magnetic rubber material, bonded on a steel carrier. The pole pitch of the scale has to match to the sensor type (see characteristic values). MEAS can provide short strips of scales for reference.

The maximum used air gap between the sensor module and the scale has to match the sensor type and not exceed:

- MLS1000: 0.5mm
- MLS2000: 1mm
- MLS5000: 2.5mm
- MLS8: 1.25mm

Test temperature: 25°C

MEAS recommends the use of IC-Haus IC-NQ ASIC for signal evaluation.

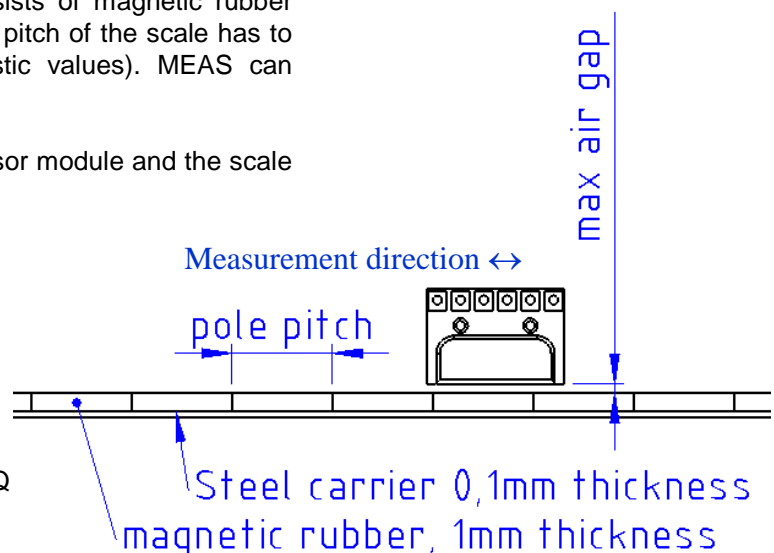



# Magnetic Length Sensor MLS (Hybrid)

---

## ORDERING CODES

---

	<b>MLS1000</b>	<b>MLS2000</b>	<b>MLS5000</b>	<b>MLS8</b>
<b>Large hybrid (HS)</b>	<i>on request</i>	<i>eng. samples</i>	<b>G-MRCO-012</b>	<i>eng. samples</i>
<b>Small hybrid (HK)</b>	<i>on request</i>	<i>eng. samples</i>	<b>G-MRCO-013</b>	<i>eng. samples</i>
<b>2side hybrid (HD)</b>	<b>G-MRCO-038</b>	<b>G-MRCO-039</b>	<b>G-MRCO-040</b>	<b>G-MRCO-041</b>

---

## 联系方式



深圳市亿为测控电子有限公司  
Shenzhen Bill-Well Measurement & Control Electronics Co., Ltd.

广东省深圳市南山区创业路怡海广场东座2407 邮编：518000

电话：+86 755 2641 9890 传真：+86 755 2641 9680

电子邮箱：sales@bill-well.com