

MS32 Switching Sensor



- AMR Switching-Sensor
- TDFN Outline 2.5x2.5x0.8 mm³
- Temperature Compensated Switching Point
- Low Power Consumption

DESCRIPTION

The MS32 is a magnetic field sensor which is built in the form of a Wheatstone bridge. Each of its four resistors is made from *Permalloy*, a material that shows the *anisotropic magneto resistance effect*. An unidirectional magnetic field in the surface parallel to the chip (x-y plane) along the y-axis will deliver a field dependent output signal. A **magnetic switching point**, which is almost **independent on temperature** is typically set to $H_s=1.85$ kA/m. In addition, the characteristic curve is linear over a wide magnetic field range. Thus, the new MS32 simplifies the adaption of the sensor to different mechanical and magnetical environments. The sensor die is packaged in a modern TDFN package.

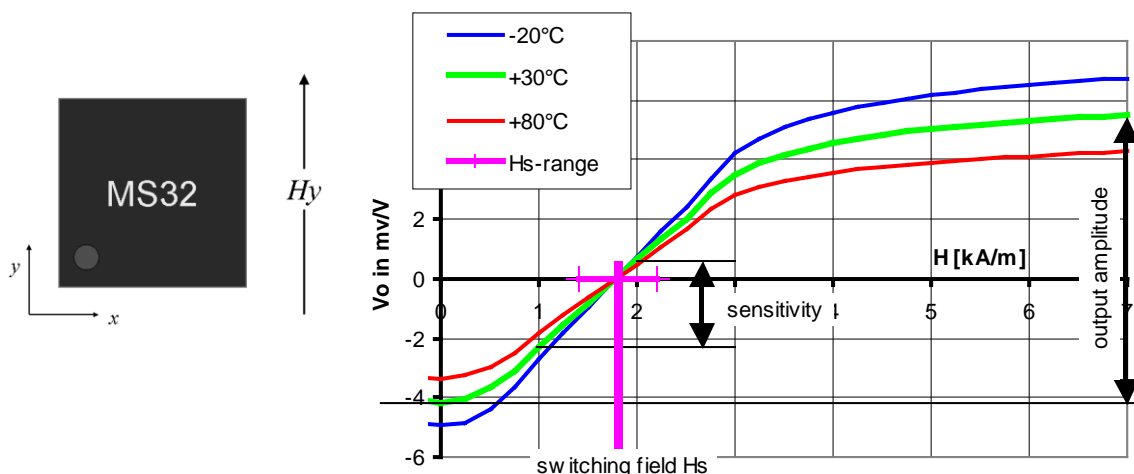

Figure 1: Characteristic curves for MS32 at different ambient temperatures (-20°C, +30°C, +80°C)

FEATURES

- Sensor based on solid state magnetoresistance effect
- Unipolar signal output
- Linear field response
- High sensitivity, low hysteresis
- Temperature compensated switching point
- Low power consumption due to high bridge resistance
- Supply voltage up to 30 V
- Small TDFN package

APPLICATIONS

- Contactless position detection (presence, open/close)
 - Industrial
 - Consumer
 - Automotive
- Applications, like:
- Small stroke pneumatic cylinders
 - Cover positions of Notebooks and Mobiles
 - Doors, windows etc.

MS32 Switching Sensor

CHARACTERISTIC VALUES

Parameter	Condition	Symbol	Min	Typ	Max	Unit
Mechanical dimensions						
Length		X		2.5		mm
Width		Y		2.5		mm
Height		Z		0.75		mm
Pad size	7)			0.25 x 0.30		mm ²
Operating limits						
Max. supply voltage		V _{CC, MAX}			30	V
Operating temperature		T _{OP}	-25		+85	°C
Storage temperature		T _{ST}	-25		+125	°C

Stress above one or more of the limiting values may cause permanent damage to the device. Exposure to limiting values for extended periods may affect device reliability.

Parameter	Condition	Symbol	Min	Typ	Max	Unit
Sensor specification (V_{CC} = 5 V, T = 30 °C)						
Supply voltage		V _{CC}		5	30	V
Resistance		R _B	10300	11500		Ω
Offset		V _{OFF} /V _{CC}		-4	-1.5	mV/V
Sensitivity	1)	S	2	3		(mV/V)/(kA/m)
Output amplitude	2)	V _{MAX}	8			mV/V
Hysteresis (@ V ₀ =0) 3)		Hyst.			0.9	mV/V
Sensor specification (T = -25 °C; +85 °C; Conditions A & B) 6)						
TC of amplitude		TCSV	-0.36	-0.32	-0.28	%/K
TC of bridge resistance		TCBR	+0.27	+0.32	+0.37	%/K
Switching field 5)	4)	H _s	1.40	1.85	2.30	kA/m

All parameters are measured on wafer level.

- 1) average gradient in the range 1.0 - 2.0 kA/m
- 2) difference between output voltage/supply voltage measured at H = 7 kA/m and H = 0 kA/m
- 3) hysteresis [in kA/m] = hysteresis [in mV/V] / S
- 4) switching voltage = 0 mV/V
- 5) switching field = magnetic field at switching voltage
- 6) values at -25°C can be determined by linear extrapolation from +30°C- and +85°C-values.
- 7) recommended solder reflow process according to IPC/JEDEC J-STD-020D (Pb-Free Process)

MS32 Switching Sensor

MEASUREMENT CONDITIONS

Parameter	Symbol	Unit	Condition
A. Set Up Conditions			
ambient temperature	T	°C	T = 23 +/- 5 °C (unless otherwise noted)
supply voltage	V _{CC}	V	V _{CC} = 5 V
applied magnetic field	H _Y	kA/m	H _Y = -7 .. +7 kA/m; along y-direction; H _X < 100 A/m Pre-magnetization along x-direction with H _X >= 3 kA/m
B. Parameter Definitions (T= -25 °C, +85 °C) see characteristic values ⁶⁾			
ambient temperatures	T	°C	T ₁ = -25 , T ₀ = +30 , T ₂ = +85 °C
TC of amplitude	TCSV	%/K	$TCV = \frac{1}{(T_2 - T_1)} \cdot \frac{V_a(T_2) - V_a(T_1)}{V_a(T_1)} \cdot 100\%$
TC of resistance	TCBR	%/K	$TCR = \frac{1}{(T_2 - T_1)} \cdot \frac{R(T_2) - R(T_1)}{R(T_1)} \cdot 100\%$
TC of offset	TCV _{OFF}	μV/(VK)	$TCV_{off} = \frac{V_{off}(T_2) - V_{off}(T_1)}{(T_2 - T_1)}$

BLOCK DIAGRAM

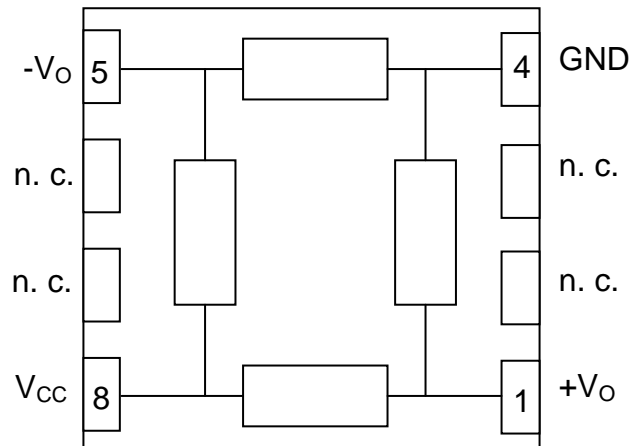

Figure 2: internal and external connections (TDFN, Chip)

MS32 Switching Sensor

SENSOR OUTLINE

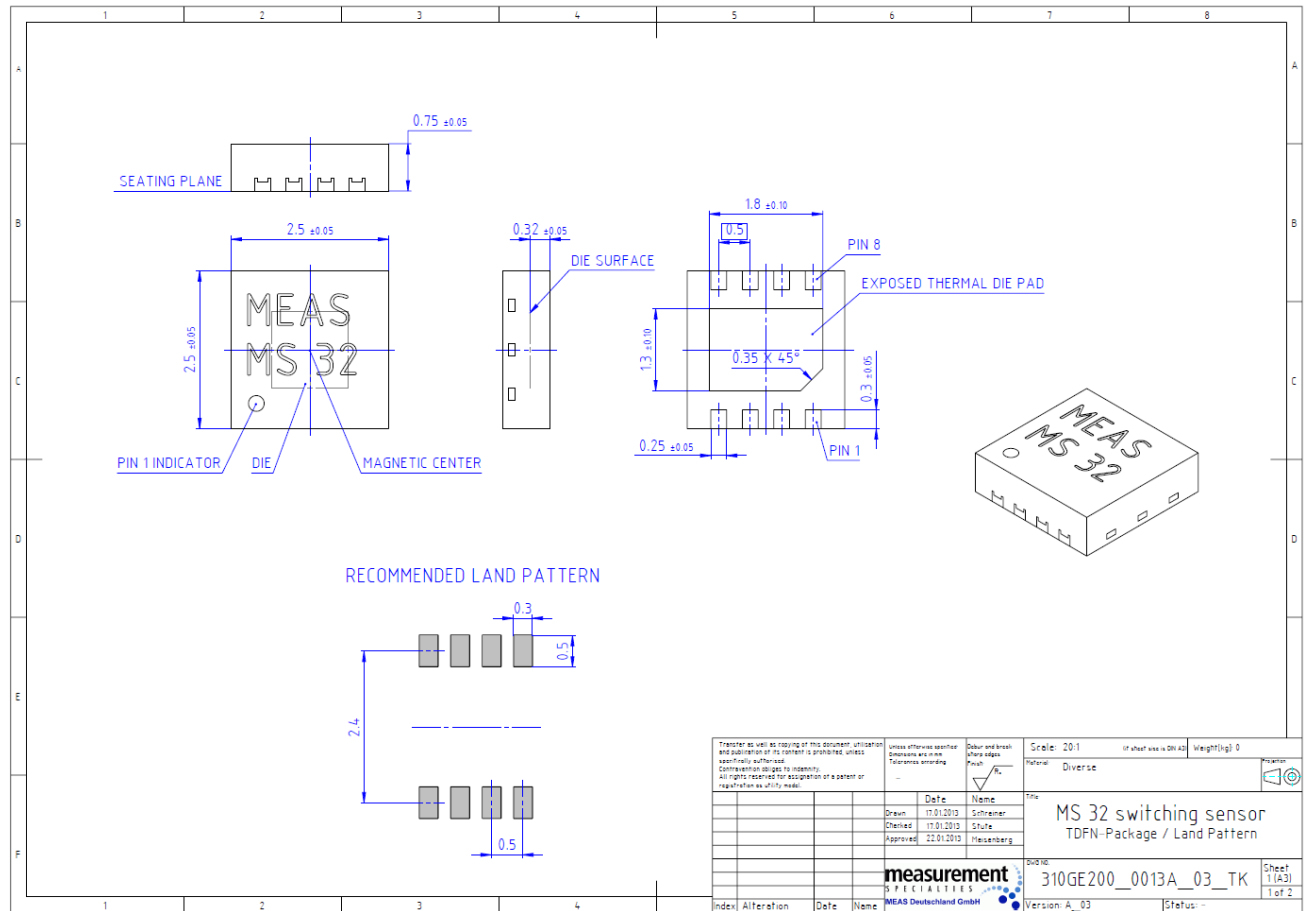

Figure 3: TDFN-package outline and recommended land pattern

Pin assignment:

Pin	Symbol	Function
1	+V _O	positive output bridge
2	n. c.	not connected
3	n. c.	not connected
4	GND	ground
5	-V _O	negative output bridge
6	n. c.	not connected
7	n. c.	not connected
8	V _{CC}	supply voltage bridge

Note:

Pin 1 position is marked by a dot on the top side and by the chamfered corner of the bottom plate. The bottom plate is designated to be a heat sink. It has no electrical connection to any pin. The sensitive area is positioned in the center of the package.

MS32 Switching Sensor

APPLICATION

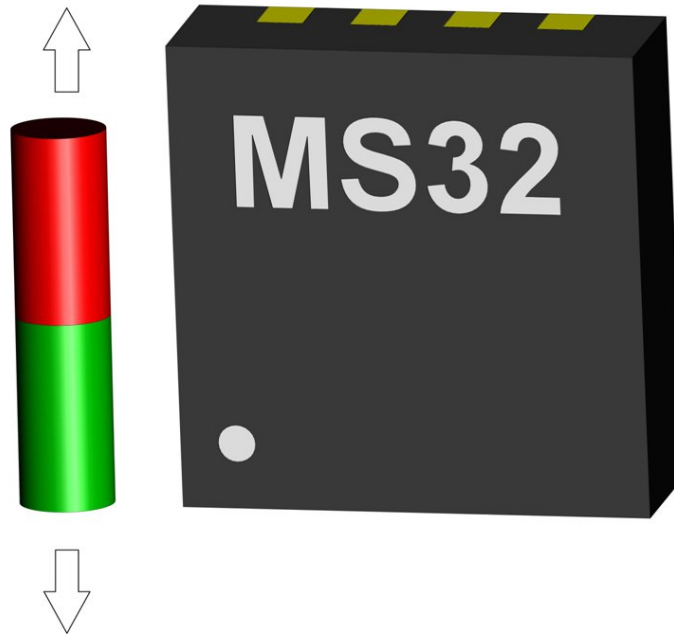

Figure 4: Typical application geometry of MS32

CIRCUIT EXAMPLES

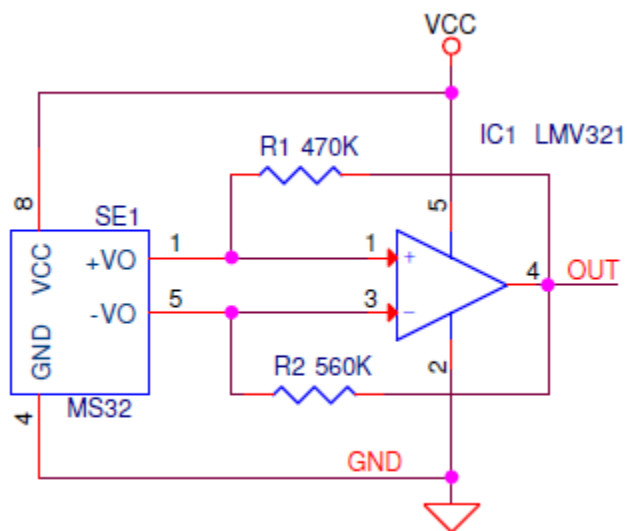

Figure 5: Switching point detection without hysteresis

MS32 Switching Sensor

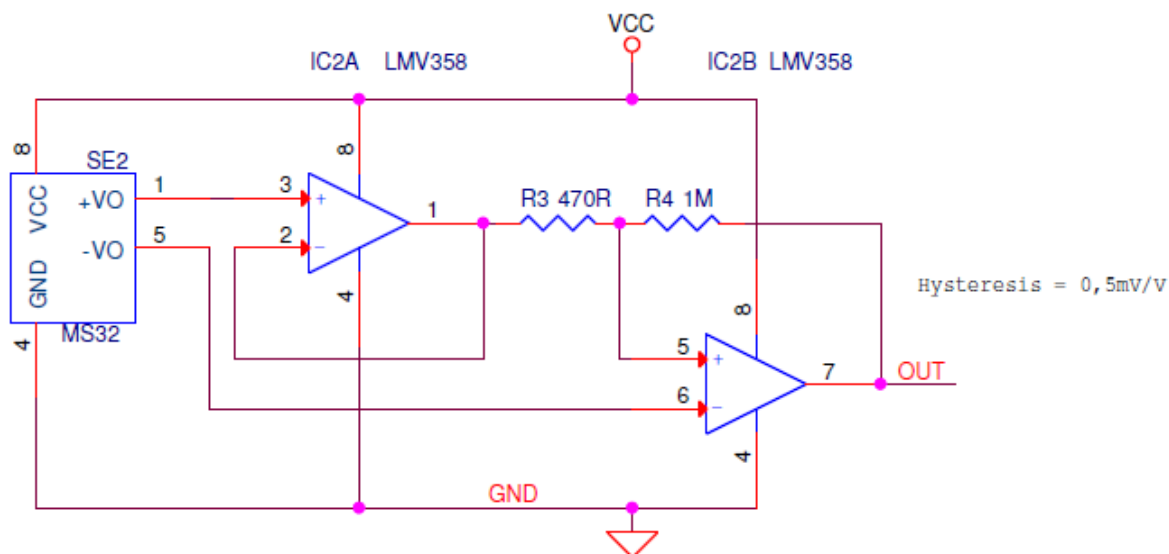

Figure 6: Switching point detection with hysteresis

TAPE AND REEL PACKAGING INFORMATION

Description	Reel size	Units/reel	Pin 1 orientation	Note
MS32	7"	3,000	Top-right of sprocket hole side	

ORDERING CODE

Device	Package	MOQ	Part number
MS32 die	Wafer / undiced	1 wafer	on request
MS32	TDFN 2.5 x 2.5	1 reel	G-MRCO-017

联系方式



深圳市亿为测控电子有限公司
Shenzhen Bill-Well Measurement & Control Electronics Co., Ltd.

广东省深圳市南山区创业路怡海广场东座2407 邮编：518000
电话：+86 755 2641 9890 传真：+86 755 2641 9680
电子邮箱：sales@bill-well.com