

# KMA36 universal magnetic encoder



- Contactless Absolute 360° (180°) angle measurement
- Incremental mode
- Linear mode
- Standard I2C Interface (100 kHz)
- Programmable resolution up to 13 bit (0.04 degree)
- Very low hysteresis
- High accuracy mode
- User programmable parameters
- Low power mode
- Sleep and automatic wake-up over I2C
- Programmable zero position
- Device address hardware configurable
- Small Pb-Free package (TSSOP20)
- RoHS compliant

## DESCRIPTION

The KMA36 is a universal magnetic encoder for precise rotational or linear measurement. These digital position sensors feature a system-on-chip technology that combines a magnetoresistive element along with analog to digital converter and signal processing in a standard small package. By using Anisotropic Magneto Resistive (AMR) technology, the KMA36 is able to determine contactlessly the magnetic angle of an external magnet over 360°, as well as the incremental position on a magnetic pole strip with 5 mm pole length. Its sleep and low power mode as well as automatic wake-up over I2C – make the KMA36 ideal for many battery applications. Position data can be transmitted using a PWM or digital two-wire (SDA, SCL) communication bus. Using the programmable parameters of this digital position sensor, the user can have access to a wide range of configuration to ensure the maximum of freedom and functionalities.

Used as both a linear position sensor or a rotary position sensor, these KMA36 magnetoresistive sensors designed by MEAS (Measurement Specialties) are insensitive to magnetic drift due to mechanical tolerances, changes in temperature or thermal stress. The maintenance-free operation and high bandwidth of this universal magnetic encoder and Position Sensor makes it a good choice for dynamic applications in harsh environments. Measurement Specialties designed the universal magnetic encoder KMA36 to replace the less precise Hall-Effect position sensors that are often susceptible to external noise. As a robust Position Sensors the Measurement Specialties KMA36 can also replace more fragile optical encoders whose bearings are subject to failure.

## KEY-FEATURES

<b>Resolution</b>	<b>13 Bit / 0.04 degree</b>
<b>Operating power supply range of 3V to 5.5V</b>	<b>3.0 – 5.5V</b>
<b>Operating temperature</b>	<b>- 25 - +85 °C</b>
<b>Average current</b>	<b>10 – 30 mA</b>
<b>Sleep current</b>	<b>1.2 mA</b>
<b>Data Update rate</b>	<b>24 – 720 Hz</b>
<b>I<sup>2</sup>C Clockrate</b>	<b>Up to 100 kBit/s</b>

## APPLICATIONS

Industrial environment  
Harsh environment  
Handling machine  
Machine tools

Robotics  
Potentiometer  
Motor motion control

# KMA36 universal magnetic encoder

## PIN ASSIGNMENT

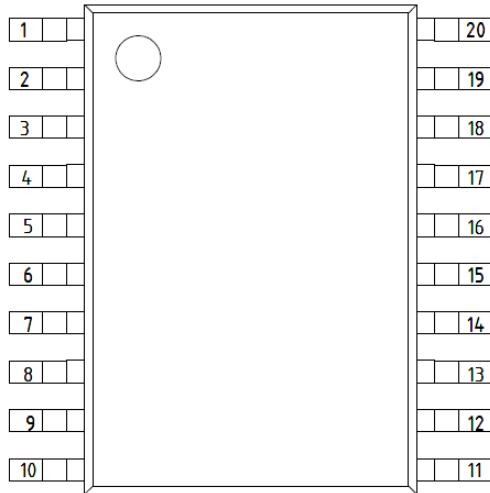

Pin No. KMA36 TSSOP	Symbol	Type	Description
1	A1	NC	Not connected
2	A0	I	Slave address configuration pin
3	DVCC_SE	O	Drive pin to power sensor
4	SDA	I/O	Two-wire interface data pin
5	PWM	O	PWM output
6	SCL	I	Two-wire interface clock pin
7	GND_SE	S	Sensor supply ground pin
8	VCC_SE	S	Sensor power supply pin
9	NC	NC	Not connected
10	NC	NC	Not connected
11	NC	NC	Not connected
12	COILP	I	Coil power supply pin
13	COILN	I	Coil power supply pin
14	AREF	I	Asic analog reference
15	NC	NC	Not connected
16	GND_AS	S	Asic supply ground
17	NC	NC	Not connected
18	VCC_AS	S	Asic power supply
19	DCOILN	O	Drive pin to coil power supply
20	DCOILP	O	Drive pin to coil power supply

Figure 1: Pin assignment

## ELECTRICAL CHARACTERISTICS

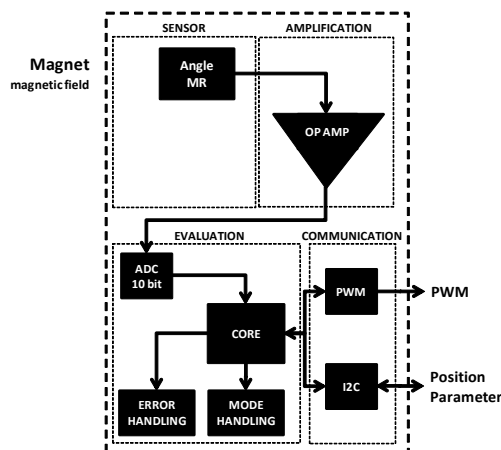

Unless otherwise specified, all voltages are referenced to the power ground supply VSS. Typical values are based on  $T_{op} = 25\text{ }^{\circ}\text{C}$ ,  $V_{CC} = 5\text{ V}$ . They are given only as design guidelines and are not tested in production. Data based on characterization results, design simulation and/or technology characteristics are indicated in the table footnotes and are not tested in production.

Absolute maximum ratings are limiting values of permitted operation and should never be exceeded under the worst possible conditions either initially or consequently. If exceeded by even the smallest amount, instantaneous catastrophic failure can occur. And even if the device continues to operate satisfactorily, its life may be considerably shortened.

Figure 2: Functional block description

# KMA36 universal magnetic encoder

## Absolute maximum ratings

CAUTION: Exceeding these values may destroy the product.

Symbol	Parameter	Condition	Min.	Typ.	Max.	Unit
T <sub>op</sub>	Operating temperature		- 25		+ 85	°C
T <sub>sto</sub>	Storage temperature		- 40		+ 85	°C
V <sub>cc</sub>	Operating voltage		2.9		6	V
V <sub>in</sub>	Input voltage on any Pin	Except on A1	-0.5		6.5	V
V <sub>in</sub>	Input voltage on A1		-0.5		13	V
I <sub>in</sub>	DC Current through any I/O Pin				40	mA
I <sub>in</sub>	DC Current through S Pin				200	mA
I <sub>in</sub>	DC Current through any C Pin				60	mA

**Table 1:** Absolute maximum ratings

## • Operating conditions

Symbol	Parameter	Condition	Min.	Typ.	Max.	Unit
T <sub>op</sub>	Operating temperature		- 25		+ 85	°C
V <sub>cc</sub>	Operating voltage		3		5.5	V
V <sub>in</sub>	Input voltage on I/O pin		-0.3		5.3	V
A <sub>Ref</sub>	External Analog Reference		2.0 <sup>1)</sup>		V <sub>cc</sub>	V
R <sub>AREF</sub>	Analog Reference input resistance		-	32	-	kΩ

**Table 2:** Operating conditions

<sup>1)</sup> Apply 2.0V at AREF for best results

Please refer to the typical application section to know which external components should be connected.

## • AC/DC characteristics

Symbol	Parameter	Condition	Min.	Typ.	Max.	Unit
I <sub>avg</sub>	Average current <sup>1)</sup>	Except in sleep mode, V <sub>cc</sub> = 5V	10		30	mA
I <sub>sleep</sub>	Sleep current	V <sub>cc</sub> = 5V		1.2		mA
V <sub>IL</sub>	Input low voltage	V <sub>cc</sub> = 5V, I <sub>OL</sub> = 10 mA			0.6	V
V <sub>IH</sub>	Input high voltage	V <sub>cc</sub> = 5V, I <sub>OH</sub> = 10 mA	3			V
V <sub>OL</sub>	Output low voltage	V <sub>cc</sub> = 5V, I <sub>OL</sub> = 10 mA			0.6	V
V <sub>OH</sub>	Output high voltage	V <sub>cc</sub> = 5V, I <sub>OH</sub> = 10 mA	4.3			V

**Table 3:** AC/DC characteristics

<sup>1)</sup> Current measurement has been done with a standard circuit including a voltage divider on AREF.

# KMA36 universal magnetic encoder

- **System parameters**

Symbol	Parameter	Condition	Min.	Typ.	Max.	Unit
$f_{data}$	Update rate <sup>1) 2)</sup>		24		720	Hz
$t_{start}$	Starting time			5		ms
$\alpha_r$	Resolution	$H_0=25 \text{ kA/m}$ <sup>3)</sup>		13		Bit
$\Delta\alpha_L$	Linearity error	$H_0=25 \text{ kA/m}$ <sup>3)</sup>		$\pm 0.3$	$\pm 1$	°
$\Delta\alpha_H$	Hysteresis error	$H_0=25 \text{ kA/m}$ <sup>3)</sup>		$\pm 0.1$	$\pm 0.25$	°
$V_{bwn}$	Brown-out reset voltage			2.7		V
$t_{bwn}$	Brown-out reset pulse width			2		µs
$H_y$	Applied magnetic field		15	25	60	kA/m
$R_{COIL}$	Internal coil resistance		75	100	150	Ω
$\Delta_{PWM}$	PWM output resolution			10		bit
$f_{PWM}$	PWM frequency			7.8		kHz

**Table 4:** System parameters

- 1) Maximum is measured in speed mode with minimum oversampling. Minimum is measured with maximum oversampling.  
 2) When using the analog-output configuration then update rate is fixed at 88Hz  
 3) System parameters apply only for recommended measurement setup (please refer to the arrangement section)

Update rate	
$f_{data} = 1 / (1.4 \text{ msec} \times \text{oversampling} / \text{const})$	
SPD Bit	const
0	1
1	2

## SYSTEM OUTPUT

The system has two possible hardware output configurations: two-wire interface or analog output.

- **Analog Output**

The system has a Pulse Width Modulation unit with 10 bit resolution which can be easily coupled with a first order low-pass filter<sup>1)</sup> to generate an analog output between  $V_{ss}$  and  $V_{cc}$  corresponding to  $0^\circ$  and  $360^\circ$ . In this hardware configuration, all internal registers are loaded with initial values. No digital configuration is necessary, all available configurations can be set by changing the hardware setup<sup>2)</sup> of the KMA36.

- 1) Please refer to the typical application section for further information.  
 2) Please refer to the hardware configuration section for further information.

- **I<sup>2</sup>C (Digital Output)**

The KMA36 has an I<sup>2</sup>C Interface unit (two-wire interface, standard I<sup>2</sup>C-bus specification defined by Philips Semiconductors) with an 8-bit data bus which can be easily used to retrieve measurement and configuration information. (Please refer to the two-wire interface section for details)

# KMA36 universal magnetic encoder

## TWO WIRE IN INTERFACE

- Physical interface parameters

Symbol	Parameter	Condition	Min.	Typ.	Max.	Unit
$B_{rt}$	Clockrate		10	50	100	kBit/s
$A_L$	Address length			7		bit
$A_S$	Address <sup>1)</sup>			0x59		Hex

**Table 5:** Physical interface parameters

<sup>1)</sup> Please refer to the hardware configuration section to determine how to configure other addresses.

- Timing parameters

Symbol	Parameter	Condition	Min.	Typ.	Max.	Unit
$t_{SU:STA}$	Start setup time		4.7			$\mu$ s
$t_{HD:STA}$	Start hold time		4.0			$\mu$ s
$t_{SU:STO}$	Stop setup time		4.0			$\mu$ s
$t_{HIGH}$	Clock high time		4.0		50	$\mu$ s
$t_{LOW}$	Clock low time		4.7			$\mu$ s
$t_r$	Rise time				1	$\mu$ s
$t_f$	Fall time				0.3	$\mu$ s
$t_{SU:DAT}$	Data input setup time		0.25			$\mu$ s
$T_{HD:DAT}$	Data input hold time		0.3			$\mu$ s
$t_{BUF}$	Bus free time		4.7			$\mu$ s

**Table 6:** Start, stop and data timing parameters

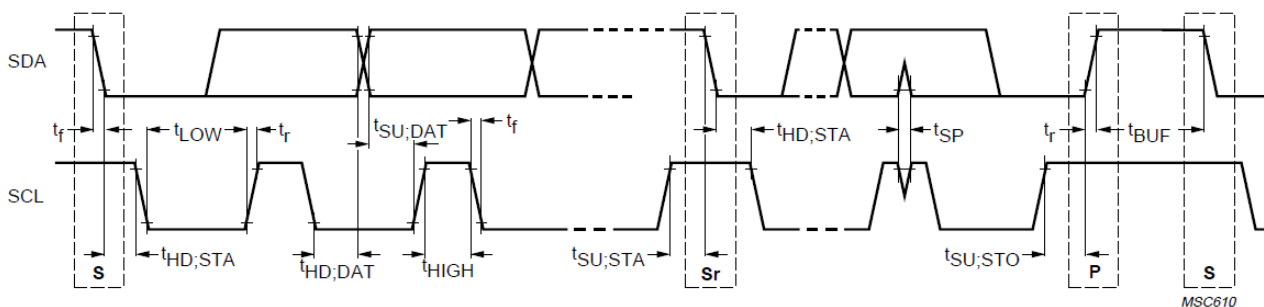

**Figure 3:** Timing definitions<sup>2)</sup>

<sup>2)</sup> Please refer to the standard I<sup>2</sup>C-bus specification defined by Philips Semiconductors for further information.

# KMA36 universal magnetic encoder

- **Registers (Overview)**

The KMA36 contains the following I/O registers:

Registers of the KMA36			
Register	Size	Read/Write	Function
KCONF	8 bit	R/W	Configuration bits
KRES	16 bit	W	Resolution
MA	16 bit	R	Magnetic angle
ILC	32 bit	R	Incremental counter

**Table 7:** Registers of the KMA36

- **I<sup>2</sup>C Bus**

The KMA36 is always operating as a pure slave.

- **I<sup>2</sup>C Reading data**

It is possible to read up to seven bytes as described in the following figure. No special protocol is used by the reading-data process.

TWI - Read data							
Byte	0	1	2	3	4	5	6
	MA0	MA1	ILC0	ILC1	ILC2	ILC3	KCONF
Read/Write	R	R	R	R	R	R	R
Initial value	0x00	0x00	0x00	0x00	0x00	0x00	0x03

Byte 0:1 - MA1:0: Magnetic angle

Unsigned integer giving the magnetic angle in degree with the configured resolution

Byte 2:5 - ILC3:0: Incremental linear counter

Signed long giving the incremental linear counter in degree with the configured resolution.

Byte 6 - KCONF: Configuration register

Unsigned char giving the configuration register value.

**Table 8:** Read data

- **I<sup>2</sup>C Writing data (general)**

The KMA36 can be controlled using two internal registers. The configuration (KCONF) is an 8-bit register and the resolution (KRES) is a 16-bit register. To write the 16-bit register (KRES) through the two-wire interface with an 8-bit data bus, it is necessary to send the high byte first and then the low byte.

In order to change the KMA configuration, four bytes should be sent through the two-wire 8-bit data bus. The first three bytes correspond to the configuration and resolution registers. The last byte contains a 8-Bit Cyclic Redundancy Check (CRC) value which can be calculated as described in the example.

# KMA36 universal magnetic encoder

TWI - Send data				
Byte	0	1	2	3
	KCONF	KRESH	KRESL	KCRC
Read/Write	W	W	W	W
Initial value	-	-	-	-

Byte 0: KCONF: Configuration register  
Contains the desired system configuration.

Byte 1:2 - KRES: Resolution register  
Contains the desired resolution.

Byte 3 - KCRC: CRC  
Contains the cyclic redundancy check.

**Table 9:** Send data

## Example

	KCONF	KRESH	KRESL	KCRC
data	0x03	0x7F	0xFF	0x7F
	$\boxed{\text{KCRC}} = 0xFF - (\text{KCONF} + \text{KRESH} + \text{KRESL}) + 0x01$			
	$\boxed{\text{KCRC}} = 0xFF - (0x03 + 0x7F + 0xFF) + 0x01 = 0x7F$			

**Table 10:** CRC Example

# KMA36 universal magnetic encoder

- **KCONF (Configuration register)**

The configuration register is used to control and monitor the status and modes of the system:

KCONF - Configuration register								
Bit	7	6	5	4	3	2	1	0
	SLP	-	LIN	CNT	PWR	SPD	OVCS1	OVSC0
Read/Write	W	R/W	R/W	R/W	R/W	R/W	R/W	R/W
Initial value	0	0	0	0	0	0	1	0

Bit 7 - SLP: Sleep mode

Writing this bit to one enables the sleep mode. This bit will be always set to zero by hardware.

Bit 5 - LIN: Mode

Writing this bit to one disables the rotational mode and enables the linear mode.

Bit 4 - CNT: Mode

Writing this bit to one enables the incremental counter mode. By writing it to zero, the counter mode is turned off.

Bit 3 - PWR: Low power mode

Writing this bit to one enables the low power mode.

Bit 2 - SPD: Speed mode

Writing this bit to one enables the fast speed mode.

Bit 1:0 - OVCS1:0: Oversampling

These bits determines the accuracy of the angle evaluation.

**Table 11:** KCONF – Configuration Register

The system has three possible main configurations:

- **Rotational measurement** used to measure the angle of a rotating magnet disc centered above the magnetic sensor center of the KMA36. <sup>1)</sup>
- **Linear measurement** used to measure the linear movement of the KMA36 along a magnetic pole strip with 5mm pole length. A lookup table is used for internal error correction <sup>1)</sup>
- **Sleep mode communication** used to power down the KMA36. Wake up is initiated by I<sup>2</sup>C

<sup>1)</sup> Please refer to the arrangement section.

- **CNT-Bit (KCONF register)**

In addition, there is an incremental counter implemented, which can be enabled by writing a one to the CNT-Bit in the KCONF register.



# KMA36 universal magnetic encoder

- **SPD-Bit (KCONF register)**

The measurement update rate can be increased by activating the fast mode with SPD bit. In fast mode measurement accuracy is reduced.

Update rate	
$f_{data} = 1 / (1.4 \text{ msec} \times \text{oversampling} / \text{const})$	
SPD Bit	const
0	1
1	2

**Table 12:** Update rate

- **PWR-Bit (KCONF register)**

The power current consumption can be reduced with the low power mode accessible through the PWR bit. In low power mode only **180°** measurement are possible.

- **OVCS-Bits (KCONF register)**

To increase the measurement accuracy, it is possible to configure the oversampling rate by using the OVSCx bits. Please notice that a higher accuracy leads to a reduction of the update rate (Please refer to the Update rate table)

OVCS1	OVSC0	Oversampling
0	0	2
0	1	4
1	0	8
1	1	32

**Table 13:** OVSC - Oversampling

- **KRES (Resolution register)**

The resolution can be set to any decimal value between 1 and 32768. Any other value would lead to unexpected system behavior.

KRES - Resolution register								
Bit	15	14	13	12	11	10	9	8
KRESH	KRES15	KRES14	KRES13	KRES12	KRES11	KRES10	KRES9	KRES8
KRESL	KRES7	KRES6	KRES5	KRES4	KRES3	KRES2	KRES1	KRES0
Bit	7	6	5	4	3	2	1	0
Read/Write	W	W	W	W	W	W	W	W
Initial value	0	1	1	1	1	1	1	1
	1	1	1	1	1	1	1	1

**Table 14:** KRES - Resolution Register

For example, a resolution of decimal 360 (0x00168) leads to rotational data in steps of 1 degree. A resolution of decimal 3600 (0x0E10) results in steps of 0.1°.

# KMA36 universal magnetic encoder

## HARDWARE CONFIGURATION

The hardware configuration depends on the desired output: two-wire interface or analog.

In two-wire interface configuration, the slave address of the system can be configured by connecting A0 and another pin as described in following table.

### TWI - Slave address configuration

Address	Connection	
0x59	A0	GND
0x5A	A0	DCOILP
0x5B	A0	DCOILN
0x5C	A0	DVCC_SE
0x5D	A0	VCC

**Table 15:** TWI / I<sup>2</sup>C Slave address configuration

In analog mode, the rotation direction can be configured by connecting DVCC\_SE and a power supply pin. The user zero reference angle calibration can be activated by connecting A0 and COILP. When the user zero reference angle calibration is active, the next evaluated magnetic angle will be set as the new zero reference angle. The user selectable output voltage for the zero reference angle can be configured by connecting A0 in series with a 4,7k ohm resistor and a port pin. The percentage indicated is relative to the power supply value Vcc and is defined at the zero reference angle position.

### ANALOG - Rotation direction configuration

Direction	Connection	
CW	DVCC_SE	VCC
CCW	DVCC_SE	4,7K to GND

### ANALOG - User selectable output for zero reference

Percent	Connection	
0%	A0	4,7K to VCC
10%	A0	4,7K to DVCC_SE
25%	A0	4,7K to DCOILN
50%	A0	4,7K to GND

### ANALOG - Zero reference angle user calibration

Status	Connection	
Active	A0	COILP
Inactive	A0	-

**Table 16:** Analog-Mode configuration

# KMA36 universal magnetic encoder

## TYPICAL APPLICATION

- Electrical circuit

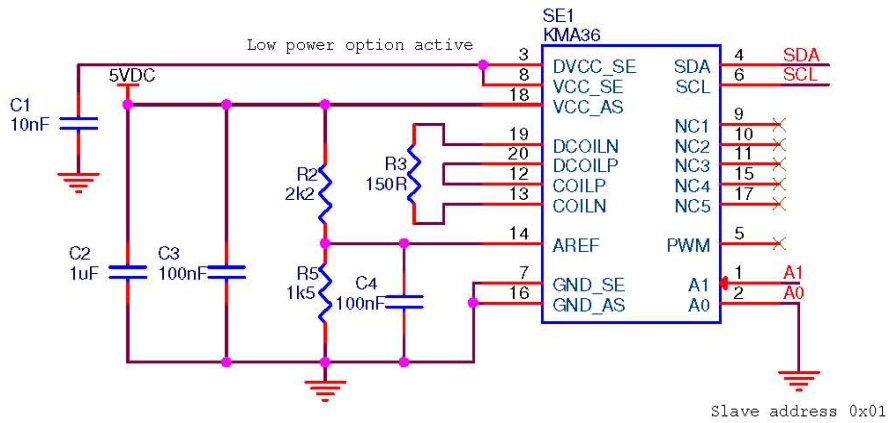

**Figure 4:** Typical circuit with two-wire interface

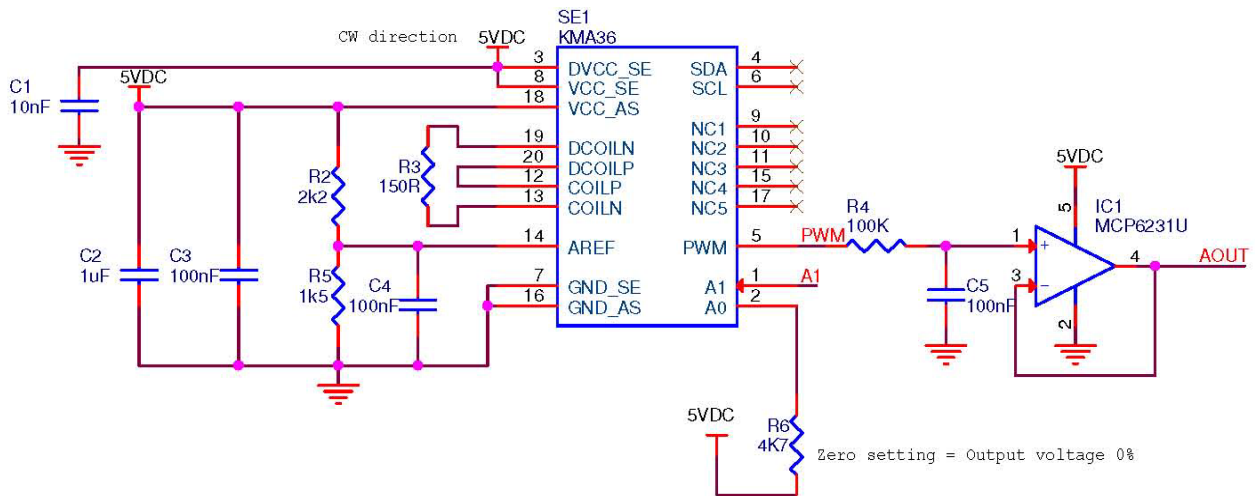

**Figure 5:** Typical circuit with analog interface

# KMA36 universal magnetic encoder

## ARRANGEMENT

Due to the magneto resistive technology which senses the magnetic field in the sensor plane, it is advised to mount the magnet disc centered above the sensor center. Please refer to the magnets and scales section for more information about the magnetic center position of the KMA36. The magnetic scale should be placed perpendicularly to the KMA36 as depicted in the following figure rather in the middle along the width of the scale. For best results the KMA36 should be as close as possible to the magnet.

- **Rotational (recommended) setup (for best results)**



Rotational mode  
Bit LIN = 0

**Pay attention to the magnetic center of the KMA36**

- **Linear setup**

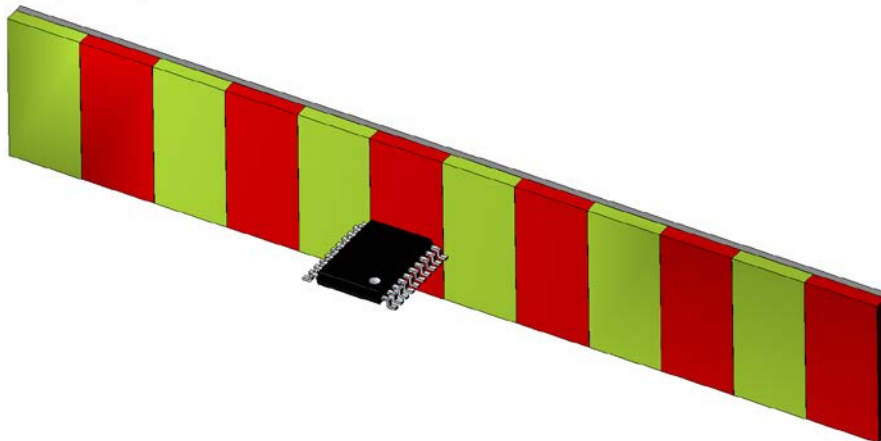

Linear mode  
Bit LIN = 1

**use magnetic pole strip with 5mm pole length for best results**

**Figure 6:** Mounting

# KMA36 universal magnetic encoder

## MAGNETS AND SCALES

### Rotational Mode

The KMA36 can be used with a magnet, preferably of disc or square shape or a magnet scale with pole pitch 5mm.

For development purposes, MEAS offers a magnet disc made of plastic bonded Nd-Fe-B magnetic material which provides an homogenous magnetic field with sufficient magnetic field strength for typical application with the KMA36. The following table describes typical magnets parameters. Please refer to the website <http://www.magnetfabrik.de> (article number 67.044-1 ) and its application note section for more information.

Symbol	Parameter	Condition	Min.	Typ.	Max.	Unit
Ø	Diameter	Neofer 48/60p only		14		mm
T	Thickness	Neofer 48/60p only		2.5		mm
B <sub>r</sub>	Magnetic field strength	Neofer 48/60p only		540		mT
T <sub>op</sub>	Operating temperature	Neofer 48/60p only			150	°C

**Table 17a:** Typical MEAS disc-magnet specification

### Linear Mode

The linear mode of the KMA36 is designed for a magnetic scale with pole pitch 5mm. A magnetic scale is made of a magnetic ferrite tape bonded on a steel support which guarantees mechanical stability. The steel support is made of an optimum stainless steel alloy that provides no loss of magnetic field strength. MEAS offers a standard scale with the following parameters for development purpose:

Symbol	Parameter	Condition	Min.	Typ.	Max.	Unit
L <sub>T</sub>	Length	MEAS magnetic scale only		1		m
L <sub>P</sub>	Pole length	MEAS magnetic scale only		5		mm
W	Width	MEAS magnetic scale only		10		mm
T	Thickness	MEAS magnetic scale only		1.3		mm
Δp	Accuracy	MEAS magnetic scale only		40		μm/m
T <sub>op</sub>	Operating temperature	MEAS magnetic scale only	-40		100	°C

**Table 17b:** Typical MEAS magnet-scale specification

The correct magnet dimensions and assembly geometry depend on the specific arrangement of the application and are part of the specification of the entire system.

# KMA36 universal magnetic encoder

## PACKAGE DRAWING

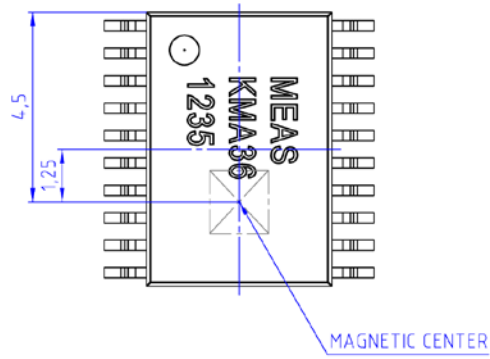

**Figure 7:** Package drawing (Magnetic center)

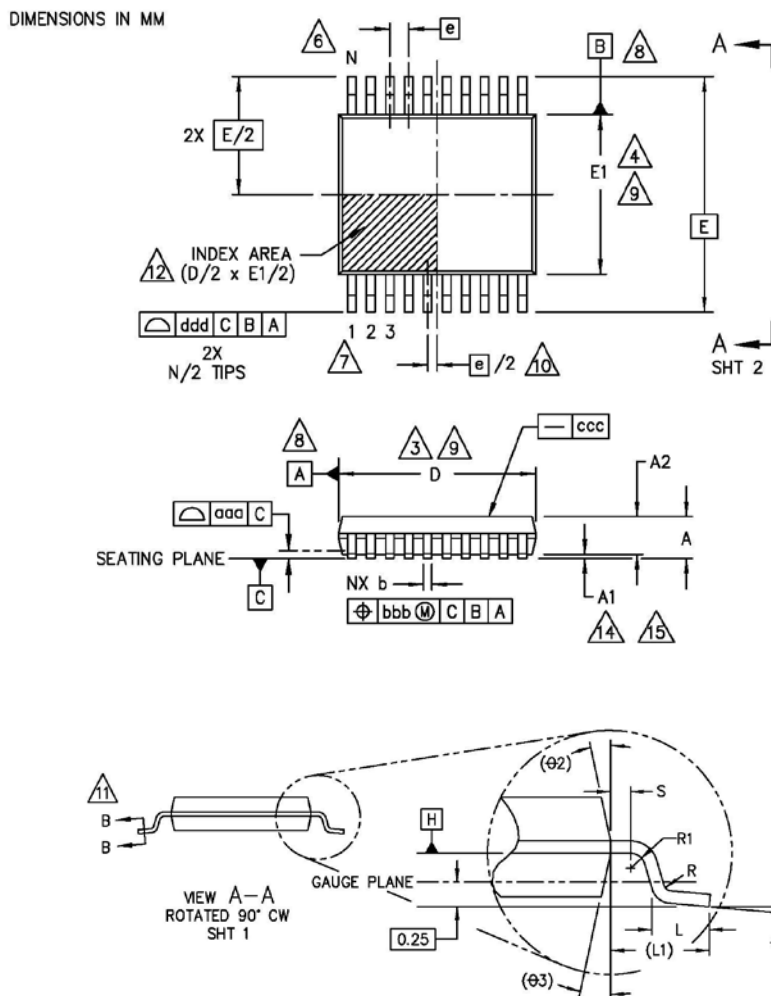

**Figure 8:** Package drawing

# KMA36 universal magnetic encoder

COMMON DIMENSIONS (MILLIMETERS)			
Symbol	Min.	Typ.	Max.
A	-	-	1.20
A1	0.05	-	0.15
A2	0.80	1.00	1.05
b	0.19	-	0.30
D	6.40	6.50	6.60
E	-	6.40	-
E1	4.30	4.40	4.50
e	-	0.65	-
L	0.45	0.60	0.75
N	-	20	-
R	0.09	-	-
S	0.20	-	-

**Table 18:** common dimensions

# KMA36 universal magnetic encoder

---

## ORDERING CODE

---

Product	Description	Article number
KMA36	KMA36 TSSOP20	G-MRMO-031

**Table 19:** Ordering codes

This data sheet contains data from the preliminary specification. Supplementary data will be published later. Measurement Specialties reserves the right to change the specification without notice, in order to improve the design and performance of the product.

## 联系方式

---



**深圳市亿为测控电子有限公司**  
Shenzhen Bill-Well Measurement & Control Electronics Co., Ltd.

广东省深圳市南山区创业路怡海广场东座2407 邮编：518000

电话：+86 755 2641 9890 传真：+86 755 2641 9680

电子邮箱：sales@bill-well.com