

Detector Assembly EPM-4001

Silicon Photodiode
Lead Frame Construction
Pulse Oximetry Component

The EPM-4001 Detector Assembly uses a silicon planar diffused photodiode specially designed for medical applications. It features high efficiency and fast response. The EPM-4001 Detector Assembly is spectrally matched to emitter assemblies ELM-4001 and ELM-4002.

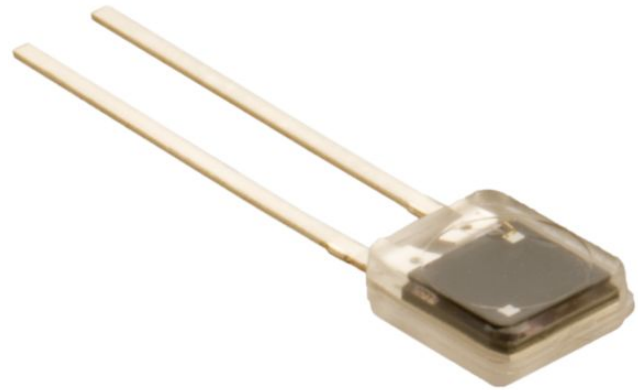

FEATURES

- Low Cost
- Lead Frame Construction
- Fast Response
- Matched to 660nm Emitters
- High Efficiency
- Clear Epoxy Lens
- Compact Package
- Active Area: 8mm²

APPLICATIONS

- Pulse Oximetry
- Finger/Ear Probes
- Disposable Strip or Butterfly Sensors

Dimensions

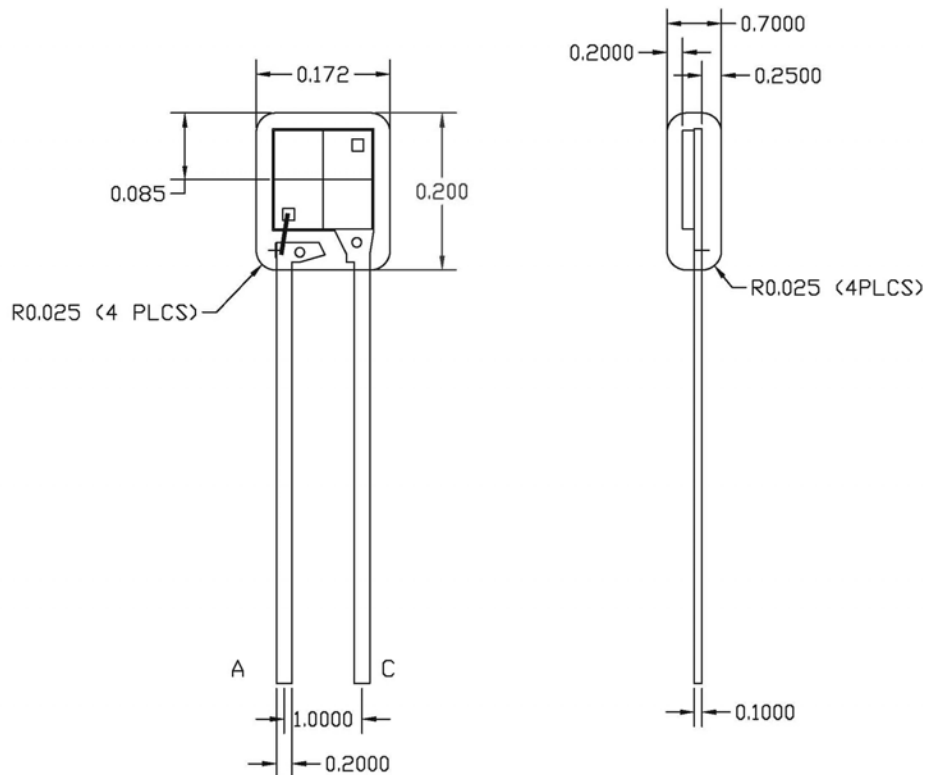

Detector Assembly EPM-4001

Specifications & Ratings

Parameter @ 25°C	Symbol	Conditions	Min.	Typ.	Max.	Absolute	Unit
Power Dissipation	P_d					150	mW
Operating Temperature	T_{opr}					-55~+70	°C
Storage Temperature	T_{stg}					-55~+70	°C
Soldering Temperature	T_{sol}					260	°C
Forward Voltage	V_f	$I_f=100\mu A$		50			V
Reverse Voltage	V_r	$I_r=100\mu A$			0.70		V
Shunt Resistance	R_{sh}	$\pm 10mV$	40				mΩ
Capacitance	C_t	$V_r=0V$			70		pF
Spectral Sensitivity	λ		400		1080		nm
Rise Time/Fall Time	T_r/T_f	$V_r=0V, R_l=50\Omega$			350		nSec
Responsivity	R	$\lambda = 540nm$	0.28				A / W
Temp. Coef. Of Isc	β_t				0.18		%

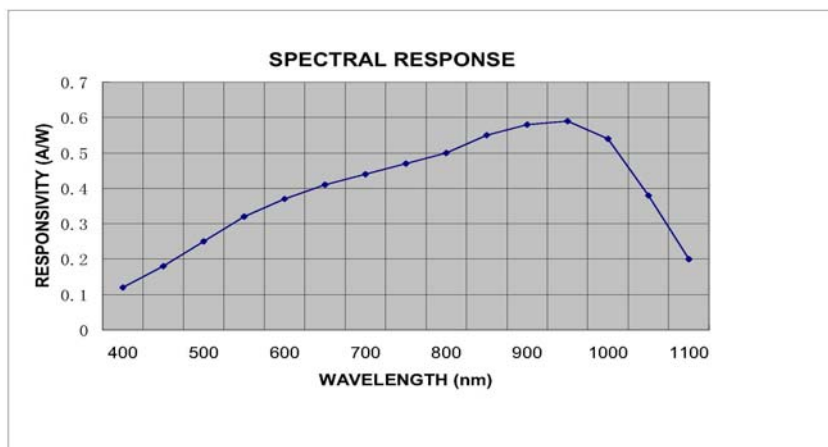

联系方式



深圳市亿为测控电子有限公司
Shenzhen Bill-Well Measurement & Control Electronics Co., Ltd.

广东省深圳市南山区创业路怡海广场东座2407 邮编：518000

电话：+86 755 2641 9890 传真：+86 755 2641 9680

电子邮箱：sales@bill-well.com