

Detector Assembly EPM-2001

Silicon Photodiode Ceramic Substrate Oximetry Component

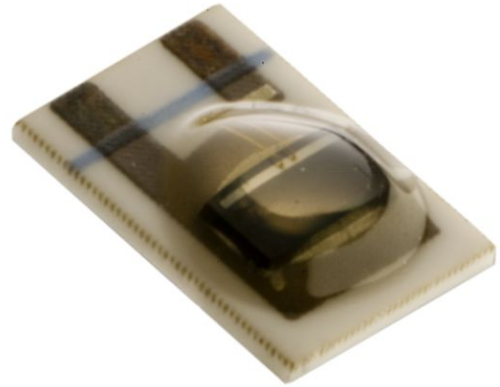

The **EPM-2001 Detector Assembly** uses a silicon planar diffused photodiode specially designed for medical applications. It features high efficiency and fast response. The EPM-2001 Detector Assembly is spectrally matched to Emitter Assemblies ELM-3001, ELM-3002, ELM-3003, and ELM-3004.

FEATURES

- Fast Response
- Matched to 660nm Emitters
- High Efficiency
- Ceramic Substrate
- Active Area: 8mm²
- Compact 5mm x 7mm Package

APPLICATIONS

- Pulse Oximetry
- Finger/Ear Probes
- Soft Silicone Sensors

Dimensions

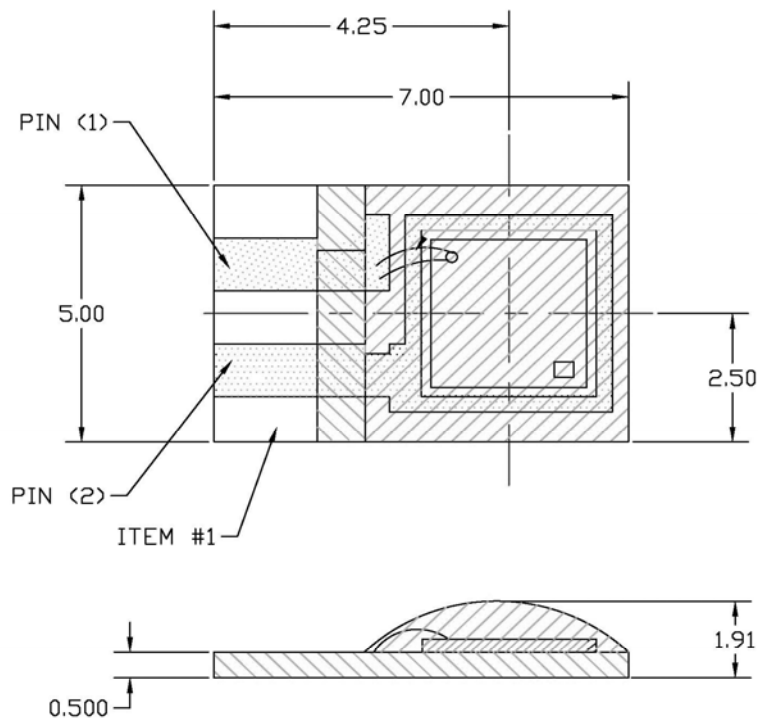

ACTIVE AREA: 8.07 mm²
CHIP SIZE: 3.175mm X 3.175mm
PACKAGE SIZE: 5mm X 7mm

Detector Assembly EPM-2001

Specifications & Ratings

Parameter @ 25°C	Symbol	Conditions	Min.	Typ.	Max.	Absolute	Unit
Power Dissipation	P_d					150	mW
Operating Temperature	T_{opr}					-55~+70	°C
Storage Temperature	T_{stg}					-55~+70	°C
Soldering Temperature	T_{sol}					260	°C
Forward Voltage	V_f	$I_r=100\mu A$		50			V
Reverse Voltage	V_r	$I_r=100\mu A$			0.70		V
Shunt Resistance	R_{sh}	$\pm 10mV$	40				mΩ
Capacitance	C_t	$V_r=0V$			70		pF
Spectral Sensitivity	λ		400		1080		nm
Rise Time/Fall Time	T_r/T_f	$V_r=0V, R_l=50\Omega$			350		nSec
Responsivity	R	$\lambda = 540nm$	0.28				A / W
Temp. Coef. Of Isc	β_t				0.18		%

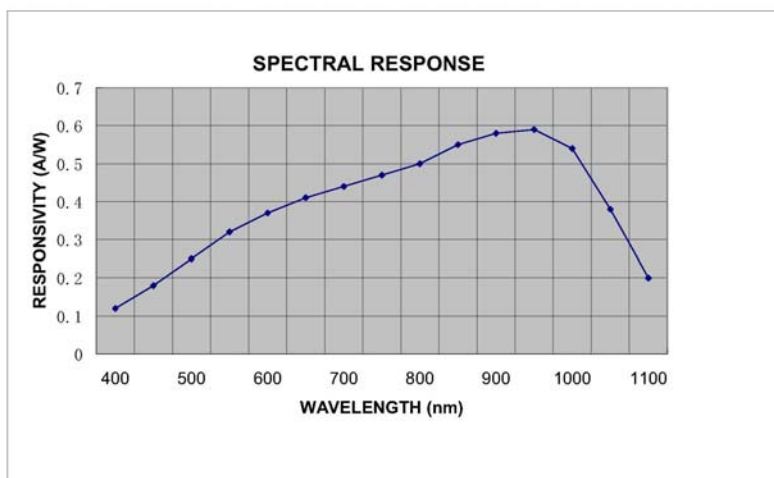

The information in this sheet has been carefully reviewed and is believed to be accurate; however, no responsibility is assumed for inaccuracies. Furthermore, this information does not convey to the purchaser of such devices any license under the patent rights to the manufacturer. Measurement Specialties, Inc. reserves the right to make changes without further notice to any product herein. Measurement Specialties, Inc. makes no warranty, representation or guarantee regarding the suitability of its product for any particular purpose, nor does Measurement Specialties, Inc. assume any liability arising out of the application or use of any product or circuit and specifically disclaims any and all liability, including without limitation consequential or incidental damages. Typical parameters can and do vary in different applications. All operating parameters must be validated for each customer application by customer's technical experts. Measurement Specialties, Inc. does not convey any license under its patent rights nor the rights of others.

Ordering information

Description

Detector Assembly; Ceramic; 8mm²

Part Number

EPM-2001

联系方式



深圳市亿为测控电子有限公司
Shenzhen Bill-Well Measurement & Control Electronics Co., Ltd.

广东省深圳市南山区创业路怡海广场东座2407 邮编：518000

电话：+86 755 2641 9890 传真：+86 755 2641 9680

电子邮箱：sales@bill-well.com