

MRLF30-USB Linear Absolute Sensor

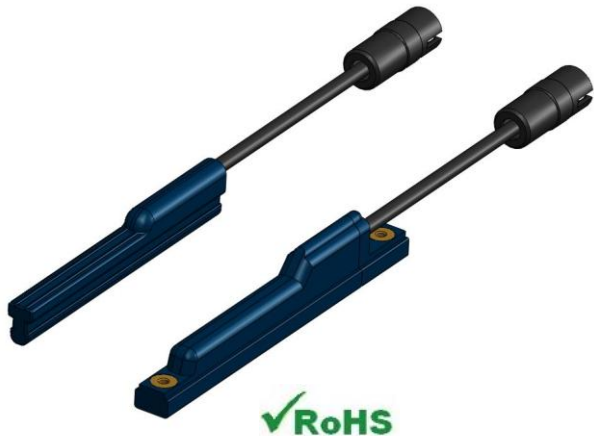

- Magneto resistive sensors array
- Linear absolute sensor
- High accuracy
- Excellent repeatability
- Very small housing
- C-Slot compatible
- Full duplex serial interface
- USB power supply

DESCRIPTION

Due to its featured properties - high accuracy and very low hysteresis - with a very small housing compatible with standard C-Slot and T-Slot cylinder, MRLF30 is providing great functional reliability and precise measurement for industrial environment, handling machine and machine tools.

By using the well established **Anisotropic Magneto Resistive** technology and a combination of multiple magneto resistive sensors within an array construction, MRLF30 is able to determine with good accuracy and very low hysteresis the position of an external magnet.

MRLF30-USB is a demonstrator device which is ready to use. The full duplex serial interface and a USB power supply make the interaction between the user and the sensor system easy.

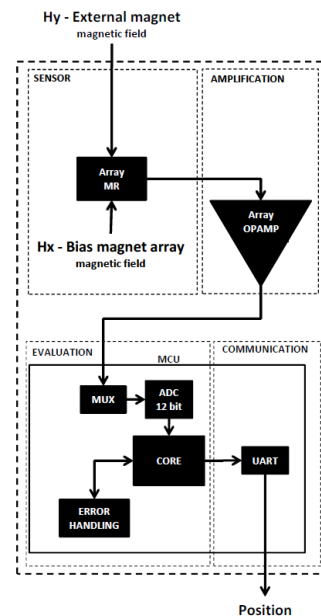

Figure 1: Functional block description

FEATURES

- Contactless absolute linear measurement
- High accuracy
- Very low hysteresis
- Very small housing
- C-Slot compatible
- Magnet out of range detection
- Full duplex serial interface
- Easy try and use
- RoHS compliant

APPLICATIONS

- Industrial environment
- Handling machine
- Machine tools
- Pneumatic cylinder positioning
- Gripper positioning

MRLF30-USB Linear Absolute Sensor

MECHANICAL DIMENSIONS

Two housing are available for MRLF30-USB; one is compatible with C-Slot standard and one is compatible with T-Slot standard.

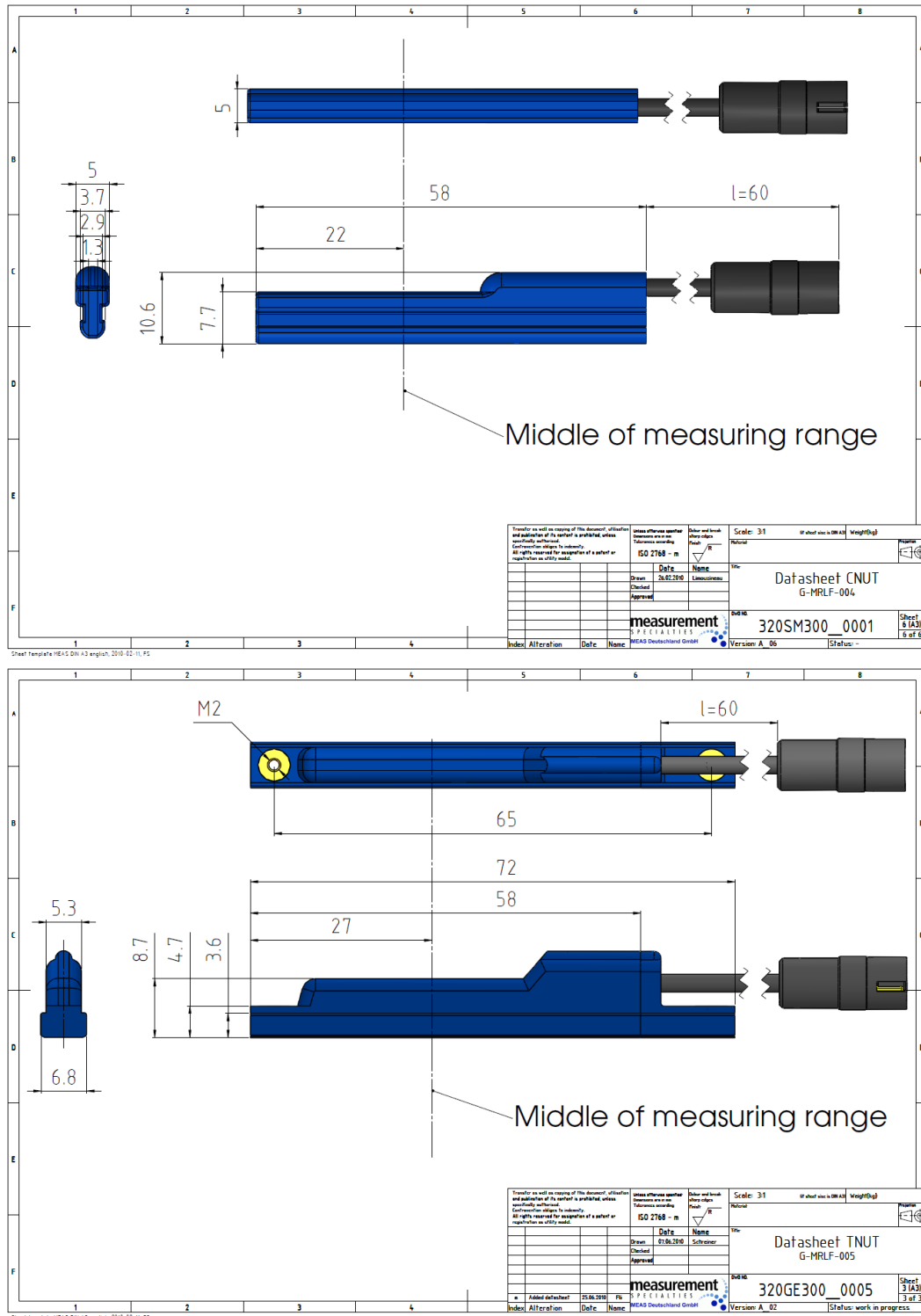

MRLF30-USB Linear Absolute Sensor

ABSOLUTE MAXIMUM RATINGS

Symbol	Parameter	Condition	Min.	Typ.	Max.	Unit
V _{cc}	Operating voltage		4		6	V

Table 1: Absolute maximum ratings

ELECTRICAL CHARACTERISTICS

Symbol	Parameter	Condition	Min.	Typ.	Max.	Unit
V _{cc}	Operating voltage		4.5		5.5	V
S _L	Linear domain		- 15		+ 15	mm
Δ _R	Repeatability error*			±0.05	± 0.15	mm
Δ _L	Linearity error*			± 0.2	± 0.6	mm
t _{upd}	Update time			10		ms
I _{cc}	Power consumption			32	40	mA

Table 2: Electrical characteristics

* Repeatability and linearity errors are defined for many types of magnets

MAGNET

MRLF30 is delivered with a standard firmware which allows doing measurement only with a Type B magnet. The specification of the Type B magnet is given in the following table.

Symbol	Parameter	Condition	Min.	Typ.	Max.	Unit
F	Form			Disc		
∅	Diameter			6		mm
T	Thickness			2		mm
M _{dir}	Magnetization direction			Axial		
M _{mat}	Material	N38H		NdFeB		
M _{coa}	Coating			Ni - Cu - Ni		

Table 3: Type B magnet specification

An enhanced firmware is available and gives the user more universal performance. The advanced firmware can be used with a wide range of magnet types, sizes and forms. MEAS Deutschland GmbH has developed its own software to determine whether the user magnet is compatible or not with MRLF30. To use the MRLF30 with a customer specific magnet only a single calibration is required when the system is mounted.

INTERFACE

The user can communicate through a serial bus with MRLF30-USB using a standard USB Type A port and the adapter cable delivered with the demonstrator. Please refer to **MR_FTDI_USB_COM_ApplicationNote** for more information.

MRLF30-USB Linear Absolute Sensor

The following settings need to be used for the virtual COM port.

Parameter	Value	Unit
Protocol	RS232	
Baud rate	38.4	kb/s
Data bits	8	bits
Stop bits	0	bits
Parity	disabled	
Flow control	disabled	
Maximum polling rate	10	ms

Table 4: Serial communication settings

The following protocol needs to be used to retrieve data.

The command **v** gives the serial number of the part:

```
Prompt>> v
B7007_F8008_GMRLF0051009D0026
```

The command **p** gives the position:

```
Prompt>> p
POSITION +114688
```

Each data string is followed by **CR** [0x0D] and **LF** [0x0A] characters. The position can be converted in millimeters using the following formula. If the position is equal to ± 999999 , it means MRLF30 was not able to determine a valid position. It is usually the consequence of an incorrect placement of the magnet, or incompatible magnet, or out of range position.

$$P_{mm} = \frac{P_{RS232}}{16384}$$

Formula 1: Position conversion in millimeters

DEMONSTRATION SOFTWARE

After plugging **MRLF30-USB** and configuring the virtual COM port, it is possible to check if the demonstrator is working properly by using the demonstration software.

Start the application **MRLF30_Demo_CNUT.exe** or **MRLF30_Demo_TNUT.exe** depending on which demonstrator you are using. When pressing on the red connecting button, the application will try to communicate through the virtual serial COM port with the measurement system. If the communication is successful the blue button will indicate that the application is connected, as well as the console.

If the magnet is in range, and if the position is within the maximal stroke length limit, the position will be indicated on the scale with a black arrow. To exit the program, and stop the communication, press again the blue button or close the window.

MRLF30-USB Linear Absolute Sensor

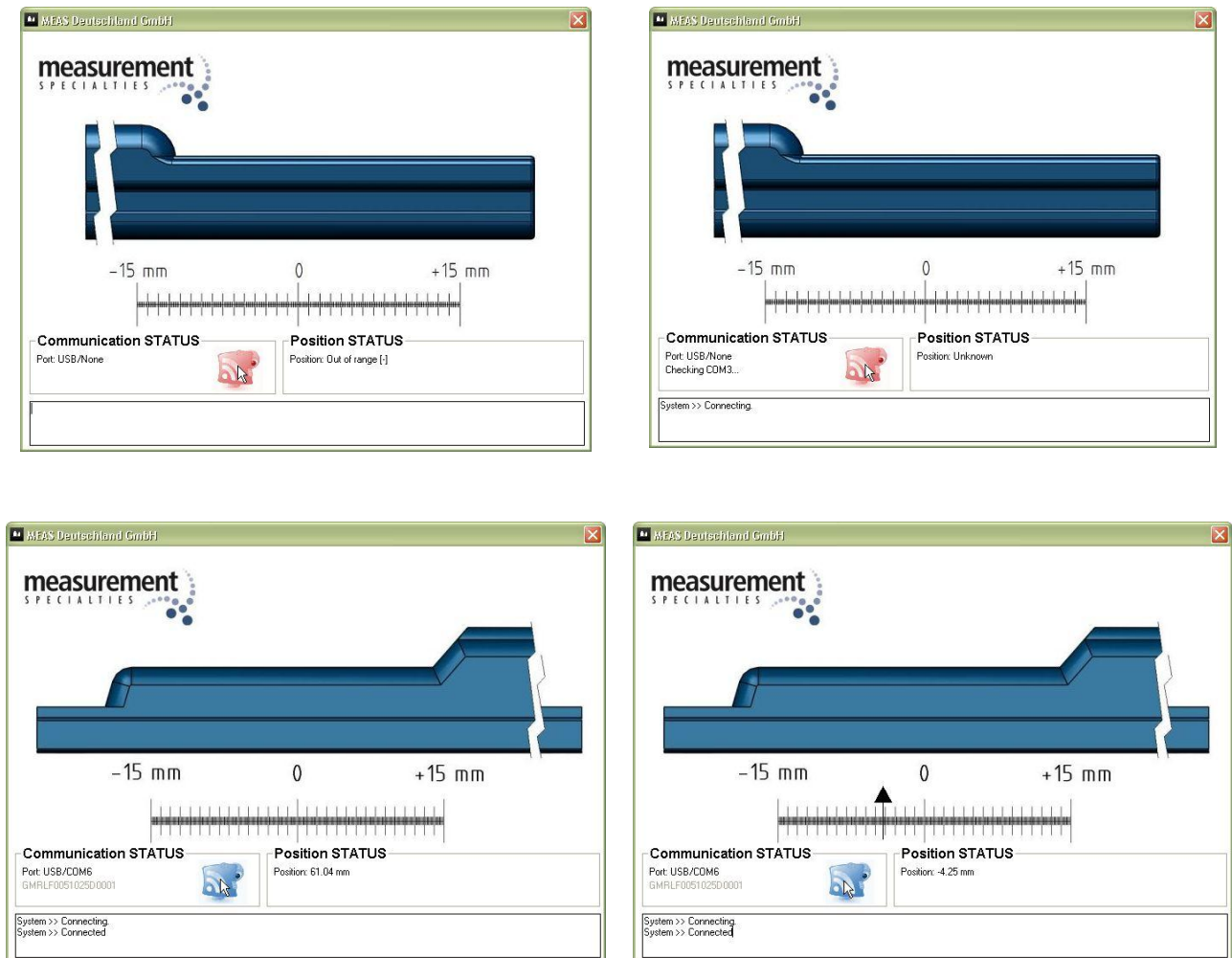

Figure 3: MRLF30-USB_Demo (CNUT and TNUT)

联系方式



深圳市亿为测控电子有限公司
Shenzhen Bill-Well Measurement & Control Electronics Co., Ltd.

广东省深圳市南山区创业路怡海广场东座2407 邮编：518000

电话：+86 755 2641 9890 传真：+86 755 2641 9680

电子邮箱：sales@bill-well.com