

# MODEL ED32i TTL LINEAR ENCODER



**Reliable non-contact measurement**

**Can be used for rotary as well as linear measurements**

**Differential 5V TTL A/B-Quadrature output**

**Error detection like out of range or missing scale**

**Programmable reference mode and position**

- **Field programmable resolution**

## DESCRIPTION

The ED32i is a linear incremental encoder based on the well established magnetoresistive sensor technology. The contactless magnetic measuring principle is used for precise incremental displacement measurement by utilizing a magnetized scale with alternating north and south poles. Air gaps up to 2mm are possible between scale and the read head. The encoder device is equipped with an internal sine / cosine interpolation unit that transforms the input signals directly into A/B-quadrature output signals. The special arrangement of the used AMR sensors allows a resolution in the area of a few micrometers in combination with high travel speeds. An integrated magnetic sensor detects magnetic reference marks. Optional adaptor plates solve special mounting needs for customer specific applications easily.

A special feature of the ED32i is the possibility of parameter programming with or firmware updates, even after field installation.

## FEATURES

- **Precise contactless incremental measurement**
- **Accuracy: +/-1 increment**
- **Resolution:  $\geq 10\mu\text{m}$**
- **Differential 5V TTL A/B-quadrature output**
- **Lost scale/magnet recognition**
- **Programmable reference modus**
- **Programmable resolution (continuously)**
- **Firmware update possible**
- **2 status LEDs**
- **Customized adaptor-plate for easy assembly**

## APPLICATIONS

- **Measurement of positions, movements, velocities**
- **Angular measurement utilizing pole wheels**
- **Position measurement in harsh environments**
- **XYZ Tables**
- **Linear & cross stages**

# MODEL ED32i TTL LINEAR ENCODER

## ABSOLUTE MAXIMUM RATINGS

Absolute maximum ratings are limiting values of permitted operation and should never be exceeded under the worst possible conditions either initially or consequently. If exceeded by even the smallest amount, instantaneous catastrophic failure can occur. And even if the device continues to operate satisfactorily, its life may be considerably shortened.

PARAMETER	SYMBOL	CONDITIONS	MIN	TYP	MAX	UNIT
Supply Voltage	Vcc	Measured versus GND	-0.3		5.5	V
Operating Temperature	Top		-25		85	°C
Storage temperature	Tstor		-40		85	°C

Stress above one or more of the limiting values may cause permanent damage to the device. Exposure to limiting values for extended periods may affect device reliability.

## OPERATING CONDITIONS

If not otherwise noted, 25°C ambient temperature, 5V supply voltage applied.

Parameter	Symbol	Conditions	Min	Typ	Max	Unit
Supply voltage	Vcc	Measured versus GND		5		V
Supply Current	I	Full ambient temp. range, no output load		60		mA
Digital Output Clock Rate (A/B)	A,A,B,B		20		100	kHz

## TYPICAL PERFORMANCE CURVE

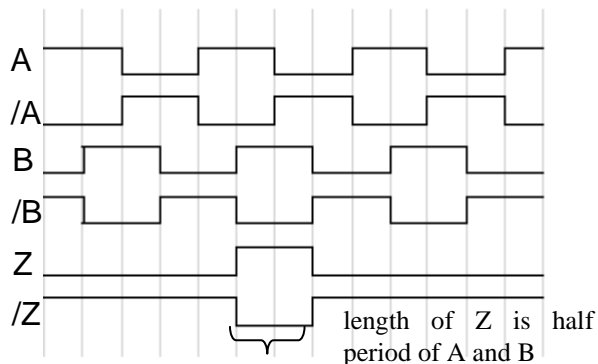

- channel A and B are phase shifted for 90°
- index channel Z could be placed at every position
- length of channel Z could be quarter and half period of signal A and B

# MODEL ED32i TTL LINEAR ENCODER

## MECHANICAL DIMENSIONS

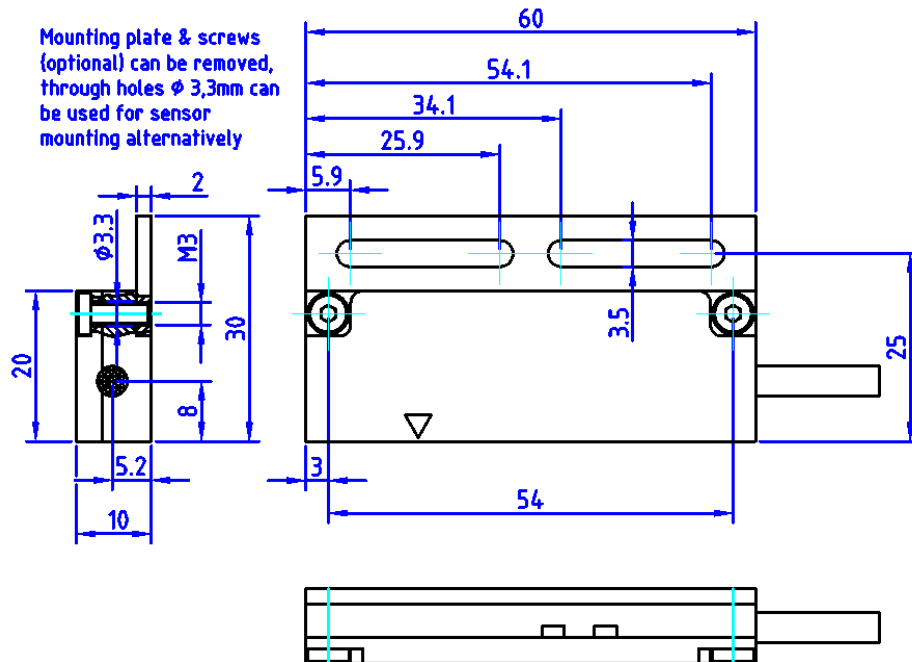
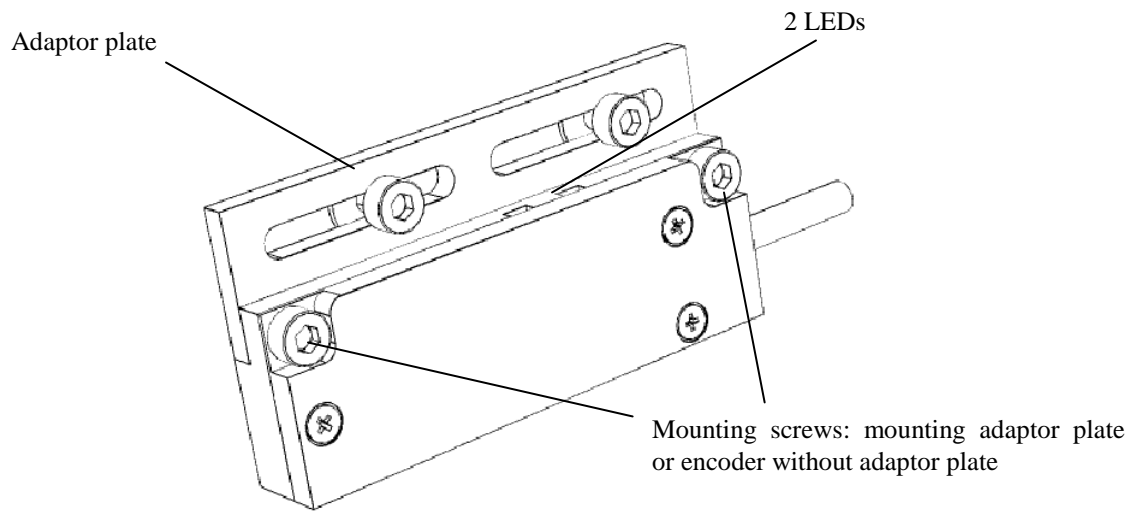

# MODEL ED32i TTL LINEAR ENCODER

## CONNECTORS (OPTIONAL)

Name	Description	Color: Cable end open (Standard)	D-SUB 9 pin no.
/A	Channel A - inverted	grey	5
GND	Ground	yellow	4
/B	Channel B - inverted	green	3
ERROR	Error Signalisation	red	2
/Z	Reference Channel - inverted	orange	1
A	Channel A	blue	9
+5V	Supply Voltage	violet	8
B	Channel B	brown	7
Z	Reference Channel	black	6
PE/Earth	Screen	Shield	Shield

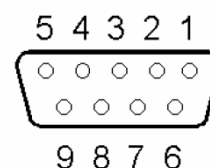

## PERFORMANCE SPECS

Parameter	Condition	Symbol	Min	Typ	Max	Unit
Operating Voltage		V <sub>CC</sub>		<b>5</b>		V
Resolution				<b>10 (*)</b>		µm
System accuracy	+/- 1 Increment			<b>+/- 20 (*)</b>		µm
Pole pitch		d <sub>N-S</sub>		<b>5</b>		mm
Gap sensor / magnetic stripe			<b>0.1</b>	<b>1.0</b>	<b>2.0</b>	mm
Velocity		V	<b>0</b>		<b>4(**)</b>	m/s
Max. Output Freq./Channel	resolution: 10µm	f <sub>out</sub>			<b>100</b>	kHz
Output circuit	Quad 5V RS485					
Output signals	A, /A, B, /B, Z, /Z		<b>0</b>		<b>5</b>	V
Operating Temperature		T <sub>OP</sub>	<b>-40</b>		<b>+85</b>	°C
Storage Temperature			<b>-55</b>		<b>+85</b>	°C
Cable length	cable end open			<b>2.0</b>		m
Dimension	L x B x H			<b>60 x 10 x 20</b>		mm

\* Parameters like resolution can be set within the ED32i with an external device, see section 'Parameter Programming'.

\*\* Depends on programmed resolution.

# MODEL ED32i TTL LINEAR ENCODER

## ENCODER TO SCALE MOUNTING

The ED32i encoder need to be adjusted within the given mechanical tolerances of the figure mentioned below. In order to read accurately, the tilt should not exceed  $\pm 1^\circ$ . The magnetic scale has a steel-band on the back that gives mechanical stability and avoids temperature based expansion. The air gap between encoder and scale could be 2.00 mm in maximum.

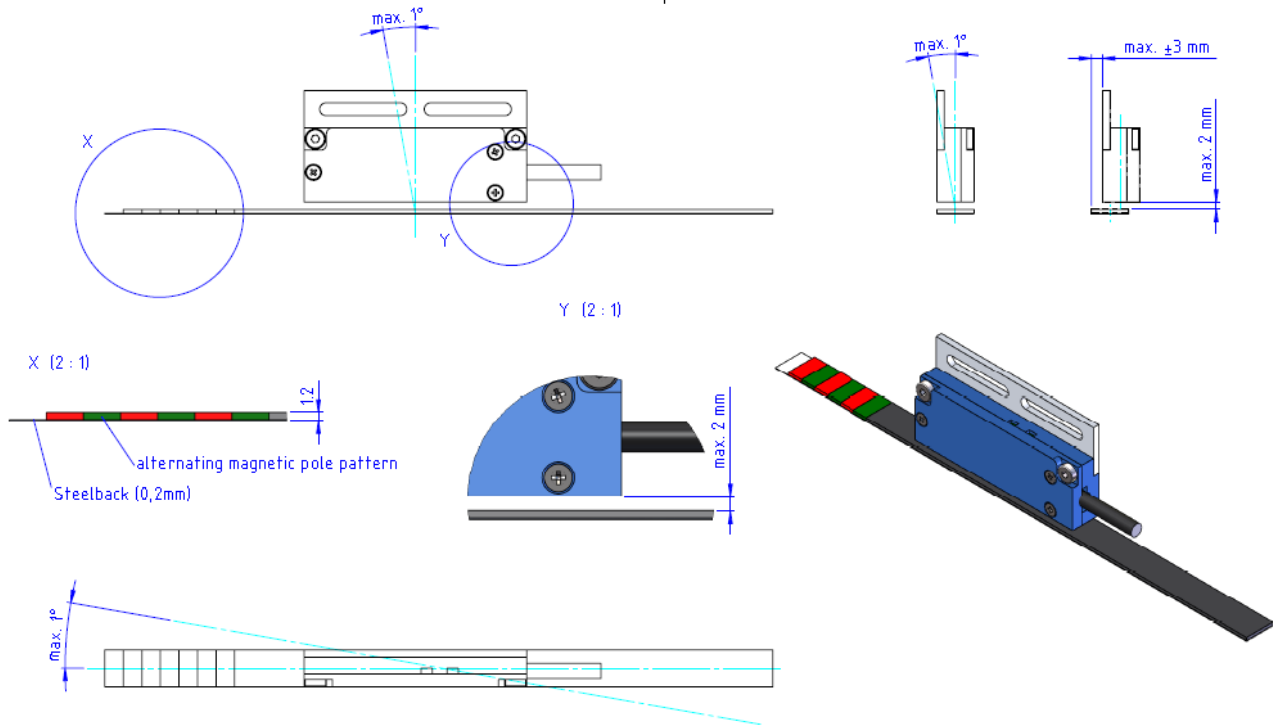

## PARAMETER PROGRAMMING

The ED32i can be parameterized via a programming device. Parameters that can be set are:

<b>Resolution:</b>	1 $\mu$ m ... 5mm continuously
<b>Reference Mode:</b>	none, periodic at Reference Position, once at Reference Position
<b>Reference Position:</b>	Reference Position within 5mm, combined with external Reference Mark
<b>Reference Pulse Length:</b>	half or quarter length of A, B period
<b>Amplitude Borders:</b>	A_min and A_max for operating window
<b>Measurement Visualisation:</b>	1 Step - 0.5 * Resolution, blinking frequency of green LED

For further information on tailored parameters please contact *Measurement Specialities*.

# MODEL ED32i TTL LINEAR ENCODER

## DIGITAL INTERFACE

ED32i is available as standard quadrature output. Using an external programming device ED32i could work over an USART interface in digital mode which means that several commands as position feedback and parameterization are possible.

Another option is to use ED32i as USB device which offers the same digital interface. For this no additional programming device is necessary, the ED32i is handled and powered over the standard PC USB-interface.

Connecting ED32i as digital device:

ED32i\_TTL:

1. Plug in the ED32 in the programming device.
2. Start the ED32 Programming Application.
3. Choose ED32i in persistent Digital Mode.

--> The ED32i is now always starting in digital Mode and it's possible to use the listed commands to establish a measurement, calibration or parameter updates.

--> To reset the ED32i\_TTL to normal ABZ-Quadrature Output use steps 1 and 2 and choose "Normal Mode" from the ED32 Programming Application.

ED32i\_USB:

1. Plug in the ED32i\_USB to a USB-Port of the PC.

--> The ED32i\_USB is always starting in digital Mode and it's possible to use the listed commands to establish a measurement, calibration or parameter updates.

Commands (each Command has to be ended with an additional CR = "0x0D"):

Number	Command	Description
1	">"	ED32i returns an 24 character hexadecimal string + CR comprising 3 sets of 8 character hexadecimal strings where: First 8 characters are hex representation of count value (signed 32 bit) Next 8 characters are hex representation of count where reference/index was last seen (signed 32 bit) Final 8 characters are hex representation of status value e.g: 0000d54000000200000001+CR  position   ref       status   CR
2	"?"	ED32i returns 3 decimal values (not fixed width) separated by colons and terminated with CR in the form: nnnn:rrrr:ssss + CR where nnnn = encoder count rrrr = count value when reference/index last seen ssss = status e.g. 3412:2596:1 + CR (status value of 1 shows that a reference was detected—use 'b' to clear)
3	"z"	ED32i sets current count value to zero by applying an offset internally
4	"v"	ED32i returns software version +CR, e.g. "ED32_V1.0.3_100810"
5	"0"	ED32i stops auto transmission

# MODEL ED32i TTL LINEAR ENCODER

Number	Command	Description
6	"1"	ED32i starts auto transmission in hexadecimal modus lie ">"
7	"2"	ED32i starts auto transmission in decimal modus lie "?"
8	"ca"	ED32i starts auto calibration
9	"d"	ED32i displays persistent parameters in ASCII
10	"p..."	<p>ED32i programs a new set of parameters to its persistent EEPROM            e.g. pxxxx_xxxx_xxxx_xxxx_xxxx_xxxx_xxxx_xxxx + CR             A  B  C  D  E  F  G  H  CR            x stands for a numerical number from 0...9            _ stands for a blank            p is the initialising command</p> <p>A = Resolution in divisors of used pole with (PW) (e.g. PW = 5mm, A= 1000, Resolution of the system is 5µm)            B = Hysteresis in Resolution Steps (e.g. PW = 5mm, A = 1000, B = 1, Hysteresis is 5µm)            C = Max. Amplitude            D = Min. Amplitude            E = ReferenceModus (0= no Reference, 1 = multiple Reference, 2 = Single Reference)*            F = Offset Modus (0 = no adaptive Correction, 1 = with adaptive Correction)**            G = Reference Length Modus***            H = Reference Position in Steps within one Pole length</p>

\* , \*\* , \*\*\* = not yet implemented

PC-Application implementing the shown commands for ED32 with USB-Interface or ED32\_TTL via Programming Unit:

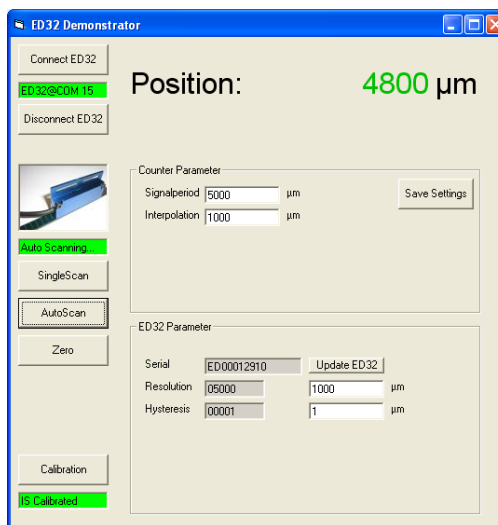

# MODEL ED32i TTL LINEAR ENCODER

## INSTALLATION

Mount the ED32i as shown in the following figure:

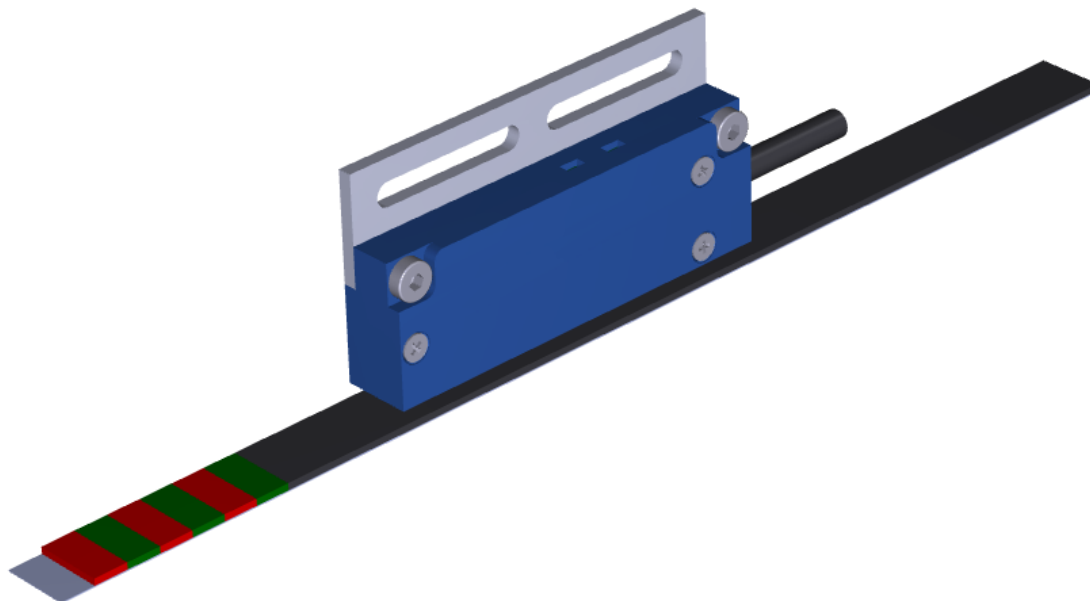

After power on, both LEDs (red and green) should be on. When the red LED goes off, the encoder is in measurement mode. Every millimeter the green LED toggles to give a visual feedback of the measurement. The red LED depicts a missing magnet function, which means the scale is too far away from the encoder or wrong mounted.

Step	LED red Status	LED green Status	Description
Power on	On	On	ED32i startup mode
ED32i without scale, wrong mounted	On	Off	ED32i too far away from scale / wrong mounting
Measurement (ED32i correct mounted over scale)	Off	On/Off	green LED visualizes measurement step (act. 1mm, programmable)



# MODEL ED32i TTL LINEAR ENCODER

---

## ORDERING CODES

---

Article number                      **G-MRED-100**

### 联系方式

---



**深圳市亿为测控电子有限公司**  
Shenzhen Bill-Well Measurement & Control Electronics Co., Ltd.

广东省深圳市南山区创业路怡海广场东座2407 邮编：518000

电话：+86 755 2641 9890      传真：+86 755 2641 9680

电子邮箱：sales@bill-well.com